

Bakar: staklo iz rimske nekropole

Gregl, Zoran; Lazar, Irena

Authored book / Autorska knjiga

Publication status / Verzija rada: **Published version / Objavljena verzija rada (izdavačev PDF)**

Publication year / Godina izdavanja: **2008**

Permanent link / Trajna poveznica: <https://um.nsk.hr/um:nbn:hr:300:641656>

Rights / Prava: [In copyright](#)/[Zaštićeno autorskim pravom.](#)

Download date / Datum preuzimanja: **2024-10-14**



Repository / Repozitorij:

[AMZdepo - Repository of the Archaeological Museum in Zagreb](#)





Zoran Gregl
Irena Lazar

BAKAR

Staklo iz rimske nekropole

The Glass from the Roman Cemetery

Musei Archaeologici
Zagrabiensis Catalogi
et Monographiae

Vol.

*Musei Archaeologici Zagrabensis Catalogi et Monographiae
Katalozi i monografije Arheološkoga muzeja u Zagrebu*

Vol. V | Sv. V

Zoran Gregl & Irena Lazar

BAKAR

Staklo iz rimske nekropole
The Glass from the Roman Cemetery

Arheološki muzej u Zagrebu, 2008.

**Musei Archaeologici Zagrabienis
Catalogi et Monographiae**

Katalozi i monografije Arheološkoga
muzeja u Zagrebu
Svezak V

Zoran Gregl & Irena Lazar

Bakar – Staklo iz rimske nekropole

Nakladnik:

Arheološki muzej u Zagrebu

Za nakladnika:

Ante Rendić-Miočević

Sunakladnik:

**Inštitut za dediščino Sredozemlja, Znanstveno raziskovalno
središče Koper, Univerza na Primorskem**

Urednica:

Vesna Herak

Recenzenti:

Branka Migotti

Mitja Guštin

Prijevod sa slovenskog na hrvatski jezik:

Zdravka Hincak

Lektura:

Isaac Salih

Prijevod na engleski jezik:

Barbara Smith-Demo

Crteži:

Andreja Izlakar

Miljenka Galić, T 5:3, T 8:1.

Fotografije:

Igor Krajcar

Restauracija materijala:

Zrinka Znidarčić

Realizacija:

LASERplus d.o.o.

Naklada 700 primjeraka

**Musei Archaeologici Zagrabienis
Catalogi et Monographiae**

Catalogues and Monographs of the Archaeological
Museum in Zagreb
Volume V

Zoran Gregl & Irena Lazar

Bakar – The Glass from the Roman Cemetery

Publisher:

Archaeological Museum in Zagreb

For the publisher:

Ante Rendić-Miočević

Co-publisher:

**Institute for Mediterranean Heritage, Science and Research
Centre Koper, University of Primorska**

Editor:

Vesna Herak

Reviewers:

Branka Migotti

Mitja Guštin

Translation from Slovene to Croatian:

Zdravka Hincak

Croatian proof reading:

Isaac Salih

English translation:

Barbara Smith-Demo

Drawings:

Andreja Izlakar

Miljenka Galić, T 5:3, T 8:1.

Photographs:

Igor Krajcar

Glass conservation and restoration:

Zrinka Znidarčić

Realisation:

LASERplus d.o.o.

Printed in 700 copies



ARHEOLOŠKI MUZEJ U ZAGREBU

Zoran Gregl & Irena Lazar

BAKAR
Staklo iz rimske nekropole
The Glass from the Roman Cemetery

Sadržaj / Contents

Predgovor / Foreword	7
Zoran Gregl	
Rimska nekropola Bakar / The Roman Cemetery of Bakar.	11
Šime Ljubić	
Arheologičko izkapanje u Bakru – Reprint.	21
Irena Lazar	
Staklo iz rimske nekropole u Bakru / The Glass from the Roman Cemetery in Bakar ..	49
Stolno posuđe / Tableware	51
Posuđe za pohranu / Storage vessels	66
Kozmetičko posuđe / Vessels for cosmetics and medicinal unguents	81
Zaključna zapažanja / Final observations.	92
Popis literature / Bibliography.	97
Irena Lazar, Marina Gregl, Zoran Gregl	
Katalog predmeta / Catalogue of Objects	101
Table / Plates.	155

Predgovor

Zahvaljujući doista nesvakidašnjem spletu okolnosti zagrebački Arheološki muzej u rijetkoj je prigodi: nakladničku aktivnost, koja je posljednjih godina znatno intenzivirana, u 2008. god. trebao bi okruniti objavljivanjem čak nekoliko svezaka u seriji Katalozi i monografije Arheološkog muzeja u Zagrebu (*Musei Archaeologici Zagrabienensis Catalogi et Monographiae*), koja je odmah nakon pokretanja naišla na veliko zanimanje u stručnim arheološkim krugovima. Nije teško zaključiti da je živahnoj aktualnoj produkciji djelomice pridonio zastoj do kojega je iz različitih razloga došlo u odnosu na planirani ritam pojavljivanja svezaka u toj za Muzej sve važnijoj i sve potrebnijoj seriji. Navedena konstatacija ne odnosi se, međutim, na aktualni, 5. svezak u toj tek nedavno pokrenutoj seriji muzejskih monografsko-kataloških izdanja, namijenjenih objavljivanju različitih tematski definiranih skupina spomeničkog materijala iz bogatog muzejskog fundusa. U ovom svesku obrađen je stakleni materijal otkriven potkraj 19. st. tijekom istraživanja rimskodobne nekropole u Bakru. Svezak je pripremljen u skladu s planiranim programskim aktivnostima za 2008. god. te se nadamo da će biti tiskan na vrijeme, upravo onako kako je bilo i planirano.

Malo tko bi mogao zaniijekati neodoljivu privlačnost različitih predmeta načinjenih od stakla. Oni su nedvojbeno među najatraktivnijom spomeničkom građom mnogih muzejskih zbirki. Neovisno o kronološkim, zemljopisnim ili nekim drugim njihovim osobinama, predmeti načinjeni od stakla privlače pozornost velikog broja zainteresiranih stručnjaka, ali možda u još većoj mjeri sveukupne javnosti, koja je navikla susretati se s takvom vrstom građe u gotovo svim relevantnim stalnim izložbenim postavima, ili u sklopu različitih povremenih izložbenih događanja.

Mnogi koji su se bavili korijenima proizvodnje stakla naglašavaju podatak da je nju moguće uvrstiti među najstarije čovjekove inovativne stvaralačke dosege. Proizvodnja stakla rezultat je vrlo zahtjevnog tehnološkog procesa. Njega karakterizira korištenje odgovarajućih sirovina te primjena visokih temperatura, koje je bilo moguće ostvariti u odgovarajućim staklarskim pećima. I u današnje vrijeme često se spekulira o ishodištima staklarske proizvodnje, o najstarijim središtima iz kojih je pristizala pročišćena staklena pasta, a znatno kasnije i bezbojno ili prirodno obojeno prozirno staklo. Obično se u tom kontekstu spominju Egipat, Sirija i Mezopotamija, kao i neki drugi krajevi na Bliskom Istoku i Sredozemlju. O kasnijoj proizvodnji stakla, osobito onoj koja je potekla iz radionica u Rimu, izvješćuju,

Foreword

Thanks to a truly extraordinary series of circumstances, the Archaeological Museum is in an unusual position: its publishing activities, which have considerably intensified in the last few years, might well be crowned in 2008 with several volumes in the series Catalogues and Monographs of the Archaeological Museum in Zagreb (*Musei Archaeologici Zagrabienensis Catalogi et Monographiae*), which immediately after its commencement met with great interest in professional archaeological circles. It is not difficult to conclude that the lively current production was partially contributed to by a delay that occurred for various reasons in the planned rhythm of appearance of the volumes in this increasingly important and increasingly necessary series for the museum. The above, however, does not apply to the current, 5th volume, in this only recently launched series of museum monographs and catalogue publications, intended for the publication of various thematically defined groups of archaeological material from the rich collections of the museum. This volume deals with the glass material discovered at the end of the 19th century during excavation of a Roman cemetery in Bakar. This volume was prepared in accordance with the planned program of activities for 2008, and it is to be hoped that it will also be printed on schedule, just as had been planned.

There are few who would deny the irresistible attraction of various objects made of glass. They are undoubtedly among the most attractive artifacts and material in many museum collections. Independently of their chronological, geographic, or other characteristics, objects made of glass attract the attention of a great number of interested experts and, perhaps to an even greater extent, the public as a whole, who are used to coming across such material in almost all relevant permanent displays, or in the context of various temporary exhibition events.

Many who have studied the roots of glass manufacture emphasize the fact that it can be placed among the very earliest innovative creative achievements of mankind. The production of glass is a result of a very demanding technological process. This is characterized by the utilization of the appropriate raw materials and the application of high temperatures, which could be achieved in the corresponding glass furnaces. Even in the present day, speculation still exists about the origins of glass production and about the earliest centers from which refined glass paste arrived, and much later colorless or naturally colored transparent glass. Egypt, Syria, and Mesopotamia are usually mentioned in this context, as well as certain other regions in the Near East and Mediterranean. The later production of glass, particularly glass from workshops in Rome, is documented, for

primjerice, epigrafički, kao i neki literarni izvori, među kojima osobito treba istaknuti zapažanja Plinija Starijeg, Strabona i dr. Potrebno je imati u vidu činjenicu da se presudnim za masovnu proizvodnju stakla, prihvatljivu širokim slojevima društva, pokazao izum staklarske lule, a to se, po svemu sudeći, dogodilo tijekom 1. st. pr. Kr. Njezino korištenje omogućilo je puhanje stakla, što je bio značajan tehnološki iskorak u njegovoj proizvodnji i sve široj i raznolikijoj primjeni. Staklo je tim činom prestalo biti luksuznim materijalom dostupnim samo odabranim privilegiranim društvenim slojevima, već je postalo robom namijenjenom svakodnevnom korištenju, dostupnom gotovo svim slojevima stanovništva. U kasnijim razdobljima, uz izradu posuda za različite namjene, staklo je bilo u širokoj primjeni i u izradi nakita, kao i u sve popularnijoj gliptici. Krhkost i lomljivost svakako su bile njegove lošije osobine, ali su prednosti upotrebe staklenih proizvoda nadvladale nedostatke drugih materijala koji su upotrebljavani u slične svrhe. Osim vrline koje su praktične naravi, minimalne težine, prozirnosti te osobito neporoznosti, zbog čega sadržaj koji je bio pohranjen u staklenim posudama nije bio podložan promjenama mirisa ili okusa, predmeti načinjeni od stakla nerijetko su se odlikovali ljepotom i elegancijom. Sve je ovisilo o umješnosti svakog pojedinog staklara, o njegovu nadahnuću i maštovitosti. Kreativnost staklara manifestirala se u sposobnosti kombiniranja boja i kreiranja oblika, čega nije bilo u tolikim količinama u drugim materijalima koji su bili u uporabi.

U rimsko doba staklo je izrađivano posvuda diljem Carstva, podjednako na Apeninskom poluotoku, kao i u vrlo dalekim provincijama. Najpoznatija proizvodna središta ipak su se, čini se, nalazila na italjskom tlu te u Siriji, ali ništa manje nisu bili poznati niti proizvodi s područja Germanije, krajevima oko rijeke Rajne. Zanimljivo je da su i na istočnojadranskoj obali zabilježeni tragovi staklarske proizvodnje, s razvijenim staklarskim aktivnostima u nizu lokalnih radionica. U tomu je, po svemu sudeći, prednjačila Akvileja, ali proizvodnja stakla nije mimošla niti neka značajna urbana središta u hrvatskom dijelu provincije Dalmacije poput Salone, Jadera i nekih drugih urbanih aglomeracija. U Dalmaciji, a jednako tako i u Panoniji, primjerice u Sisciji, uz proizvodnju je značajan, također, bio i import staklene robe iz različitih područja Carstva, iz Italije, Galije i Germanije, odnosno Egipta, Sirije, Cipra te drugih krajeva u kojima je bila razvijena proizvodnja stakla. U mnogim hrvatskim muzejima pohranjeni su brojni stakleni predmeti antičke provenijencije, a u najvećem broju čini se da potječu iz rimskodobnih nekropola istraženih na području Zadra, rimskog Jadera, kao i iz njegove okolice.

Arheološki muzej u Zagrebu također posjeduje bogatu zbirku antičkog stakla, a posebnu cjelinu čine stakleni predmeti otkriveni, zajedno s drugim karakterističnim grobnim priložima, prije više od stotinu godina na području Bakra, u grobovima tamošnje rimske nekropole. Taj materijal nije, međutim, sustavno i na suvremen znanstveni način temeljito valoriziran. Nakon što je nedavno taj dio fundusa revidiran, sređen, a u nekim slučajevima i konzervatorski obrađen, stvoreni su uvjeti za njegovu potpuniju znanstvenu obradu, prvu nakon izvješća don Šime Ljubića o arheološkim iskopavanjima u Bakru, koji su objavljeni u svescima glasila zagrebačkog Muzeja, odnosno Hrvatskog arheološkog društva, iz ranih osamdesetih godina 19. st. U ovoj monografiji obrađeno je 178 različitih primjeraka, koji potječu iz prvih nekoliko stoljeća nove ere, zaključno s 3. st., kad

example, epigraphically, as well as in some literary sources, where the notes of Pliny the Elder, Strabo, and others should particularly be emphasized. It is necessary to keep in mind that the invention of the glassblowing pipe proved decisive for the mass production of glass accessible to a broad spectrum of society. This appears to have occurred during the 1st century BC. The use of the pipe allowed glass to be blown, which was a significant technological advance for its production and increasingly widespread and varied application. In this manner, glass ceased being a luxurious material accessible only to the select privileged social classes, and instead became a good intended for everyday use, available to almost all strata of the population. In later periods, in addition to the manufacture of vessels for various purposes, glass was also in widespread use in the production of jewellery, as well as in the increasingly popular glyptics. Its fragility and breakability were certainly negative traits, but the advantages in the use of glass products outweighed the flaws of other materials that were utilized for similar purposes. Other than their practical assets, such as minimal weight, transparency, and particularly non-porosity, because of which the contents stored in glass vessels were not subject to changes in smell or taste, objects made of glass were often distinguished by their beauty and elegance. Everything depended on the artistry of each individual glassworker, on his inspiration and imagination. The creativity of a glassworker was manifested in the ability to combine colors and create forms, which did not exist to such an extent in working with the other materials that were in use.

In the Roman period, glass was manufactured everywhere throughout the Empire, just as much in very distant provinces as in the Apennine peninsula. The most famed production centers nonetheless appear to have been located on Italian territory and in Syria, but products were equally well known from Germania, in the region around the Rhine River. It is interesting that traces of glass production have been noted on the eastern Adriatic coast, with developed glassworking activities in a series of local workshops. Such manufacturing was evidently dominated by Aquileia, but glass production did not bypass any important urban center in the Croatian part of the province of Dalmatia, such as Salona, Iader, and certain other urban agglomerations. In Dalmatia, and equally in Pannonia, for example in Siscia, along with local production, the import was also significant of glass goods from various regions of the Empire, from Italy, Gaul, and Germania, as well as from Egypt, Syria, Cyprus and other areas where the production of glass was highly developed. Many Croatian museums contain numerous glass items of classical provenience, and the greatest quantity seems to come from the Roman period cemeteries excavated in the Zadar area, the Roman Iader, and its vicinity.

The Archaeological Museum in Zagreb also possesses a rich collection of Roman glass, and one particular segment consists of glass artifacts discovered together with other characteristic grave goods more than a hundred years ago in Bakar, in the graves of the Roman necropolis there. This material, however, had never been evaluated systematically and in a modern scientific manner. After this part of the collection had recently been revised, arranged, and in some cases conserved, the conditions were met for its more complete scientific study, the first after the reports of Mon. Šime Ljubić about the archaeological excavations in Bakar, which were published in the volumes of the journal of the museum in Zagreb and the Croatian Archaeological Society in the early eighties of the 19th century. This book deals with 178 different specimens that come from the first several centuries AD, concluding with the 3rd

bakarska nekropola očigledno prestaje biti ukapalištem tamošnjeg stanovništva.

Nekoliko je osobitosti koje bi, kad je o ovome svesku riječ, trebalo izdvojiti i po kojima se on razlikuje od prethodnih. Možda je najzanimljiviji podatak što je suizdavač ovog sveska Univerza na Primorskem, Inštitut za dediščino Sredozemlja – Znanstveno raziskovalno središče Koper, partner s kojim smo surađivali u objavljivanju ovog sveska, a koji se u razmjerno kratkoj povijesti već dokazao kao uspješan nakladnik različitih publikacija s arheološkim sadržajem. Druga osobitost, na neki način usko povezana s prethodnom, očituje se u tome što je jedan od autora, uz Zorana Gregla iz zagrebačkog Muzeja, Irena Lazar, također dugogodišnji muzejski djelatnik, a od nedavna i sveučilišni nastavnik i ujedno vrsni poznavatelj antičkog stakla. Arheološki muzej na taj je način ostvario suradnju s tom vrlo ambicioznom mladom slovenskom visokoškolskom institucijom. Podsjetio bih u ovoj prigodi da je sličan oblik suradnje već zabilježen u svesku koji je bio posvećen odabranim grčkim vazama iz muzejske Antičke zbirke, a u kojemu je Muzej uspješno surađivao sa stručnjacima iz Muzeja Louvre u Parizu. Istaknuo bih još jednu osobitost ovog sveska: autori su, naime, odlučili njegov sadržaj obogatiti i poglavljem s reprintom davno objavljenog Ljubićeva teksta o iskopavanjima koja su bila obavljena na nekropoli u Bakru.

Osjećam naposljetku potrebitim zahvaliti se prethodno spominjanim autorima na trudu što su ga uložili u pripremu sveska, a zatim i urednici sveska Vesni Herak te recenzentima Branki Migotti i Mitji Guštinu. Istaknuo bih i važan doprinos Zrinke Znidarčić koja je obavila restauraciju dijela obrađene građe, kao i muzejskog fotografa Igora Krajcara koji je autor objavljenih fotografija. Zahvaljujem se, također, Andreji Izlakar i Miljenki Galić, autoricama objavljenih crteža te Marini Gregl, suautorici kataloškog dijela teksta. Zahvaljujem se, dakako, i svima ostalima koji su na bilo koji način pridonjeli objavljivanju sveska, a od kojih su neki spomenuti u impressumu ove vrijedne publikacije. Objavljivanje sveska ne bi, dakako, bilo moguće bez odgovarajuće financijske potpore, na čemu je potrebno izraziti zahvalnost Ministarstvu kulture RH i Gradskom uredu za obrazovanje, kulturu i šport Grada Zagreba.

Zaključio bih s nadom da će svezak u cijelosti ispuniti očekivanja te da ostaje na tragu onoga što se željelo ostvariti sustavnim objavljivanjem muzejske građe, odnosno novom valorizacijom pojedinih skupina spomeničkog materijala iz bogatog muzejskog fundusa. Vjerujem da će i ovaj svezak poslužiti kao jedna od karika u dugačkom lancu kataloško-monografskih izdanja planiranih u skoroj budućnosti, u kojima bi na sličan način trebali biti objavljivani dijelovi muzejskog fundusa koje u takvom obliku nije moguće obraditi i predstaviti u drugim muzejskim serijama ili povremenim pojedinačnim izdanjima.

Ante Rendić-Miočević

century, when the Bakar cemetery evidently ceased to be the graveyard for the inhabitants of that time.

Several special features of this volume distinguish it from preceding ones. The most interesting is perhaps the fact that the co-publisher of this volume is the University of Primorska, Institute for Mediterranean Heritage – Scientific Research Centre Koper in Slovenia, a partner with whom we have cooperated in the publication of this volume, which in a relatively short period has proven to be a successful publisher of various publications with an archaeological content. A second point of interest, closely connected to the first, lies in the fact that one of the authors, along with Zoran Gregl from the AMZ, is Irena Lazar of the above institution, who had previously worked for many years as a senior museum curator, very successfully specializing in Roman glass, and who recently has become a university professor. In this manner the Archaeological Museum has entered into cooperation with this very ambitious newly founded Slovenian institution of higher learning. It should be noted on this occasion that a similar manner of cooperation had already taken place in reference to a previous volume that had been dedicated to selected Greek vases from the Classical Department of the Archaeological Museum in Zagreb, in which the museum successfully collaborated with experts from the Louvre Museum in Paris. Yet another unusual feature of this volume should also be mentioned: the authors decided to enrich its contents with a reprint of the original text by Ljubić published long ago about the excavations that had taken place at the necropolis in Bakar.

In conclusion, the necessity arises of thanking the previously mentioned authors, Zoran Gregl and Irena Lazar, for the effort that they invested in the preparation of the volume, along with the editor of the volume, Vesna Herak, and the reviewers, Branka Migotti and Mitja Guštin. I would also like to note the important contribution of Zrinka Znidarčić, who carried out the restoration of part of the material in question, as well as the photographer of the museum, Igor Krajcar, who is the author of the published photographs. Further thanks are due to Andreja Izlakar and Miljenka Galić, for the drawings of the material, and Marina Gregl, co-author of the catalogue section of the text. I would also like to thank all those who in any manner contributed to the publication of the volume, some of whom are mentioned in the acknowledgement page of this valuable publication. The publication of the volume would not have been possible without financial support, for which gratitude must be expressed to the Ministry of Culture of the Republic of Croatia and the Municipal Office for Education, Culture, and Sport of the City of Zagreb.

I shall conclude with the hope that this volume will entirely fulfill expectations and will continue the aim of what we wanted to achieve with the systematic publication of museum material, in fact representing a new assessment of individual groups of artifacts from the rich collections of the museum. I believe that this new volume will also serve as one of the links in a long chain of catalogue and monographic publications planned in the near future, where segments of the museum collections that are not suitable for analysis and presentation in other museum series or occasional individual publications will be published in a similar manner.

Ante Rendić-Miočević

Zoran Gregl

Rimska nekropola Bakar

The Roman Cemetery of Bakar

Arheološki lokalitet Bakar, zajedno s bližom okolicom, evidentiran je u stručnoj literaturi još od 19. stoljeća.¹ Sam grad smješten je u dubokom zaljevu koji više podsjeća na norveške fjordove nego na istočnu obalu Jadranskog mora i poznat je po svojoj dugogodišnjoj pomorskoj tradiciji, lovu na tune i izgradnji tzv. »prljave« industrije u razdoblju nakon Drugog svjetskog rata. Još godine 1849. osnovana je Državna javna nautička škola (Danas pomorska škola Bakar), od lova na tune ostale su kao turistička atrakcija ribarske promatračnice (tzv. *tunere*), dočim je zagađivačka industrija, posebice koksara, devedesetih godina 20. stoljeća napokon zatvorena. No sreća u nesreći je bila da se zbog ekološki neprihvatljivih industrijskih postrojenja nije masovno razvio turizam i izgrađivale kuće za odmor pa je raster ulica i stara kamenom građena gradska jezgra ostala relativno dobro sačuvana.

Geomorfološki promatrano, Bakarski zaljev položen je na mezozojsko-paleogenoj vapnenačkoj osnovi preko koje su »stalozene nepropusne naslage paleogenog fliša (laporci, glinci i pješčenjaci) koji su najčešće u reljefu sniženik.«² U povijesnom kontekstu gledano, zahvaljujući iznimno povoljnom geostrateškom položaju, odlično zaštićenoj luci i ostalim povoljnim

The archaeological site of Bakar and the surrounding vicinity had already been documented in the professional literature from the 19th century.¹ The town of Bakar is located in a deep enclosed bay that is more reminiscent of Norwegian fjords than the rest of the eastern coast of the Adriatic Sea, and is known for its lengthy maritime tradition, tuna fishing, and unfortunately, the construction of »dirty« industrial facilities after the Second World War. In 1849, the State Public Nautical School was founded (today the Nautical Academy of Bakar), all that remains of the tuna fishing are the fishermen's lookouts (called *tunere*) kept as tourist attractions, while the polluting industries, headed by the coke plant, were finally closed in the 1990s. Luckily enough, because of the ecologically unacceptable industrial plants, mass tourism was never developed in the area, nor were vacation homes built, and hence the layout of the streets and the old stone-built town center have remained relatively well preserved.

In geomorphological terms, the Bay of Bakar is located on a Mesozoic-Paleogene limestone bedrock over which were »layered impermeable deposits of paleogene flysch (marl, clay, and sand based), which were most often reduced in relief.«² From the historical point of view, thanks to its favorable geo-strategic position,

¹ F. Pilepić, *Odkriće rimskoga groblja u Bakru*. Viestnik Hrvatskoga arheološkoga društva (dalje: VHAD), god. III, str. 15–16, Zagreb, 1881.; Š. Ljubić, *Arheološka izkapanja u Bakru*. VHAD, god. III, str. 92–94, Zagreb, 1881.; isti, *Arheološko izkopavanje u Bakru*. VHAD, god. IV, str. 1–9, 48–54, 66–67 sa 4 table.

² Geografija SR. Hrvatske, knj. 5, str. 9, Zagreb, 1975.

¹ F. Pilepić, *Odkriće rimskoga groblja u Bakru*. Viestnik Hrvatskoga arheološkoga društva (further: VHAD), year III, pp. 15–16, Zagreb, 1881.; Š. Ljubić, *Arheološka izkapanja u Bakru*. VHAD, III, pp. 92–94, Zagreb, 1881.; Idem, *Arheološko izkopavanje u Bakru*. VHAD, IV, pp. 1–9, 48–54, 66–67, with 4 plates.

² Geografija SR Hrvatske, vol. 5, p. 9, Zagreb, 1975

Priznanje vis. kralj. zem. vlade za one, koji su podupirali arkeol. izkapanja u Bakru. — Na predlog ravnateljstva arkeol. odjela zem. muzeja od 30. lipnja t. g. visoka vlada svojim odpisom od 12. rujna br. 3846 blagoizvolila je odrediti, neka isto ravnateljstvo u njezino ime „kotarskomu sudcu Vladoji Vodvarzki, odvjetniku Dru. Franji Pilepiću, prof. Luki Roiću, gradskom liječniku Dru. Ivanu Benzanu, liekarniku Jakovu Batistiću, prof. Narcisu Daminu, Arturu Dujmoviću, Ivanu Bonetiću, Damjanu Andrijaniću, Franji Penku i poglavarstvu sl. i kr. grada Bakra, koji su radnje oko izkapanja arkeologička u Bakru revno podpomagali, i povoljnomu uspiehu pripomogli, pismeno izrazi priznanje kr. zem. vlade“. Muzealno ravnateljstvo dakako veoma rado je taj visoki nalog izvršilo.

prirodnim uvjetima za život, taj je kraj Hrvatskog primorja bio naseljen još u prapovijesti. U razdoblju Rimskog Carstva neki autori na osnovi otkrivene paljevinske nekropole i antičkih itinerara u Bakar smještaju antičko naselje Volcera.³ Današnji grad prvi put se spominje u *Vinodolskom zakoniku* iz 1288. godine, što je ujedno i prvi pisani spomen Bakra.⁴ Unutar starogradske jezgre 1530. godine sagrađen je srednjovjekovni feudalni kaštel – tada u vlasništvu hrvatskih plemićkih porodica Zrinski i Frankopan – ispred kojeg se nalazi Trg na kojem su u kolovozu 1880. godine pronađeni prvi paljevinski grobovi.

Nalazi su otkriveni slučajno, zahvaljujući prosvječenosti nekolicine domoljuba koji su obavijest odmah prosljedili Šimi Ljubiću, tadašnjem ravnatelju Muzeja u Zagrebu koji je reagirao promptno, a nalaznici su dobili priznanje i zahvalnicu od Visoke kraljevske zemaljske vlade.⁵

Prvi ciglom obzidani grob otkriven je nakon što su zaprežna kola puna tereta za luku u Bakru »propala« u zemlju a znatiželja je potaknula odvjetnika dr. F. Pilepića da započne istraživanja i otkrije prvu žaru.

Idealna je situacija za svakog arheologa da se interpretacija određenog lokaliteta pojavi kao rezultat vlastitih istraživanja, što podrazumijeva kompletnu dokumentaciju i sliku o terenu (terenski dnevnik, foto-dokumentacija, crteži, planovi itd.). Manje je zahvalna situacija kad se objava materijala zasniva na osnovi tuđih istraživanja pa sve ovisi o kvaliteti naslijeđene terenske dokumentacije – ako je podataka dovoljno i publiciranje je kvalitetno. Kudikamo je najnezahvalnija situacija u kojoj terenske dokumentacije uopće nema, odnosno nije sačuvana ili je odvojena od materijala i zagubljena. U tom slučaju preostaje jedino tipološka analiza i obrada određene vrste materijala na osnovi analogija. To je slučaj i s nekropolom u Bakru. Šime Ljubić⁶ je odmah u lipnju 1881. godine preuzeo od Pilepića istraživanje, a o preliminarnim rezultatima piše s oduševljenjem... »Radnja, koja nije više trajala od 15 dana, uzplodila je tako sjajno, da je svaku nadu daleko nadmašila...«⁷, ali od podataka s istraživanja o okolnostima nalaženja nije ostalo ništa sačuvano. Iznimka je nekoliko crteža grobnih oblika prikazanih na tabli I te nekoliko crteža materijala na tablama II–IV, za koje možemo pretpostaviti da su načinjeni

well-protected harbor, and other excellent natural conditions necessary for existence, this section of the Hrvatsko Primorje (Croatian Littoral along the northern Adriatic coast) had first been settled in the prehistoric period, while for the period of the Roman Empire, some authors on the basis of the discovered cremation cemetery and various Roman itineraries would place the Roman settlement of Volcera at Bakar.³ The present town is mentioned for the first time in the Vinodol Codex from 1288, which is also the first written mention of Bakar by name,⁴ and within the nucleus of the old town a medieval feudal castle was built in 1530 – then owned by the Croatian noble Zrinski and Frankopan families – in front of which was the square where the first cremation graves were discovered in August 1880.

The finds were discovered by chance, and thanks to several enlightened patriots who immediately passed the news on to Šime Ljubić, then director of the National Museum in Zagreb, who in turn reacted promptly, the finders received recognition and a scroll of thanks from the High Royal Provincial Government.⁵

The first brick built tomb was discovered after a horse-drawn wagon full of cargo for the harbor in Bakar »sank« into the earth, causing the curiosity inspired lawyer Dr. F. Pilepić to begin excavating and discover the first urn.

It would be ideal for every archaeologist if the interpretation of a given site resulted from his or her very own excavation, with full control over the entire documentation and recording of the site (field notes, photo & video documentation, drawings, plans, etc.). It is a much less ideal situation if the publication of the material actually involves someone else's excavation, at which point everything depends on the quality of the »inherited« field documentation – if sufficient data exists, then the publication can be of high quality, but the situation is immeasurably more thankless if no field documentation exists at all, if it was not preserved, or had been separated from the other material and lost. In such a case all that remains is typological analysis and the study of certain types of material on the basis of analogies. This was the situation with the cemetery at Bakar. Šime Ljubić⁶ immediately in June 1881 took over the excavations from Pilepić, and wrote about the preliminary results with enthusiasm... »The work, which did not take longer than 15

³ Š. Ljubić, *Arkeologičko izkapanje u Bakru*. VHAD god. IV, str. 5–7, Zagreb, 1882.

⁴ M. Kostrenčić, *Vinodolski zakon*. Rad JAZU, knj. 227, 110–230, Zagreb, 1923.

⁵ VHAD, god. III, str. 126, Zagreb, 1881.

⁶ O Š. Ljubiću vidi u: *Muzeopis 1846–1996.*, str. 25, Zagreb, 1996.

⁷ VHAD, god. III, str. 93, Zagreb, 1881.

³ Š. Ljubić, *Arkeologičko izkapanje u u Bakru*. VHAD, IV/1, pp. 5–7, Zagreb, 1882

⁴ M. Kostrenčić, *Vinodolski zakon*. Rad JAZU, book 227, 110–230, Zagreb, 1923

⁵ VHAD, III, p. 126, Zagreb, 1881

⁶ About Š. Ljubić, see: *Muzeopis 1846–1966*, p. 25, Zagreb, 1996.

Odkriće rimskoga groblja u Bakru.

Prvi izvještaj o tom otkriću došao je ravnatelju zem. muzeja od veleuč. g. Dra. Fr. Pilepića, te glasi ovako:

»Veleučeni gospodine! Na istočnoj strani Bakra uz Luizinsku cestu jest tako zvani trg. Zemljište nije mu ravno, već se po malo prama vinogradom diže.

Stariji ljudi pripovjedaju, da je nekada tuj bilo trsje i ovo zemljište bilo ravnije, i zato i dolnji kraj uz sadašnju Luizinsku cestu ležao je više nego li sada, jer su stranom da cestu sagrađe a stranom da dobiju zemlje za sadašnje groblje, zemlju izkopali, i zato nastala je mala strmina prama cesti, koja se sada vidja. Spomena neima, da je tuj bilo kada kakovo groblje; već ljudi pripovjedaju, da na istočnom kraju toga zemljišta, gdje sada je jedna kuća uzidana, našlo se različitih grobnica i žara. Ali koliko sam razpitao, nisam mogao doznati, kakove bijahu grobnice.

Njeki dan po luizinjskoj cesti prolazeća kola išla su u stran prama trgu, i pod konjskim kopitom propala se ponješto zemlja. Njekoji iz znatiželjnosti počeli su kopati i naišli su na staru grobnicu ciglom ozidanu.

Našla se poveća žara, u kojoj je bila druga manja liepo izradjena i pokrovcem, koj njoj liepo na vrat prilaže, zatvorena. Našla se i rimska svetiljka i malena bočica od stakla. Cigla, kojom je bila grobnica ogradjena, se je porazbila, a stranom bijaše porazbita, jer je bila niti pol stope pod zemljištem. Napisa niti znaka nije imala nikakova. Cigla je liepe fine crljene zemlje, a ima okolo obod, kako da je služila da pokrije grobnicu, i da može liepo prileći.

Ovim otkrićem prinukovani nekoliko nas sabrasmo nekoliko forintih, te smo ondje izkapanje nastavili.

Jučer pod večer našli smo jednu svetiljku zemljenu, na kojoj se čita napis FORTIS liepo utisnutimi u relievu slovi; uz svetiljku našli smo malu staklenku dugim vratom, kakova se i dan prije

našla. Našla se i druga svetiljka, na kojoj je liepi konj utisnut; i jednu oveću, malomu lončiću naličnu staklenu posudicu.

Uz ove stvari našla se žarica, zemljena posuda sa uzkim vratom i jednom ručicom po prilici 20 centimetra. A nedaleko od nje bila je oveća razbita žara, u kojoj bijaše kosti maloga djeteta, a uz sve to bilo je ugljena i crne zemlje.

Danas pak smo nastavili izkapanje, te prije svega naišli smo na okostnicu odrasla čovjeka, koja se razpršila, jedino zubi su dobri i doljna čeljust. Uz samu okostnicu našli smo ciglu dugačku 59 centim., koja je ležala nješto koso u zemlji. Odstraniv ovu ciglu, opazismo razpucanu oveću žaru, a nad njom ležala je cigla dugačka 62 centimetra, nu odbita, a po prilici imala bi biti široka 49 centimetra. Na ovoj cigli utisnuto je liepimi velikimi slovi rieč Solonas u ovakovoj formi SOLONAS; slova su do dva centimetra visoka, a veoma ukusna. Ploča ima okolo rub.

Maknuv ploču, oslobodili smo žaricu, koja je pod njom bila. Nu žalibože sva je bila razpucana, jedino dno njoj se spasilo. U njoj je bila druga žarica, jednom ručicom i podugatim grlom, visoka 20 cmt. a u promjeru na trbuhu 14 centimetra. Usta grla imaju u promjeru 5 cmt. Uz ovu žaricu, koja je sva razpucana, našli smo ostanke posudice nalične lončićim sa pokrovcem, kakova

se i u prijašnjoj grobnici našla. Uz ove posude našla se oveća staklena bočica visoka do 15 centim. dugim vratom. Nalična je posve malim bočicama, jedino što je duplo veća. Žalibože je ona potrta, kako i druga staklena posudica nalična lončiću, kakova je u drugoj grobnici nadjena. Napisa neima nigdje nikakovoga. Uz truplo našao se bakren novac, na komu je na jednoj strani vidljiva glava mlada ovjenčana čovjeka. Napis, koj je naokolo, nismo mogli pročitati, a što je na drugoj strani, nismo još razabrali.

Sve ove stvari su oštećene, jer su niti jednu stopu izpod površenice ležale, pače lubanja čovjeka nije bila niti pol stope duboko.

Ovo Vam, velećenjeni gospodine, na brzu ruku javljam, moleći Vas, da nam dadete kakav naputak, ako mislite, kako da nastavimo započet posao; ili pako, ako Vas sreća na primorje nosi, da nam se ovdje najavite, nebili smo davninu našega Bakra razbistrili. Budemo Vam zahvalni.

Primate, veleuč. gosp. izraz mojega najodličnijega počitanja.
U Bakru, 24. kolovoza 1880.

Dr. Franjo Pilepić,
odvjetnik i javni bilježnik.

Usljed ove obavjesti ravnatelj nar. arkeolog. muzeja odjuri u Bakar, da ona izkapanja razvidi, i ondješnjim srećnim i plemenitim obretnikom te arkeološke rude u pripomoć bude. Pod ravnanjem dakle prof. S. Ljubića nastavila su se izkapanja na muzealne troškove za nekoliko dana te nenadanim uprav sjajnim uspjehom. Mi ćemo o njih potanko razložiti u sljedećem broju Viestnika. Dužnost nam je međjutim najtopliju hvalu izreći onim odličnim muževom, koji su novcem pripomogli, da se ona ruda odgrne i njom već do sada liepo obogate sbirke nar. zem. muzeja, navlastito pako Dru. Franji Pilepiću, Dru. Ivanu Benzonu grad. liečniku i g. Jakovu Batistiću, liekaru u istom Bakru, koji su neutrudljivo i sami u izkapanjih sudjelovali.

Uredništvo.

po dolasku u Zagreb.⁸ Ljubić sam spominje dopremu materijala u Muzej: ...»obilna žetva toga izkapanja došla je već u Zagreb u četiri velika sanduka uz osam kamenitih ogromnih žara, te se sada čisti i popravlja.«⁹ Preostale su samo objave u muzejskom glasilu¹⁰ u kojima su nalazi razvrstani prema materijalu od kojeg su načinjeni, oskudan opis i dimenzije. Nažalost, nije ostala sačuvana niti jedna grobna cjelina, što je za precizniju dataciju groba najvažnije, osobito ako je u njemu i novac – što daje barem donju vremensku granicu – *terminus ante quem non*, no moramo se prisjetiti činjenice da je iskopavanje i preliminarna objava provedena potkraj 19. stoljeća, a naš rad početkom 21. st. Taj princip zadržao je Ljubić i pri deponiranju materijala u muzejska spremišta pa je tako odvojena keramika od stakla, svjetiljki, novca, kamenih urni, brončanih predmeta itd. Prema Ljubićevoj klasifikaciji, kategorije predmeta publiciranih u *Viestniku IV* su sljedeće:

I. Dragocienosti (str. 7)

II. Predmeti od raznih kovina (str. 7–9)

III. Predmeti od kosti i od drva (str. 9)

days, was so fruitful that all hopes were greatly exceeded...»,⁷ but nothing has remained preserved about the excavations, their context, and the circumstances of discovery. The only exceptions are several drawings of grave forms shown on Pl. I, and several drawings of material on Pl. II-IV, which can be assumed to have been made after his return to Zagreb.⁸ Ljubić himself mentions bringing the material to the Museum: the abundant harvest from this excavation arrived in Zagreb in four large trunks, along with eight enormous stone urns that are now being cleaned and conserved.⁹ All that has remained are merely the reports in the museum journal,¹⁰ where the finds are arranged according to the material from which they were made, with a scanty description and the dimensions. Unfortunately, not a single grave unit has been preserved, which is the most important factor for a precise dating, particularly if contained a coin – which gives us at least the lower chronological frame – the *terminus ante quem non*, but it must be remembered that the excavation and preliminary publication occurred at the end of the 19th century, while our work takes place in the 21st century. The same principle was utilized by Ljubić in storing the material in

⁸ VHAD, god. IV, table I-IV, Zagreb, 1882.

⁹ Vidi bilj. 8.

¹⁰ Vidi bilj. 1.

⁷ VHAD, III, p. 93, Zagreb, 1881.

⁸ VHAD, IV, pl. I-IV, Zagreb, 1882.

⁹ See n. 8.

¹⁰ See n. 1.

IV. *Staklenke: Zdjele. Tanjuri. Čaše. Šalice. Boce. Igle.*
(str. 48–52)

V. *Zemljano posudje: Tanjuri. Zdjele.* (str. 53–54)
Vrčevi i čupovi. Lonci. Viedra i žare. Poklopci. Posude zemljene osobitog oblika. (str. 66–70)

VI. *Svietiljke./Novac.* (str. 70–76)

VII. *Cigle.* (str. 77)

VIII. *Predmeti od kamena.* (str. 77)

Za ovu obradu nekropole izdvojili smo, u skladu s mogućnostima, samo staklene predmete koji su za tu prigodu (osim nekoliko iznimaka) kompletno fotografirani, dočim o ostalim predmetima i grobnim oblicima možemo donositi pretpostavke i zaključke samo na osnovi skromne Ljubićeve ostavštine. Tijekom obrade i identifikacije materijala u depou Arheološkog muzeja u Zagrebu angažman dipl. arheologinje Marine Gregl iz Zagreba bio je od neprocjenjive važnosti. Bez njezine pomoći ovako zahtjevan posao ne bi bilo moguće obaviti, kao što ni predmeti i njihovi oblici ne bi bili dovoljno jasni bez crteža i tabli koje je nacrtala Andreja Izlokar iz Celja.

Poljana... »na kojoj se je izkapanje izvelo, načina je prave pačetvorine...«, dimenzije su joj 100 x 40 m, istražena površina je 40 m u kolovozu 1880. te 200 četvornih metara u lipnju 1881. godine, što zahvaća otprilike 1/8 cijelog prostora u njegovom jugozapadnom dijelu, dočim sondiranja u drugim dijelovima nisu dala nikakve rezultate. U nedostatku tlorisa nekropole nismo u mogućnosti prikazati raspored grobova no na tab. I, crtež A, – jasno su vidljivi zidovi grobnih parcela – ili kako ih Ljubić naziva »nutarnji diobni zidovi«. Ta grobna parcela relativno je mala (6 x 5 m) pa pretpostavljamo da su se unutar nje nalazili ranocarski paljevinski grobovi. Što se tiče oblika grobova, sa sigurnošću možemo reći da je otkrivena 21 kamena urna, među kojima je samo jedna četvrtasta a ostale su okrugle i imale su poklopac (Reprint – tab. I, crtež f). Kako nam se čini, dosta je bilo grobova građenih od opeka. Zastupljena su dva osnovna oblika koji su prikazani na tabli I, crteži a, b, c, d, e i f:

- četiri okomito zabodene opeke čine četvrtastu grobnu komoru, peta ima funkciju pokrova a šesta podnice
- ukoso postavljene dvije ili četiri ukoso postavljene opeke koje se na vrhu priljubljuju i prekrivene su kupama kanalicama a dno je groba također popođeno opekama ili običnom zemljom.

Za prvi tip možemo tvrditi da je riječ isključivo o paljevinskom ukopu, drugi tip također može biti paljevinski grob, no ukoliko je u dužinu poslagano više koso položenih opeka, ispod se može pronaći i skelet, što pak sugerira na mogućnost pokapanja i u kasnocarskom razdoblju. Među opekama pojedine su (njih 12) imale utisnute žigove proizvođača:

NERONS CLA PN; TI PANSINA; PANSIANA; SOLONAS

Otkriveni su među inim i najjednostavniji grobovi – tzv. ukop u običnu zemljanu jamu – što je vrlo čest oblik groba i na ostalim paljevinskim nekropolama, ali nismo sigurni da ih je Ljubić izdvajao kao grobne cjeline, jer spominje da se... »odkrilo mnogo velikih žara kamenitih i zemljenih i u grobovih i do njih i na samu...«. ¹¹ Običaj je da se u zemljanu jamu polaže urna s ostacima spaljenih kostiju pokojnika. Poputbina

the museum storerooms, and hence the pottery is separated from the glass, the lamps, coins, stone urns, bronze objects, etc. According to Ljubić's classification system the categories of the objects published in the volume *Viestnik IV* are as follows:

- I. Valuables (p. 7)
- II. Objects of various metals (pp. 7–9)
- III. Objects of bone and wood (p. 9)
- IV. Glass vessels: Bowls. Dishes. Tumblers. Cups. Flasks. Pins. (pp. 48–52)
Clay vessels: Dishes. Bowls. (pp. 53–54) Jugs and cups.
Pots. Pails and urns. Lids. Special forms of clay vessels. (pp. 66–70)
- V. Lamps./Coins. (pp. 70–76)
- VI. Brick. (p. 77)
- VII. Stone objects. (p. 77).

This study of the material from the cemetery concentrates specifically, in correspondence with our possibilities, on only the glass objects, which have been fully photographed (with only a few exceptions), while hypotheses and conclusions can be offered for the other material and the grave types only on the basis of the modest information left by Ljubić. The sorting and identification of the material in the storerooms of the Archaeological Museum in Zagreb profited immensely from the aid of the archaeologist Marina Gregl, B.A., from Zagreb. Without her help it would not have been possible to carry out such a demanding task, nor would the artifacts and their forms have been sufficiently clear without the illustrations and plates drawn by Andreja Izlokar of Celje.

The plot »...where the excavation was performed, is a true parallelogram...«, the dimensions were 100 x 40 m, and 40 square meters were excavated in August 1880, and 200 square meters in June 1881, encompassing about 1/8 of the entire area in its southwestern part, while test trenches in other sections offered no results. Lacking a plan of the cemetery, we cannot depict the layout of the graves, but on plate I, drawing A, the walls of grave lots are clearly visible, or as Ljubić called them, the »inner partition walls«. This grave lot was relatively small (6 x 5 m), and it is hypothesized that it contained early Imperial cremation graves. In terms of the shape of the graves, it can be stated with certainty that 21 stone urns were discovered, only one of them square, while the others were circular and had lids (Pl. I, drawing f). It seems that many of the graves were built of brick, and two basic forms were represented, as shown on plate I, drawings a, b, c, d, e, and f:

- Four vertically placed bricks create a square grave chamber, while a fifth brick was used as a lid, and a sixth for the floor;
- Two slanted bricks or four obliquely placed bricks that meet at the top and are covered with tiles, while the base of the grave was also floored with brick or ordinary earth.

The first type can be defined exclusively as a cremation burial, while the second type can also be a cremation grave, but if several more slanted bricks are arranged lengthwise, a skeleton grave could well be discovered underneath, which further indicates the possibility of burial in the late Imperial period. Some individual bricks had stamps of their manufacturers (a total of 12):

NERONS CLA PN; TI PANSINA; PANSIANA; SOLONAS

The simplest types of graves were discovered among the others – burial in an ordinary earthen pit – which is a very common form of grave at other cremation cemeteries, but it is not certain that Ljubić distinguished them as grave units, as he mentioned that »many

¹¹ VHAD, god. IV, str. 3, Zagreb 1882.

(posude, fibule, novac i dr.) koja može biti u urni ili položena na dno jame uz nju, dok su posude, najčešće vrčevi s jednom ili dvije ručke, koji su bili pronalazeni »na samu« (po Ljubiću), recipijent u funkciji grobnog obreda (tzv. žrtva ljevanica) i obično su polagane na zemlju s vanjske strane groba.

Pronađena su i dva skeletna groba, ali bez popratnog materijala pa ih nije moguće datirati. Kako su otkopani odmah ispod površine, a iznad antičkog paljevinskog sloja, najvjerojatnije je riječ o naknadnim ukopima.

Osim reljefnih glinenih svjetiljki pronađene su i one s pečatima sljedećih proizvođača:

ATIME; ATIMETI; CANNEI; CASSI; COM/?/NIS; /CR/ESCES; CRESCES; C DESSI; FAOR; FORTIS; IANVAR; LITOGENE; LVCIVS; LVPATI; OCTAVI; PVLLI; SEXTI; STROBILI; VERI; VIBIANI

Vrlo je zanimljiv nalaz pet kamenih pločica za razmazivanje masti od seladonitnog tufa (Reprint – Tab. III, 29) koje zajedno s pincetom (Reprint – T. III, 28), žličicom (Reprint – tab. IV, 32) i sondom (Reprint – T. IV, 45) možemo sa sigurnošću atribuirati kao medicinski ili toaletni pribor,¹² dok Ljubić naziva »ploče brusaonice na način pačetvorine«.¹³

Zbog više nego oskudnih podataka o okolnostima nalaženja, grobnim oblicima i inventaru grobova, u vezi s datiranjem, tj. vremenom funkcioniranja nekropole, prisiljeni smo držati se Ljubićeve datacije koja je utemeljena na nalazima novca »... te spadaju na Nerona, Trajana, Adriana, Antonina, i Faustinu stariju – od god. 54 do god. 161 po Is. ...«.¹⁴ Međutim, dopuštamo mogućnost da je nekropola počela funkcionirati i ranije (već od Augusta), a neki grobni oblici – posebice grobovi od ukoso postavljenih tegula, ukoliko po dužini imaju paralelno posložene 3–4 opeke, upućuju na skeletno pokapanje – što predmnijeva i duži vijek trajanja nekropole možda čak i kroz cijelo 2. stoljeće. Revizijska istraživanja su u skorije vrijeme moguća¹⁵ pa se nadamo da bi ona mogla donijeti više svjetla u razrješavanju još nedokučenih odgovora na pitanja o lokalitetu Bakar.

U Arhivu AMZ naknadno je pronađeno (tijekom prosinca 2007. g.) izvješće Josipa Brunšmida o iskopavanju u Bakru koje je on proveo 1905. g., a vrlo je zanimljivo, ne toliko poradi materijala koji je tom prigodom pronađen, već poradi podataka koji donekle omogućuju ubiciranje tih lokaliteta.¹⁶

large urns were discovered, of stone and of clay, in the graves, and next to them, and on their own...«.¹¹ It was the custom to place the urn with the remains of the burnt bones of the deceased in an earthen pit, and the travelling provisions (vessels, fibulae, coins, etc.) could be in the urn or placed at the base of the pit next to it, while those vessels that were found »on their own«, most often jugs with one or two handles, represent containers that played a role in the funerary ritual, for sacrificial libations to the deceased, and were usually placed on the ground on the outside of the grave.

They were found in two skeleton graves, but without any accompanying material, so they cannot be specifically dated. As they were excavated immediately below the surface, and above the Roman cremation layer, they were most probably buried subsequently.

In addition to clay oil lamps with relief decoration, lamps with the stamps of the following manufacturers were also found.

ATIME; ATIMETI; CANNEI; CASSI; COM/?/NIS; /CR/ESCES; CRESCES; C DESSI; FAOR; FORTIS; IANVAR; LITOGENE; LVCIVS; LVPATI; OCTAVI; PVLLI; SEXTI; STROBILI; VERI; VIBIANI

Another very interesting find consisted of five stone tablets of celadonite tuff for spreading ointments (Pl. III, 29), which together with tweezers (Pl. III, 28), a small spoon (Pl. IV, 32), and a probe (Pl. IV, 45) can be classified with certainty as medical or cosmetic equipment (13),¹² while Ljubić called them »parallelogram sharpener plates«.¹³

The less than meager data about the circumstances of discovery, the grave forms, and the inventory of the graves means that in terms of dating the period when the cemetery was in function, we are forced to retain Ljubić's dating, which was based on the finds of coin »... of Nero, Trajan, Hadrian, Antoninus, and Faustina the Elder – from 54 to 161 AD...«.¹⁴ However, the possibility exists that the cemetery could have begun functioning earlier (from the reign of Augustus) and certain grave forms – particularly graves of slanted tiles where 3–4 parallel tiles were placed lengthwise – would indicate inhumation burial, which implies a longer period of existence of the cemetery, perhaps even throughout the entire 2nd century AD. Revisory excavations might take place shortly,¹⁵ and it is to be hoped that they could provide better illumination in solving still inscrutable questions about the site of Bakar-Sarazinovo (Roman period cremation cemetery).

The Archives of the AMZ were later (in December 2007) found to contain the report by Josip Brunšmid, the successor to Ljubić, about the excavations in Bakar that he carried out in 1905, which is very interesting, not so much in terms of the material discovered on that occasion, but because of information that to a certain extent enables locating the sites involved.¹⁶

¹² Z. Gregl, *Rimski medicinski instrumenti iz Hrvatske I*. Vjesnik Arheološkog muzeja u Zagrebu (dalje: VAMZ), 3. ser., sv. XV, str. 175–198, Zagreb, 1982.; isti autor: *Rimski medicinski instrumenti iz Hrvatske II* (Prilog poznavanju farmacije u provinciji Panoniji). VAMZ 3/XVI–XVII, 175–181, Zagreb, 1984.; isti autor: *Rimski medicinski instrumenti iz Hrvatske III*, *Histria antiqua XIV*, str. 31–37, Pula, 2006

¹³ VHAD, god. IV, str. 77, Zagreb, 1882.

¹⁴ VHAD, god. IV, str. 3–4, Zagreb, 1882.

¹⁵ Na usmenom podatku zahvaljujem kolegi Ranku Starcu iz Pomorskog i povijesnog muzeja u Rijeci.

¹⁶ Arhiv AMZ, fasc. Bakar

¹¹ VHAD, IV, p. 3, Zagreb, 1882.

¹² Z. Gregl, *Rimski medicinski instrumenti iz Hrvatske I*. Vjesnik Arheološkog muzeja u Zagrebu (further: VAMZ), 3. ser., vol. XV, pp. 175–198, Zagreb, 1982.; Idem: *Rimski medicinski instrumenti iz Hrvatske II* (Prilog poznavanju farmacije u provinciji Panoniji). VAMZ 3/XVI–XVII, 175–181, Zagreb, 1984.; Idem: *Rimski medicinski instrumenti iz Hrvatske III*, *Histria antiqua XIV*, pp. 31–37, Pula, 2006.

¹³ VHAD, IV, p. 77, Zagreb, 1882.

¹⁴ VHAD, IV, pp. 3–4, Zagreb, 1882.

¹⁵ I would like to thank my colleague Ranko Starac from the Maritime and Historical Museum in Rijeka for this information.

¹⁶ Archives of the AMZ, Bakar file.

K broj 327 od 19/12 1905.

izvještaj

Dru Josipa Bonničevića, ravnatelja arheološkoga odjela narodnoga muzeja u Zagrebu u iskopavanju u Bakru.

Boravec u kolovozu t. g. u hrvatskom primorju doznao sam sasvim slučajno, da je bravar Benac iz Krasice, rigolujući prošle zime svoj vinograd Sarazinovo u Bakru, našao mnogo bronzanih predmeta. Ova me je vijest potaknula, da se odvezem k Bencu, kod kojega sam na svoje začuđenje još iz 9 mjeseci našao i za narodni muzej na dar dobio jedno desetak pokidanih bronzanih posuda, što ih je — ne mogav ih u svom poslu upotrijebiti — sačuvao bio.

Uvidiv važnost toga našašća i želeći biti osobno prisutan kod otkopavanja grobova, kakovi se do sele u Hrvatskoj i Slavoniji još nikada nisu pod nadzorom stručnjaka prekopavali, ugovorio sam sa Bencem, da će nastavak kopanja (resp. rigolovanja) preuzeti narodni muzej, kojemu će i nađeni predmeti bez ikakove daljnje odštete pripasti. Radi neprestanih kiša bilo je i'lovasto zemlji, što tako promotno, da se je kopanjem moglo tekar 11. prosinca započeti a provodio sam ga sa 9-11 radnika sve do 15. prosinca.

Uspjeh prekopavanja nije me zadovoljio a sastoji u sljedećem:

1. Konstatovao sam, da je na novozasadjenom dijelu vinograda Sarazinova negda bilo veoma bogato pret, historijsko groblje drugoga (a možda već i prvoga) željeza,

noga doba, koje su neuputni radnici devastirali a predmete većim dijelom opet natrag u zemlju pobacali. Na samoj površini zemlje pokupio sam oveci broj oštećenih predmeta, koji su pri obrativanju ponovno na površinu dospjeli.

2. Oko početka današnje ere nalazilo se tamo drugo prethistorijsko groblje sa pokapanim mrtvacima, uz koje su bile od Benca dobivene posude. Ja sam našao jedan takov intaktan grob.

3. Još se mlade bili rimski grobovi sa spaljenim mrtvacima, koji potječu iz I. i II. stoljeća poslije Krista. Takovih sam grobova na Benčevu zemljištu našao tri, a na obližnjem Andreaničevom, koje je vlasnik slučajno istodobno oigolovao, pet.

4. Postigao sam zanimiv podatak i za lokalnu topografiju sredovječnoga Bakara, jer sam našao na fundamente jedne stare crkvice. To može biti samo crkvice sv. Nikole, koji se u XIV. vijeku i poslije spominje baš na Saracimovu, a za koju se znade, da je na početku XVIII. vijeka demolirana, kada se je kraj nje gradilo karolinska cesta, kojoj je djelomice na putu bila. Po jednoj rukopisnoj bilješci našlo se je oko nje tom prigodom mnogo ljudskih kostiju. U ja sam kraj nje našao na nekoliko već prije diranih grobova, kojima su mrtvaci bez škrinje i bez ikakvih priloga pokopavani bili, pa mi je veoma vjerojatno, da ti grobovi spadaju pod konac srednjega i na početak novoga vijeka.

Kod iskopavanja osvjedočio sam se, da je grobova pod br. 2 i 3. bilo negda više i u onom dijelu zemljišta, u kojem sam kopati mogao, ali da se je već davno kod kultiviranja loze na nje našlo i predmete povadilo ili uništilo. Uvidiv, da se daljnji posao ne bi na tom mjestu isplatio, završio sam iskopavanje i povratio sam se 16. pro, sinca u Zagreb.

U Zagrebu 19. prosinca 1905.

J. Jos. Brunsmir

VIESTNIK

HRVATSKOGA

ARKEOLOGIČKOGA DRUŽTVA.

GODINA III.



Viestnik

III



U ZAGREBU.

TISKARSKI I LITOGRAFIJSKI ZAVOD C. ALBRECHTA.

1881.

Šime Ljubić

Arkeologičko izkapanje u Bakru

Reprint

Arkeologička izkapanja u Bakru. — Prošle godine uprav čudnovatim načinom ušlo se je u trag rimskom groblju u Bakru. Obretnikom toga grobišta pravo rekši bijaše Dr. Franjo Pilepić, komu ide i ta prednost, što je prvi o tom otkriću obavijestio i ravnatelja hrv. arkeolog. muzeja u Zagrebu i naš sviet po novinah, i sam se stavio sa nekoliko odličnih rodoljuba, da pokušaji utre put ozbiljnomu izkapanju (V. Viestnik hrv. arkeol. društva br. I. str. 15 tek. god.) Na njegov poziv pohiti namah u Bakar muz. ravnatelj, i u malo dana napornoga rada postignu uprav nenadani uspjeh. Arkeologički predmeti uslied toga ravnateljeva izleta hrv. arkeolog. muzeju pribavljeni bjahu tako sjajni i po znanost važni, da su si privukli pozornost i nekijh članova našega zem. sabora, koj uz vladinu naklonost blagoizvoli doznačiti 300 for. zato, da se započeta izkapanja još ove godine u Bakru nastave.

U tu svrhu isti muz. ravnatelj početkom lipnja odputi se preko Rieke u Bakar. Radnja, koja nije više trajala od 15 dana, uzplodila je tako sjajno, da je svaku nadu daleko nadmašila. Obilna žetva toga izkapanja došla je već u Zagreb u četiri velika sanduka uz osam kamenitih ogromnih žara, te se sada čisti i popravlja. Glavni predmeti jesu: šest komada od zlata (naime jedan došta težki prsten sa krasno urezanom granatom predstavljajućom žensko poprsje, još jedan prsten s kamenom a jedan bez kamena, dvie naušnice i jedan broš *a filigrana*); više prstena od srebra, bakra i željeza; prsten od jantara, na kom stoji uznosito položeno poprsje žensko s vlasi iznad glave na debeli obluk kao diadem priredjenimi te nazad povučeni i složenimi na način čunja, a sve tako točno i viešto izvedeno, da mu se uprav diviti moraš; posuda od bronza, na kojoj sve naokolo u rilifu vidi se medju stabli paš u trku za jelenom, pred kim trči u propanj tigar, a pred ovim bik; na poklopcu mu pako, koj se zaponcem otvara, glava satira, te s provrslom o boku pregljicami utvrđenim; krasan kosteni *balsamarium*; drvena zavjetna ruka držeća sa prva tri pružena prsta voće; dvie metalne žlice osobite vrsti a jedna od kosti; zatim raznoga načina i obsega sjaset staklenih boca, časa, zdjela i tanjura, a isto tako i od pečenice. te do metar dugih zemljenih žara, oko pedeset svetiljka dragostnimi slikami i raznimi nadpisi ukraseni a svaka mal ne svojim obulusom providjena, jegala i bočka i drugih svakojakih predmeta od stakla, kosti i bakra, tegla ogromnih sa različitim nadpisi itd. Točan opis i popis doći će u svoje vrieme na svietlo u ovom Viestniku hrv. arkeolog. društva sa slikami na tablah, koje se već sada izradjuju.

U tom napornom radu pomagali su ravnatelju osobitom požrtvovnosti i vieštinom gospoda kotar. sudac Vladoje Vodvaržka, prof. Luka Roić, Dr. Ivan Benzan, Jakov Batistić ljekarnik, prof. Narcis Damin navlastito risanjem raznih položina, Artur Dujmović, Ivan Bonetić, Damian Andrianić i Franjo Penko, a skoro i sav grad je pratio velikom zanimivosti i zadovoljstvom nenadane uspjehe, kojim se svim ovdje svečano u ime hrv. nar. muzeja izriče najtoplija hvala.

Ali i u nas jedva da što uspije bez vražjega popečka. Njeki zagorac Tomo Lukanović, ondješni poreznik, dne 13 lipnja, notabene po podne, stavi predlog u sjednici gradskoga vieća, u koje se proturao bog zna kako, jamačno proti volji gradjana, koji ga već davno i javno od srdeca mrze: pošto se izkopine na gradskom trgu smatrati moraju kao gradska imovina, neka se stavi o bok muzealnomu ravnatelju gradski odbor, koj će voditi kontrolu o svem, što bi se izkopalo; neka se javna izložba priredi od svega, a samo zatim neka se sbirka *daruje* zem. muzeju. Proti toj odveć krupnoj bedastoći usta prvi tu prisutan veliki župan, te prezirom odbivši predlog i opisav ravnatelja, reče i to, da je ovaj u svom poslu sasvim samostalan; da je gradu dapače prva dužnost olakotiti mu trud u koliko može, pošto se radi poglavito o razjasnjenju njegove prošlosti; a da se podmeti, čim su javno izkopani, po samih bakarskih suradnicih prenašaju i izlažu u radionici grads. ljekarnika Batistića, gdje jih može svak viditi i popisati kad mu volja. Isto se tako izraze gg. Stjepan Stiglic i Erman Golubović, te jadni moj Tomo jednoglasno propa.

Dalja izkapanja na onom trgu za sada su nemoguća. Tako zvani gradski trg sav je izrovan bio i potražen. Grobište je zauzimalo njegov zapadni dio, te se pruža i dalje k zapadu, gdje se dižu kuće, do kojih se sve razkopalo. Ovomu je i to nepobitni dokaz, što se neki ondješnji gradjani dobro sjećaju, da je mnoga starina izkopana i uništena, kad su se temelji onim kućam postavljali.

Izkopine bakarske, koje zasjecaju u Augustovo doba, te se protežu po prilici do polovice drugoga stoljeća, kako to bjelodano posviedočavaju novci mal da ne u svakom grobu na svietiljkah našasti, sastavljati će u hrv. arkeolog. muzeju osobitu skupinu, kao što već davno sastavljaju i sisačke starine. To one zaslužuju i po važnosti njihovoj i po množini.

Ima u našoj zemlji osim Siska, Bakra, Mitrovice i Osieka još mnogo mjesta, gdje se krije neproračunivo blago arkeologičko, i do koga bi se moglo doći, kao u ovom slučaju, dotično neznatnim troškom. Jedno, koje se već dobro po vele važnih predmetih izkazalo, akoprem do sada navlaš nedotaknuto, jest položaj stare Basiane ležeće medju Putinci i Dobrinci nedaleko od Rume. Ne samo muz. ravnatelj nego i vrli rumski podžupan Budisavljević od duga nastoje, da se nadju sredstva za izkapanje na onom klasičnom tlu, koje po koliko se iz izvanjskih znakova nagoviešćati daje, moglo bi biti naš *Pompei*. Uspjeh bakarski neka povede sadašnju našu Vis. Vladu i Vis. Sabor, da u sastavljenju proračuna za g. 1882 i na Basianu pomisle, koja bi jim bezdvojbeno viečni spomen osigurala na polju znanosti i umjetnosti utemeljenjem navlastito nove basianske sbirke u nar. muzeju.

VIESTNIK

HRVATSKOGA
ARKEOLOGIČKOGA DRUŽTVA.

957

Arkeologičko izkapanje u Bakru.

Na tako zvanom trgu, ležećem na istočnoj strani Bakra uz Luizinsku cestu, kolovoza prošle godine 1880. pod konjskim kopitom, kako nas namah obavijesti veleuč. g. Dr. Fr. Pilepić (*V. Viestnik 1881. str. 15*), propala se ponješto zemlja, a u tom prolomu bje opazen starodavni criep. Pilepić stavi se on čas, da izpita dalje ono zemljište, te naidje najprije na staru grobnicu ciglom obzidanu, zatim na okostnicu prosto ukopanu, te napokon na žare i druge arkeologičke predmete. Taj srećni početak povede ravnatelja nar. muzeja, da sam pohiti u Bakar, i da se razmakom toga pokusa uvjeri o pravom stanju stvari. Urodivši ova radnja uprav nenadanim plodom, te osvjedočivši se podpunoma isti ravnatelj, da se tu radi o prostranom grobištu iz najstarijega rimskoga doba u naših stranah, te da se bez dvojbe u njem skriva veliko arkeologičko blago, koje bi moglo znanstveno i materijalno podignuti važnost i cieniu nar. muzeja, zamoli Zem. Vladu i Sabor, neka obzirom na slabost muz. dotacije dozvole izvanrednu pripomoć za izkapanje u Bakru. Vlada i Sabor rado dozvoliše u to ime 300 for., te se tom svotom prošloga lipnja 1881. oto izkapanje nastavilo.

Ta bakarska poljana, na kojoj se je izkapanje izvelo, načina je prave pačetvorine. Duga je po prilici od zapada prama iztoku 100 metara, a od sjevera prama podnevu 40. Zemljište nije ravno, dali se od podneva prama sjeveru postupno diže, tako da izgleda kao položina. Tomu je uzrok većim djelom naravni sastav bakarske kotline, jer obronci bakarskih bregova sve naokolo postupno slaze do mora. Podnevni pako dio te poljane nješto se ipak vremenom otanjio, jer tuda prolazi Luizinska cesta, tu sustaju obično teretna kola, i neki vele i to, da se je odatle uzelo dosta zemlje za sadašnje groblje. Ono potvrđuje i položaj otkritih starina, koje su

10.032



1964

prama sjeveru sve dublje ležale. Arheologičko zemljište nije hvalalo ni osmi dio te poljane. Ovo je obuzimalo samo podnevno-zapadni kut pačetvorine. God. 1880. razkopalo se ne više od 40 četvornih metara, a prošloga lipnja do 200, naime ona čest, na kojoj se rimsko groblje nalazilo. Pokušaji, koji su se amo tamo izveli po ostalom prostoru i dalje, ostali su sasvim jalovi. Ali treba opaziti i to, da zapadnu stranu te poljane ograničuje duga i podosta prostrana kuća, i da se je više grobova našlo uz sami njen temelj; te se pripovjeda i to, da se je, u što su se temelji te kuće gradili, razkopalo više grobova te povadilo ne malo žara i svakojakih starinskih predmeta razdanih ili uništenih. Groblje se je dakle jamučno steralo još dalje prama zapadu, te izpod one kuće još se čuva bezdvojbeno dosta arheologičkoga blaga, a vjerojatno i boljega, pošto se opazilo, da što se više izkapanjem kući približavalo, to su i našasti predmeti plemenitiji bili. Srećom vlasnik je one kuće društvo odličnih ondješnjih građana, te je temeljita nada, da će ovo nastaviti radnju izpod kuće sebi na čast, znanosti i muzeju na uhar.

Na Tab. I. dajemo sliku izkapanja od prošloga lipnja, kako nam ju blagodarno sastavio na licu mjesta vrli naš prijatelj gosp. prof. Narcis Damin. Pod A nalazi se zemljište po nas razkopano, te kako su nutarnji diobni zidovi tekli. Tu svaki metar = 1 cm. U pet drugih nacerta na istoj tabli a. b. c. d. e. navode se u pomnoženom obsegu pojedini bolje sačuvani grobovi. Ovi su sastavljeni bili od ogromnih cigla (dug. 0·60, šir. 0·46, deb. 0·3) s obodom (vis. 0·3) samo na poduljih stranah. Ove cigle s jedne te strane su na uglovih izpod oboda umjetno a nakoso odbite, a s druge obod nedosiže kraja (Tab. I. f).

Oblik grobova veoma je različit. Ima takovih, koji su sastavljeni od četiri cigle osovno položene a po stranah spojene na pravi kut kao pakočka; pokriti su pako sa dvie druge nakoso sdružene (Tab III. br. 47) ili jednom razito postavljenom, a na dnu kadkada još jedna cigla ili gola zemlja. Njeki su pako do i na tri rake zajedno spojene sastavljeni. Ovi imaju izvana po duljini tri cigle, a po širini izvana i u nutri dvie, sve pako po svojih obodih podosta dobro svezane u jedno tielo (Tab. III. br. 48. 49). U ovih pokrov nije se našao na svom mjestu, pošto gornje cigle, nadstojećom težinom smreskane, ležale su u komadnih nagomilato i van mjesta. Vjerojatno, da su i tu na kut postavljene bile kao na

grobu Tab. I. a¹). Treća znatnija vrst grobova bjaše ona, koju nam predstavljaju grobovi na Tab. I. pod b. c. d. e. Ovdje po jedna ili po dvie cigle, uzporedno položene s jedne i druge strane, stoje bridom naslonjene jedna na drugu na pravi kut, te na način krova; otvorene strane začepane su pako isto ciglom poprečke položenom, s dolnje napokon strane gola zemlja. Mal ne u svih grobovih uglovi, gdje su se cigle spajale, da se zaprieči proticanje vode u nutrašnjost, bili su duljinom i širinom pokriti sa criepovi (Tab. III. 46).

Predmeti nadjeni su u grobovih i izvana do njih. Odkrilo se je mnogo velikih žara kamenitih i zemljenih i u grobovih i do njih i na samu. U tih žarah čuvale su se obično kosti izgorielih tjelesa, a vele često iznad njih i medju njimi našli su se razni predmeti kao posude staklene i zemljene, jegle kostene i bakrene itd., dapače i dvie dragocienosti, koje ćemo dalje opisati. Ali su se predmeti ve-

¹) Ova vrst grobova naliči veoma na one grobove, koji, razsijani po Dalmaciji, Hercegovini i Bosni, naš narod zove steći, a nesmatra obično za svoje. Spodoba je na način kuće, samo steći su od krupnog kamena, ovi od cigla i šuplji. Da su se oni od ovih razvili?

činom ipak nahodili vani do žarah u nalegloj zemlji, a i same dragocienosti, te toga radi u velikom broju već razmrveni ili jako ozledjeni. Gdje nije bilo groba, ondje se kadkada naišlo na skup zemljenih žara razne veličine, te u jednoj od njih bile bi izgoriele kosti, a u drugih povećih ne malo staklenka i pomanjih posuda a i drugih predmeta.

Nije moguće ustanoviti dublinu za pojedini grob radi osobitoga stanja, u kom se vremenom ono zemljište nalazilo, kako smo gori opazili. Što više k brdu, to dublje su i grobovi ležali, te otkrilo jih se i na polovicu i na metar dubljine i više. Našle su se i dvie ukopane okostnice, glavom na pram iztoku, bez predmeta na i do njih, ali ipak iznad grobova, mal ne uz površje zemljišta. Valjda jih i više bilo, ali se vremenom uništile. Ove dvie jedini su svjedoci pokapanja tjelesa na ovom groblju, te je bez dvojbe da spadaju na kasnije vrijeme. (Tab. I. 9.)

Doba bakarskoga grobišta rimskoga očividno nam pokazuju novci, koji su redovito našasti bili u koritu zemljenih svietiljka do ili u žarah ponamješćenih, kadkada i po više njih u istom grobu, valjda po broju izgorielih tjelesa tu spravljenih. Mi smo te novce, u koliko su čitljivi bili, naveli uz svieće, na kojih su na-

djeni, te spadaju na Nerona, Trajana, Adriana, Antonina, i Faustinu stariju (od god. 54 do god. 161 po Is.)

Predmeti, u Bakru otkriti, stoje u tiesnom odnošaju s onimi, koji su našasti bili i drugdje uzduž obale našega primorja; ali se postupno sve više udaljuju od onih, koji se ondje podalje na kopnu izkapaju. Mi smo god. 1873. pripomoću preč. g. župnika M. Juretića i načelnika g. A. Durbešića kopali na nekoliko dana u mjestu nazvanu *Grobište*, mala brdovita dolina južno od Grobnika na puškomet. Akoprem smo tu našli koju svietiljku i mjedenku, koje su istoga načina kao one u Bakru, značaj groblja sasvim je različit. U *Grobištu* ni traga nutarnjim ni ma kojim zidinam ili grobovom od ogromnih cigla na način bakarskih, a ni žaram kamenitim ili zemljenim čisto rimske radnje, te tako nema ni izgorielih tjelesa. Ondje čovječje okostnice uredno su se otkrivale u mulju po prilici pol metra duboko, kamenjem samo i na prosto ogradjene; predmeti pako, navlastito zemljeni, bili su posla i načina krupnijega. Karakteristično je i to, što se je na Grobniku sjaset puceta svake veličine na način kapica izkopalo, dočim se u Bakru nijedan takav nepomoli. Nadalje ovogodišnja sjajna i prebogata izkapanja, obavljena g. M. Markovićem u Prozoru, koja će do mala u ovom listu bjeli sviet ugledati, izdala su sjaset predmeta, od kojih baš ni jedan nestoji u odnošaju sa bakarskimi, dočim se slažu podpunoma sa predmeti, koji se već od prije nalaze u zem. muzeju, a potiču iz raznih mjesta naše gornje krajine.

S druge strane bakarskim sasvim su srodni predmeti oko g. 1850. izkopani na Rieci u mjestu nazvanu *Braida* (vrt Haire). Tu je nadjeno više kamenitih i zemljenih žara, cigla, staklenka, zem. posuda, bodača, ogledala itd. i rimskih novaca, mal ne sve kašnje u Peštu odneseno za sukromnu sbirku, te valjda već uništeno. Samo nekoliko predmeta dobrotom gosp. gradskoga načelnika vit. Ciotta pregledali smo u sbirci, koju isti od nekada revno sakuplja za budući gradski muzej. Isto tako bakarskim srodni su predmeti otkriti prošlih godina u sv. Jakovu nedaleko od Kraljevice na rtu nazvanu Havišće. Tu se izkopalo ne malo kamenitih žara, zemljenih posuda i svietiljka, staklenka, prstena od jantara, srebra i željeza, mjedenih okruga srebrom okovanih, rimskih novaca itd., te nješto od toga čuva se u zem. muzeju darom ondješnjega domoljuba župnika Pavla Šegulje. Tu smo i mi na prolazku iz Vinodola na Rieku g. 1874. pokušali, da za trenutak barem izpitamo ono zemljište,

te naidjošmo namah na kamenitu žaru, u kojoj samo izgoriele kosti, a do nje rimski bakreni novac veoma iztrošen, no po liku bez dvojbe iz druge polovice prvoga stoljeća po Is. Tako se reći može o sv. Jurju kod Senja, tom samo razlikom, da ovdje uz predmete rimskoga načina kao u Bakru dolaze kadkada na vidik i predmeti sasvim drugoga kao na Grobniku, kalupa naime od onih u Prozoru. Zem. muzej dobio je nekoliko stvari tu izkopanih od g. Fr. Sabljaka onda prijemnika u tom mjestu; a po obećanju očekujemo od ondješnjega rodoljuba župnika Biankinia još više. Četvrt sata od Vrbnika na Krku kod crkve sv. Mavra u Ljupoljici izkopalo se je tu nedavno, kako smo ondje obaviešćeni bili, ne malo grobova od velikih cigla sastavljenih, te u i okolo njih žara, staklenka, svietiljka i drugih predmeta iste vrsti, kao što su bakarski. U Osoru izkapanjem ondješnjega župnika preč. Bolmarčića došlo je na svietlo sjaset predmeta, koji stoje u najtjesnijem odnošaju po načinu i radnji s bakarskimi, tom razlikom, da i ondje kao što u Grobniku i u sv. Jurju bjaše i drugih, koji zasiecaju u još starija doba (V. *Ausgrabungen in Oszero v. Benndorf. Archeol. — epigr. Mittheil. aus Oesterr. Jahrg. 1880 p. 73*). Napokon spomenut nam je i to, da se je ne malo bakarskim sasvim sličnih grobova i predmeta otkrilo g. 1836. u Ljubljani u kapucinskom vrtu, i da se ta sličnost navlastito u staklenkah iztaknuje (*Sitzungsberichte der phil.-hist. Classe der Akad. d. Wissenschaft. VI. Bd. Wien 1851 p. 207 sqq. Archaeol. Analecten v. Jos. Arneht. Taf. XII*).

Groblje bakarsko jasnim je dokazom, da se je ondje tečajem prvoga stoljeća po Is. dizalo dosta važno mjesto. Do sada nije bilo za to dostatnoga temelja, akoprem se na to mislilo na podlogi jednog sarkofaga, komu sada nema traga, i nekoliko rimskih novaca, o kojih se nezna, gdje se čuvaju. O nadpisih rimskoga doba ni spomena, a kamo li, da bi nam ovi odgonetali, kako se ovo mjesto onda zvalo. Barčić u svom rukopisu o Bakru veli, da mu ime *Volcera*, po drugih pako bila bi to *Raparia*. Da vidimo što bi se o tom po starih piscih nagadjati dalo.

Zapadnu obalu našega primorja od Raše do Senja prvi nam opisao *Ptolemaeus* (*Geographia, ed. Wilberg p. 166*). Po njem primorski gradovi ležali su ondje ovako:

Alvona (Ἀλούωνα)	36° 50'	45°
Flanona (Φλανώνα)	37°	44° 50'
Tarsatica (Ταρσατίαια)	37° 40'	44° 45'

Oenei fluvii ostia (Οινέως ποταμοῦ ἐκβολαί)	38°	44° 45'
Volcera (Ούόλκερα)	38° 30'	44° 45'
Senia (Σένια)	39° 15'	44° 40'

Putopis *Antoninianski* (str. 130) bilježi:

Ad Titulos	Ad Turres XX
Tharsatico XVII	Senia XX

Peutingerska Tabla, koja ertom označuje dva puta od *Tarsatike* do Senja, obalni bez oznake daljine a medjutimnim mjestom *ad Turres* i medjuzemni sa oznakom XX. mp., ima:

Arsia	Ad Turres
Alvona XII	Senia XX
Tarsatica XX	

Ravennatis Cosmographia na str. 224 i 381 navodi bez oznake daljine:

Senia	Tharsaticum
Turres	Lauriana
Raparia	Albona

Dakle po Antoninianskom putopisu *Ad Turres* imalo je ležati blizu Cirkvenice, pošto po istom putopisu, a valjda i po Peutingerskoj tabli isto daleko bjaše od *Tarsatica* kao i od *Senia*, XX mp. Po Ravenatu medju *Ad Turres* i *Tharsaticum* stajala je jošte i *Raparia*, koju isto u toj strani spominje Guido (*Geographica* p. 543). Na obali, koja se pruža od Cirkvenice do Rieke, nije se do danas otkrilo dovoljnih tragova za rimsko selište osim u sv. Jakovu i u Bakru, te je *Raparia* tu mogla biti. Čini se, da i Ptolemaeus, sudeć po navedenimi mjerami, približuje svoju *Volcera* više k gradu *Tarsatica* nego li k gradu *Senia*. Na istoj širini (*latitudo*) stavlja *Tarsatica*, *Oenei fluvii ostia* i *Volcera* t. j. na 44° 45 od ekvatora. Glede duljine (*longitudo*), t. j. dalečine od meridiana, ova je razna dakako, pošto se od Rieke obala našega primorja giblje ako i postupno no ipak znatno k istoku, te tim razlika brzo skače.

Uz sve te vjesti nije ipak moguće opredjeliti za stalno ime Bakru za rimsko doba. Toga radi, kako smo gori opazili, treba čekati, da nam ga koj nadpis otkrije. Uzimamo si ipak slobodu očitovati naše mnijenje u toj stvari. U koliko znamo nije se do danas u Trsatu našlo takovih starina a niti nam neostaju ondje tragovi starodavnih sgradjevina, po kojih bi se i samo naslutiti dalo, da je ondje negda ležalo znatno mjesto, naime rimska *Tar-*

satica. Trebalo bi dakle dobro potražiti visočine ležeće medju Riekom i Bakrom, te vidjeti, nekriju li one još sada ostanke onoga grada. U Kostreni našlo se je i žara i starih novaca i drugih starinskih predmeta, a nješto i po Dragi do sv. Kuzme. Nadju li se ti ostanci, onda po nas luka bakarska nebi drugo bila van stovarište stare *Tarsatica*, a rieka *Oeneus* bakarski zaljev. Stari zemljopisci uzeli su i kotorski zaljev za prostu riekku.

Ostaje nam da donesemo točan popis predmeta u Bakru izkopanih. U tom popisu stegnuli smo se ipak samo na nuždne njihove oznake, a da ljubitelju starina taj popis bude jasniji, na Tab. II. III. i IV. predočujemo mu nacрте od boljih te karakteričnijih predmeta.

I. Dragocienosti.

1. Prsten od jantara ukrasen sa nad njim ležećim poprsjem mlade žene u punom propupu. Vlasi se dižu nad glavom na način vienca, te se zada spuščaju na dugo, i skupljaju se napokon u snop. Sve je pako uprav osobitom većinom izraženo. Teži 1.82 gr. Tab. IV. br. 33.

2. Prsten od suhoga zlata, pakrugastog oblika, sa kamenčićem (*Granata*), na kom je veoma vješto urezano žensko poprsje. Na glavi kao da su dva rožičića, a medju njimi krugljica, a to bila bi Isis, o kojoj piše K. O. Müller (*Handbuch der Archaeol.* 1878. 285): *Isis, menschlich, mit Kuhhörnern und einem Discus dazwischen, oft schwer von Athor (Ἀφροδίτη) zu unterscheiden*. Teži 7.17. Tab. IV. br. 42. a. b.

3. Prsten od suhoga zlata, pakrugastog oblika. Izgleda kao krupan, ali je šupalj, te izpunjen nekom caklenom tvari. Kamenčić obao, modrast, bez ureza, opao je. Teži 1.68. Tab. IV. br. 38.

4. Prsten, od plosnate dosta debele zlatne žice, pakrugastog oblika, bez ukrasa i glavice. Teži 1.60.

5. Dvie istovjetne mindjuše od oble zlatne žice. Jedan okrajak svršuje na krugić, na kom rupica, kroz koju je provučen te zavojen šiljak drugoga okrajka. Jedna teži 0.65, druga 0.68. Tab. IV. br. 43.

6. Dvie zlatne stvarce, jedna od plosnate a druga od oble žice, zajedno spojene tako da jedna visi o drugoj. Prva je četverokutna a druga djelomice okrugljasta, kao da je to privjesak od mindjuše. Teže 0.27.

7. Privjesak od niza (broš) zlatan, ploč, okrugljastog oblika, samo s dolnje strane na obluk, iz koga padaju tri privješčića. S preda je ploča nakićena žičevinom (a filigrana). Gori ušica dosta velika. Teži 1.66. Tab. IV. br. 44.

II. Predmeti od raznih kovina.

1. Posuda od bronza, okrugljasta, sa postavkom, poklopcem i dva uha, u kojih je provrslo zabodeno. Sred poklopca, koj je zaponcem utvrđen, glava satira. Naokolo trbuha u propupu četiri živine trče jedna za drugom u propanj. Stablo djeli jednu od druge. Prva je bik, druga tigar, treća

jelen, četvrta pas. Vis. sa podignutim provrsлом 0·17, a sama posuda 0·10. Promjer najveći na trbuhu 0·10¹/₂, na ušću i postavku 0·6. Tab. IV. br. 52.

2. Posuda bakrena, liepe zelene boje i uprav savršena lika, sa dvie krasne ručke. Vis. 0·19¹/₂, promjer na ušću 0·6, najveći 0·11. Tab. II. br. 26. Tab. III. br. 2.

3. Ogledalo okruglo od bronza. Uz rub s preda urezane zubate crtice, a zatim dva okruga; zada dva okruga uz rub a četiri do sriede. Razpolovljen i hrdja ga veoma pokvarila. Promjer 0·8³/₄. Tab. II. br. 2. a. b.

4. Isto kao br. 3. Zelenom mazom tvrdo pokrit, te se ukrasi nevide. U komadih. Promjer 0·9.

5. Isto kao br. 3, nego četverouglast, isto zelenom mazom obložen. U komadih. Dugo s jedne strane 0·10, s druge 0·11¹/₂.

6. Bodača bakr. na sukrst, bez brka. Duga ovako 0·10. Tab. II. br. 3.

7. Kao br. 6. ali ne na sukrst. Na polovici čvor za ukras. Bez brka. Duga ovako 0·9. Tab. III. br. 5.

8. Kao br. 7. Glavica joj plosnata, okrugla, stoji nakoso. Duga 0·10³/₄. Tab. II. br. 4. Još 7 ovakovih razne veličine i nješto komada.

9. Mindjuše sa privjesci, iz srebra. Tri para raznoga oblika a proste radnje. Tab. III. br. 1. 8.

10. Prstena srebrna dva iz žice s plosnatim okom od iste tvari, na kom je grančica urezana. Četiri takova bakrena bez grančice, a dva bez glave i nesvezana. Tab. II. br. 21. 22. 23.

11. Dva odlomka prstena od željeza sa stjenami, sve izkvareno.

12. Amalija srebrna, sastavljena od oble debele žice, do koje po sriedi dva kruga, jedan uz drugi, naime po jedan sa svake strane. Pri krajevih podrezan (dvostruki *phallus*). Teži 1·0. Tab. IV. br. 46.

13. Klestica bakrena polomljena. Duga 0·6³/₄. Tab. III. br. 28. Još jedna ciela, u kojih se ručka neuzvija na okrug a i tanja je nego su štipala.

14. Zapijača bakrena, na luk, sa zavojci zada poprječno. Duga 0·6. Tab. IV. br. 49.

15. Udica bakrena. Duga 0·3.

16. Velika jegla srebrna, u dva komada. Duga 0·15.

17. Poklopac bakren od posudice u spodobi pasje glave. Još jedan mali prosti.

18. Dva ključa bakrena, jedan ravan, drugi glavom popriečno. Tab. IV. br. 40. 41.

19. Ploče bakrene okrugljaste od brava sa čavličići, dvie zavornjače od istih, i mnogo komada od bakrene skrinje. Tab. III. br. 40.

20. Mirisar mjeden, valjast, sa čunjastim poklopcem, krugljom na vrhu. Vis. 0·8¹/₂, promjer 0·4. Tab. III. br. 30.

21. Njetilo bakreno, s jedne strane oblo kao ručka a s druge plosnato za vadjenje pomasti iz mirisara i razvoditi jih. Dugo 0·16. Tab. IV. br. 45.

22. Žličica bakrena, sastavljena od oble palice, koja s jedne strane svršuje šiljasto a s druge nosi malu okruglu pliticu. Duga 0·16, promjer 0·2³/₄. Tab. IV. br. 32.

23. Velika žlica bakrena, dugačka i plitkasta, sa čvornastom ručkom osobitoga načina. Sve dugo 0·15¹/₂. Tab. IV. br. 50.

24. Razne spona i veružice bakrene sa karikami. Tab. III. br. 3. 7. 21. 41. 42. 43. 50.

25. Čavli, klinčići i žice bakrene. Još više željeznih.

26. Tri pločasta komada olovna, u dva su čavličići zabodeni, valjda ostanci skrinje.

Predmeti od kosti i od drva.

1. Ruka zavjetna do lakta od drva (V. Viest. 1879. str. 107). Sa tri prva prsta pridržava kosticu od vojke, zadnja dva unutra su pognuta. U drvo izada zaboden je plosnati željezni čavao, a tu je manjkava. Radnja je prilično dobra. Duga 0·9¹/₂. Tab. IV. br. 35.

2. Mirisar košten, valjast, veoma liepo izdijelan. Na poklopcu ručka fali. Vis. $0\cdot5\frac{1}{2}$, promjer $0\cdot3\frac{1}{2}$. Tab. IV. br. 47. a. b. V. gori br. 20.

3. Probušena valjasta kost kao ručka, okrugli nakićena, ali nepotpuna. Ovako duga $0\cdot8$. Tab. II. br. 5.

4. Obla, svudi isto debela palica, u dva istovjetna komada razstavljena, tako da jedan u drugi ulazi, ali je jedan od njih dužinom razpodeljen. Glava jednog komada pri sdruženju obložena je srebrnom (?) pločom. Duga $0\cdot14\frac{3}{4}$, promjer $0\cdot3\frac{1}{4}$. Tab. III. br. 9.

5. Žlica od kosti plitkasta a dugačka. Manjka dio ručice. Korito dugo $0\cdot7\frac{1}{2}$, široko najviše $0\cdot3\frac{1}{2}$. Tab. IV. br. 37.

6. Bodača sa glavicom na četiri kvрге. Duga $0\cdot16\frac{3}{4}$. Tab. II. br. 6. Uz ovu još drugih šest razne veličine i načina. Tab. III. br. 6.10.

7. Jegle s ušicom razne veličine. Sedam komada i još više komadića. Tab. IV. br. 51.

S. L.

IV. Staklenke.

A. Zdjele.

1. Zdjela viencem razpruženim i podstavkom visokim $0\cdot2$. Izvana, gdje viencem počima, sve naokolo užica, koja se iznutra prikazuje kao dvostruka okrugla crta. Dno kao da je jaružicom odciepljeno. Sliepljena i ponješto manjkava. Promjer $0\cdot28$, vis. $0\cdot8$. Tab. IV. br. 1.

2. Kao br. 1, nego pomanja. Sliepljena i ponješto manjkava. Promjer $0\cdot19\frac{1}{2}$, vis. $0\cdot7\frac{1}{2}$. V. *Archaeol. Analecten v. J. Arneht. Tafeln zu dem Sitzungsberichte der philos. hist. Classe. Wien 1851 Bd. VI. Heft 1. 2. Taf. XII. b.*)

3. Kao br. 1, nego dno čunjasto i znakom valjda tvornice providjeno, a na viencu naokolo malene erte popriečno položene. Promjer $0\cdot15\frac{1}{2}$, vis. $0\cdot5\frac{1}{2}$.

4. Kao br. 3, nego na viencu neima poprečnih crtica ni znaka na dnu. Promjer $0\cdot15$, vis. $0\cdot5$.

5. Kao br. 4. Promjer $0\cdot15\frac{1}{4}$, vis. $0\cdot5\frac{1}{2}$.

6. Kao br. 4. Potresom razbita, te nješto manjka. Promjer $0\cdot14$, vis. $0\cdot4\frac{1}{2}$,

7. Kao br. 4, nego na viencu pridružena dva zubata lučića od iste tvari, jedan prama drugomu. Potresom oštećena, te nješto manjka. Promjer $0\cdot13$, vis. $0\cdot4\frac{1}{2}$. Tab. II. br. 14.

B. Tanjuri.

1. Tanjur veliki, prostranim i na okrajku malco povinutim viencem, a niskim podstavkom. Dno iznutri čunjasto. Sliepljen i manjkav. Promjer $0\cdot30$, vis. $0\cdot4$. Tab. IV. br. 2.

2. Kao br. 1, nego mu na viencu dva zubata lučića kao na zdjeli br. 7. Sliepljen i manjkav. Promjer $0\cdot20\frac{1}{2}$, vis. $0\cdot3$ do 4 .

3. Kao br. 1. Promjer $0\cdot16$, vis. $0\cdot2\frac{1}{2}$.

4. Kao br. 1, nego na viencu crtica popriečno kao na zdjeli br. 3. Sliepljen i manjkav. Promjer $0\cdot17$, vis. $0\cdot3$.

5. Kao br. 4. Samo odlomci.

6. Kao br. 1, ali je deblje tvari. Okrnjen i sliepljen. Promjer $0\cdot15\frac{3}{4}$, vis. $0\cdot2\frac{1}{2}$.

7. Kao br. 1. Ponješto sliepljen. Promjer $0\cdot15$, vis. $0\cdot3$.

8. Kao br. 1. Samo odlomci. Promjer $0\cdot17$, vis. $0\cdot2$.

9. Kao br. 1, nego se viencem diže izravno, nema podstavka, a modrozagasene je boje. Promjer $0\cdot18\frac{1}{2}$, vis. $0\cdot2\frac{1}{3}$. Tab. II. br. 10.

10. Tanjur oblast na način kopanjice, bez podstavka. U dvostrukom okrugu, popriečnimi crtami ukrasenu, nacrtane su dvie ribe a četiri naokolo izpod vienca. Promjer $0\cdot21$, vis. $0\cdot4\frac{1}{4}$. Tab. II. br. 1.

11. Kao br. 9, nego s podstavkom, a biele je obične boje. Promjer $0\cdot21$, vis. $0\cdot4\frac{1}{4}$. Tab. IV. br. 4.

12. Kao br. 11, nego podeblje tvari. Promjer $0\cdot16\frac{3}{4}$, vis. $0\cdot3\frac{3}{4}$.

13. Kao br. 11, nego dvostrukim kolutićem na dnu izvana mjesto podstavka, iznutra pako dvostruka jaružica. Potresom potrt te sliepljen i manjkav. Promjer $0\cdot17\frac{1}{2}$, vis. $0\cdot2\frac{3}{4}$. Tab. II. br. 8.

14. Kao br. 11, nego jedva trag viencu. Promjer $0\cdot13$, vis. $0\cdot1\frac{1}{2}$.

15. Kao br. 11, ali bez vienca, te sasvim ravan. Promjer $0\cdot11\frac{1}{2}$, vis. $0\cdot1\frac{3}{4}$. Tab. IV. br. 16.

C. Čaše.

1. Čaša na šest ugiba osnovno položenih, te se prikazuje kao okrugasto-valovita, bez podstavka. Vienac jedva vani zavojen. Potrta za trešnje, te na viencu i sa strane ponješto manjkava. Promjer na otvoru $0\cdot6\frac{3}{4}$, vis. 0·9. Tab. II. br. 9. — Slična u Spljetskom muzeju iz Dalmacije, a isto takova našasta kod Ljubljane (*V. Archaeol. Analecten l. c. Taf. XII. n. 6.*)

2. Čaša na četiri ugiba kao pod br. 1, te četverokutna; ušće od tiela obsežnije. Jedva na viencu okrnjena. Promjer na otvoru $0\cdot8\frac{1}{4}$, vis. 0·9.

3. Čaša čunjastoga načina, sa tri jaružice naokolo izpod vienca, bez podstavka. Na viencu malko okrnjena. Promjer na otvoru $0\cdot7\frac{1}{2}$, vis. $0\cdot11\frac{1}{2}$. Tab. II. br. 20.

4. Čaša sa okrugljastim dnom; vienac dobrano vani zavojen. Promjer na otvoru $0\cdot7\frac{1}{2}$, vis. $0\cdot6\frac{1}{2}$.

5. Čaša na način kaleža, povicokim podstavkom, i viencem od ostalog tiela prostranijim. Izpod vienca više okrugića naokolo. Manjkava. Promjer na otvoru $0\cdot19\frac{1}{2}$, vis. $0\cdot15\frac{1}{2}$. Tab. IV. br. 6.

6. Čaša s podstavkom kao br. 5, ali joj tielo okruglo. Ponješto manjkava i sliepljena. Promjer na otvoru 0·9, vis. $0\cdot11\frac{1}{4}$.

7. Čaša niskim podstavkom; pri polovici širi se na ugao; vienac vani pružen. Promjer na otvoru 0·6, vis. $0\cdot10\frac{1}{2}$.

8. Čaša na četiri ugiba kao br. 2, no ovdje izgledaju kao kopanjice. Vienac od tiela užji, a podstavak malen. Promjer na otvoru $0\cdot6\frac{1}{4}$, vis. 0·9.

9. Čaša na način usječena čunja, niskim podstavkom i okrugićem izpod vienca. Promjer na otvoru 0·6, vis. 0·8. Tab. IV. br. 13.

D. Šalice.

1. Šalica modro-zagasene boje, malenim podstavkom, viencem van pruženim, doli malko užja nego je gori. Dno joj se iznutra diže čunjasto. Mal ne ciela ali sliepljena. Promjer na otvoru $0\cdot11\frac{2}{3}$, vis. 0·6. Tab. II. br. 11.

2. Šalica žuto-tamne boje, malenim podstavkom, na način usječena čunja, viencem van pruženim. Na dnu mal ne ravna. Promjer na otvoru $0\cdot4\frac{1}{2}$, vis. $0\cdot7\frac{1}{2}$.

3. Kao br. 2. sa dva ureza sa strane kao znak, zelenkaste boje. Promjer na otvoru 0·7, vis. 0·4.

4. Kao br. 1, ali je bijela, a vienac joj djelomice uzvinut. Promjer na otvoru 0·8, vis. $0\cdot3\frac{3}{4}$.

E. Boce.

a) Boce sa dvie ručice pri grlu.

1. Boca čunjastoga načina, sa nekoliko dubčastih okrugića naokolo. Promjer na otvoru $0\cdot8\frac{1}{2}$, najveći 0·17, na dnu $0\cdot10\frac{1}{2}$; vis. $0\cdot39\frac{1}{2}$. Tab. II. br. 15.

2. Boca na okrug, žutog tiela a modrih ručica. Izvanredno krasna. Promjer na otvoru 0·2, vis. 0·7. Tab. IV. br. 8.

3. Boca na četiri četvornaste strane, viencem van pruženim. Promjer na otvoru 0·3, vis. $0\cdot9\frac{1}{4}$.

4. Boca na četiri strane po sriedi malko upale. Dizala se u nutri u sried dna jedne mnogo veće boce razkomadane, sastavljajući s ovom jednu cielinu. Veoma riedki pojav umjetnosti. Dočim je ostala tvar boce zelenkasta, ručice su njezine osobite bieloće kao da su od alabastra. Promjer na otvoru $0\cdot2\frac{1}{4}$, vis. 0·8. Tab. IV. br. 3.

b) Boce sa jednom ručicom pri grlu.

1. Boca valjasta, gori malko deblja, zavojenim viencem. Promjer gori 0·12, doli $0\cdot9\frac{1}{2}$, vis. 0·25. Tab. II. br. 16.

2. Boca kao br. 1, osim što je vienac malko obsežniji. Sliepljena i manjkava. Promjer na otvoru $0\cdot7\frac{1}{4}$, na dnu 0·11, vis. $0\cdot24\frac{1}{2}$.

3. Kao br. 2. Sliepljena i manjkava. Promjer na otvoru 0·5, na dnu 0·7, vis. $0\cdot20\frac{1}{2}$.

4. Kao br. 3. Sliepljena i manjkava. Okrugića naokolo izkićena. Promjer na dnu 0·7, vis. do grla 0·12.

5. Kao br. 3, no niža i širja. Promjer na otvoru $0\cdot5\frac{1}{4}$, najveći $0\cdot14$, na dnu $0\cdot11\frac{1}{2}$, vis. $0\cdot13$. Tab. II. br. 12.
6. Kao br. 5, nizzdol malko užja a širjim grlom. Promjer na otvoru $0\cdot8\frac{1}{4}$, najveći $0\cdot10\frac{1}{2}$, na dnu $0\cdot5\frac{1}{2}$, vis. $0\cdot10$. Tab. II. br. 13.
7. Boca čunjastoga načina, velike ručice i oblastoga dna. Promjer na otvoru $0\cdot3\frac{3}{4}$, najveći $0\cdot10\frac{1}{2}$, vis. $0\cdot12$. Tab. II. br. 19. (*V. Archaeol. Analecten l. c. Taf. XII. n. 3. 4.*)
8. Boca okrugastim tielom, visokim podstavkom i grličem. Promjer na otvoru $0\cdot3\frac{3}{4}$, najveći $0\cdot11$, na podstavku $0\cdot6\frac{1}{2}$, vis. $0\cdot14$.
9. Boca na četiri četvornaste strane. Na dnu uz svaku stranu četverokuta izbočito po jedan ulomak nadpisa, piknjami jedan od drugoga razstavljen: ASI·LA·EM·IBI, tako da one četiri piknje dolaze u kutovih. Promjer na otvoru $0\cdot5\frac{1}{2}$, šir. po stranah $0\cdot7\frac{1}{2}$, vis. $0\cdot26$. Tab. II. br. 17. a. b.
10. Boca istoga načina kao br. 9, ali na dnu mjesto nadpisa izbočito osmozračna zvijezda. Promjer na otvoru $0\cdot3\frac{1}{2}$, šir. po stranah $0\cdot6\frac{1}{4}$, vis. $0\cdot18$
11. Kao br. 10, nego na dnu po sriedi piknja a oko nje osam trokuta umjetno položenih. Promjer na otvoru $0\cdot4\frac{1}{2}$, šir. po stranah $0\cdot5$, vis. $0\cdot18$.
12. Kao br. 10, nego na dnu po sriedi tri okruga, a u kutevih po jedan trokut. Na uglu okrnjena. Promjer na otvoru $0\cdot4\frac{1}{2}$, šir. po stranah $0\cdot6\frac{1}{2}$, vis. $0\cdot16$.
13. Kao br. 10, nego na dnu po sriedi nacrt kao guske, a u kutevih po jedna piknja. Promjer na otvoru $0\cdot3\frac{3}{4}$, šir. po stranah $0\cdot6$, vis. $0\cdot16$.
14. Kao br. 10, nego na dnu po sriedi piknja, a u kutevih ukras, koj naliči na σ . $0\cdot16$. Sliepljena. Promjer na otvoru $0\cdot4\frac{1}{4}$, šir. po stranah $0\cdot6\frac{3}{4}$, vis. $0\cdot16$.
15. Kao br. 10, od veoma debela stakla te odveć težka, sa četiri okruga na dnu. Promjer na otvoru $0\cdot4\frac{1}{2}$, šir. po stranah $0\cdot8\frac{1}{2}$, vis. $0\cdot16$ (*V. Archaeol. Analecten l. c. Taf. XII. a.*)
16. Kao br. 10, nego na dnu bez ukrasa. Promjer na otvoru $0\cdot4\frac{1}{2}$, šir. po stranah $0\cdot10$, vis. $0\cdot15$.
17. Kao br. 16. Okrnjena na uglu i sliepljena. Promjer na otvoru $0\cdot3\frac{1}{4}$, šir. po stranah $0\cdot8$, vis. $0\cdot13\frac{1}{2}$.
18. Kao br. 10, nego na dnu po sriedi slika na krst, a u kutevih po jedna piknja. Promjer na otvoru $0\cdot3\frac{1}{2}$, šir. po stranah $0\cdot6$, vis. $0\cdot16$.
19. Nosac boce osobitoga načina. Tab. IV. br. 15.

c) Boce bez ručice.

1. Boca trbušata, obsežnim otvorom, viencem van pruženim. Promjer na otvoru $0\cdot12\frac{1}{4}$, najveći $0\cdot17$, na dnu $0\cdot6$; vis. $0\cdot14$ (*V. Archaeol. Analecten l. c. Taf. XII. n. 1.*)
2. Kao br. 1. Okrnjena na viencu. Promjer na otvoru $0\cdot6\frac{1}{4}$, najveći $0\cdot8$, na dnu $0\cdot5$; vis. $0\cdot6\frac{1}{2}$.

3. Kao br. 1. Manjkava i sliepljena. Promjer na otvoru $0\cdot6$, najveći $0\cdot7$, na dnu $0\cdot4\frac{1}{2}$; vis. $0\cdot6$.
4. Kao br. 1. Manjkava i sliepljena. Promjer na otvoru $0\cdot5\frac{1}{2}$, najveći $0\cdot7\frac{1}{2}$, na dnu $0\cdot4$; vis. $0\cdot7\frac{1}{2}$. Tab. II. 18.
5. Kao br. 1. Promjer na otvoru $0\cdot4\frac{3}{4}$, najveći $0\cdot6$, na dnu $0\cdot3\frac{1}{2}$, vis. $0\cdot5\frac{1}{2}$.
6. Kao br. 1 Promjer u obće $0\cdot4$, vis. $0\cdot3\frac{1}{2}$.
7. Boca okruglastim tielom a grličem upravnim. Promjer najveći $0\cdot9$, vis. $0\cdot12$. Tab. II. br. 25.
8. Kao br. 7, nego grlič i dio tiela manjka. Promjer najveći $0\cdot10\frac{1}{2}$.
9. Boca čunjastoga načina. Promjer najveći $0\cdot9$, vis. $0\cdot15$ (*V. Archaeol. Analecten l. c. Taf. XII. n. 2.*)
10. Kao br. 9, nego grliča nema. Promjer najveći $0\cdot9$.
- 11—56. Boce pomanje, kojim je tielo maleno, čunjasto ili oblasto, no grlo veoma dugačko. Jedna je modраста. Tab. II. br. 27.
57. Suzne bočice stajaće, 22 na broju.
58. Suzne bočice nestajaće, okruglastim dnom, 6 na broju.
59. Boca na četiri četvornaste strane, veoma obsežnim otvorom. Na dnu po sriedi izbočito pet okruga, a u kutevih po jedno slovo, naime u dva ima c i s, u trećem nezna se pravo, jeda li je e ili f, a u četvrtom slika je sasvim nerazumiva. Promjer na otvoru $0\cdot14\frac{1}{2}$, šir. po stranah $0\cdot15$, vis. $0\cdot27$.

60. Kao br. 59. Na dnu ima samo sedam izbočitih okruga. Promjer na otvoru 0·8, šir. po stranah 0·10, vis. 0·12. Tab. II. br. 24.

61. Kao br. 60, ali je doli užja. Ponješto manjkava. Strane po sriedi šir. 0·4, a visoka je do grlića 0·7.

62. Boca sa podstavkom, okruglastog tiela i poduljastog grlića. Promjer na otvoru 0·2, na tielu 0·9, na podstavku $0·5\frac{3}{4}$; vis. 0·15. Tab. IV. br. 10.

63. Boca za liekovnu porabu, uzvita, šiljasta, otvorom s oboje strane (ital. *Ritorta*). Naliči grčkomu $\rho\upsilon\tau\acute{o}\nu$, no ovaj je iz pečenice i jednim otvorom. Promjer na otvoru $0·4\frac{1}{2}$, najveći 0·8; duga je 0·27. Tab. II. br. 7 (*V. Archaeol. Analecten l. c. Taf. XII. n. 8*).

64. Boca oblata. tanahnim grličem i prostranim viencem. Promjer na otvoru 0·3, najveći $0·3\frac{1}{2}$, na dnu 0·2; vis. $0·10\frac{1}{2}$. Tab. IV. br. 5.

65. Boca na osam četvornastih stranah, dugim a tanahnim grličem (vis 0·9). Promjer na otvoru $0·2\frac{1}{2}$, na dnu 0·3; vis. $0·14\frac{1}{2}$. Tab. IV. br. 7.

66—68. Razni komadi od potrtih boca.

69. Modrasta zrna i komadi staklenog tiesta

F. Igle.

1. Pribadača, gori i doli zavita na konopac, po sriedi na četiri četvornaste strane, glavicom uvitom na s, osobito liepa. Duga $0·17\frac{3}{4}$. Tab. IV. br. 14.

2. Pribadača bez rta, zelenkasta, valjasta. Ovako duga $0·6\frac{1}{4}$. Tab. IV. br. 11.

V. Zemljano posudje.

A. Tanjuri.

1. Tanjur plosnast, bez podstavka i bez ukrasa do dva urezana okruga na vanjskoj strani. Sliepljen i nješto manjkav. Promjer 0·30, vis. 0·3. Tab. IV. br. 25.

2. Tanjur viencem prostranim i oblastim, i malenim podstavkom. Na viencu izbočito četiri slike kao ribe. Promjer 0·20, vis. 0·4.

3. Kao br. 2. Promjer $0·16\frac{1}{2}$, vis. $0·3\frac{1}{2}$.

4. Kao br. 2, nego bez ukrasa na viencu. Sliepljen i malko okrnut. Promjer $0·16\frac{1}{2}$, vis. $0·3\frac{1}{4}$.

5. Kao br. 4, nego naokolo na viencu žliebčić. Promjer $0·11\frac{1}{3}$, vis. $0·1\frac{1}{3}$. Tab. IV. br. 16.

6. Kao br. 4, ali bez podstavka. Malko odkrnjen. Promjer $0·5\frac{3}{4}$.

7. Tanjur crvenkast s podstavkom i dva uha do vienca, jedno prama drugomu, te na viencu naokolo žliebčić. Promjer $0·15\frac{1}{2}$, vis. 0·3.

8. Kao br. 7, no manji a višji. Promjer 0·11, vis. $0·4\frac{1}{2}$. Tab. IV. br. 17.

9. Tanjur glasiran, s podstavkom i dva uha do vienca, na kom dvie bočke po strani. Na dnu izvana utisnut znak tronožja. Promjer 0·22, vis. 0·3. Tab. III. br. 45.

10. Kao br. 9, ali bez znaka na dnu. Promjer $0·13\frac{1}{2}$, vis. $0·5\frac{1}{2}$.

11. Kao br. 10. Potresom razbit. Promjer $0·10\frac{1}{2}$, vis. 0·4. Tab. III. br. 38. Ova tri zadnja skupa našasta u grobu.

B. Zdjele.

1. Zdjela bez podstavka. Dno izvana ponješto oblasto, a iznutra dubčasto. Podvršje diže se nakoso. Promjer 0·17, vis. $0·3\frac{3}{4}$. Tab. IV. br. 27.

2. Kao br. 1, ali dno ravno. Okrnjena i sliepljena. Promjer 0·15, vis. $0·3\frac{3}{4}$.

3. Zdjela oblata, malim podstavkom. Izpod vienca izvana okrug na način užice izvaljan. Tab. IV. br. 26.

4. Kao br. 3, samo na okrugu crte poprečno položene. Promjer $0·15\frac{2}{3}$, vis. $0·5\frac{1}{3}$.

5. Kao br. 4. Okrnjena i sliepljena. Promjer 0·16, vis. 0·5.

6. Kao br. 2, nego na okrugu ukras dvostruk. Sliepljena. Promjer $0·15\frac{3}{4}$, vis. $0·4\frac{1}{2}$.

7. Kao br. 3, ali izpod vienca nema okruga. Promjer 0·15, vis. 0·4.

8. Kao br. 7. Sliepljena. Promjer 0·15, vis. 0·3.

9. Kao br. 7. Promjer $0·12\frac{1}{2}$, vis. $0·3\frac{1}{2}$.

10. Kao br. 3, nego se vienac uzvija izvana oblasto, te je izpod vienca sve naokolo poprečnimi crtami u više redova nakićena. Promjer $0·16\frac{1}{2}$, vis. $0·5\frac{1}{2}$.

11. Kao br. 3, no vienac plosnast, te i dublja. Sliepljena. Promjer 0·19, vis. $0·5\frac{1}{4}$.

12. Kao br. 11, ali izpod vienca prost okrug. Okrnjena. Promjer $0\cdot14\frac{1}{4}$, vis. $0\cdot4$.
13. Kao br. 3, nego grlo diže se osovno bez ukrasa, dno je prostranije i ravno, a podstavak širji. Promjer $0\cdot6$, vis. $0\cdot5$.
14. Na malenom podstavku širi se nakoso, a grlo se diže osovno. Na viencu jaružica naokolo. Promjer $0\cdot6$, vis. $0\cdot8$. Tab. IV. br. 28.
15. Na malom podstavku diže se oblasto. Izvana je ukrasena sa nizi od crtica razno izvedenimi i jednim od listića. Crnkasta i ponješto sliepljena. Promjer $0\cdot14$, vis. $0\cdot10$. Tab. III. br. 17.
16. Kao šalice, čunjastoga načina, bez podstavka, tanjahnja i smedje boje. Promjer $0\cdot10\frac{2}{3}$, vis. $0\cdot6\frac{1}{4}$. Tab. IV. br. 9.
17. Na malom podstavku diže se oblasto, no grlo se stiska postupno do vienca. Malko okrnjena, i crnkasta. Promjer $0\cdot10$, vis. $0\cdot6$. Tab. III. br. 22.
18. Kao br. 17. Promjer $0\cdot10$, vis. $0\cdot5\frac{1}{2}$.
19. Kao br. 17, ali izvana naokolo prostimi i crknjastimi okrugići bogato izkićena. Malko okrnjena. Promjer $0\cdot10$, vis. $0\cdot5\frac{1}{2}$.
20. Kao br. 17. Manjkava. Promjer $0\cdot9\frac{1}{4}$, vis. $0\cdot5$.
21. Kao br. 17, no doli izvana okrugići ukrasena. Promjer $0\cdot9\frac{1}{2}$, vis. $0\cdot5$.
22. Kao br. 17. Okrnjena. Promjer $0\cdot9\frac{3}{4}$, vis. $0\cdot5$.
23. Kao br. 17. Okrnjena. Promjer $0\cdot9\frac{1}{4}$, vis. $0\cdot5$.
24. Kao br. 17. Okrnjena. Promjer $0\cdot9$, vis. $0\cdot5$.
25. Kao br. 17. Sliepljena. Promjer $0\cdot8\frac{1}{2}$, vis. $0\cdot4\frac{1}{2}$.
26. Kao br. 7, nego izvana sa tri reda likova na način ljušturica urešena. Promjer $0\cdot8$, vis. $0\cdot4\frac{1}{2}$.
27. Kao br. 17, ali sa dvie ručice, jedna prama drugoj položena. Dolnji dio izvana nakićen okrugići prostimi i od crta. Okrnjena i sliepljena. Promjer $0\cdot8$, vis. $0\cdot5\frac{2}{3}$. Tab. III. br. 39.
28. Kao br. 27. Sliepljena i okrnjena. Promjer $0\cdot10\frac{1}{2}$, vis. $0\cdot6$.
29. Kao br. 27, ali izvana izpod vienca osobitim nakitom od zavojenih crta ukrasena. Sliepljena i okrnjena. Promjer $0\cdot13$, vis. $0\cdot8\frac{2}{3}$. Tab. IV. 30. (Konac sledi).

Arkeologičko izkapanje u Bakru.

(V. Viestnik 1881. br. 1, str. 1—9 sa 4 table, br. 2 str. 48—54.)

C. Vrčevi i čupovi.

1. Vrč sa ručicom i podstavkom. Grlić svršuje na način nosa, a tielo je okrugljasto. Na grliću izvana dvie jaružice. Manjkav. Promjer najveći $0\cdot16$, vis. $0\cdot18$.
2. Kao br. 1, no tielo manje okruglo. Manjkav. Promjer najveći $0\cdot15$, vis. $0\cdot18$.
3. Kao br. 1, ali trbuh prostraniji i plosnatiji. Grlić opao. Promjer najveći $0\cdot19$, vis. $0\cdot17$.
4. Kao br. 3, nego grlić čunjast, te jaružica, gdje se grlić s tielom spaja. Promjer najveći $0\cdot14$, vis. $0\cdot15$. Tab. III. br. 34.
5. Kao br. 3, bez podstavka, i sa okrugići oko trbuha. Dno dubčasto i krugljicom po sriedi. Promjer najveći $0\cdot10\frac{1}{2}$, vis. $0\cdot13\frac{1}{2}$.
6. Kao br. 1, no višji i tanji te primiereniji. Najveći promjer $0\cdot15$, vis. $0\cdot23$.
7. Kao br. 6. Malko okrnjen na nosu. Promjer najveći $0\cdot13$, vis. $0\cdot20$.
8. Kao br. 6, trbuh okrugljastiji. Promjer najveći $0\cdot13\frac{1}{2}$, vis. $0\cdot18\frac{1}{2}$.
9. Čup s grlićem valjastim, ručicom i podstavkom, a trbuhom na okrug. Probušen i sliepljen. Promjer na otvoru $0\cdot6$, najveći $0\cdot23$, vis. $0\cdot28$.
10. Kao br. 9, nego mu trbuh odulji. Sliepljen i probušen. Promjer na otvoru $0\cdot4\frac{1}{2}$, najveći $0\cdot20$, vis. $0\cdot24$.
11. Kao br. 10. Sliepljen i manjkav. Promjer najveći $0\cdot18$, vis. $0\cdot12$.
12. Kao br. 10. Okrnjen na viencu. Promjer najveći $0\cdot15\frac{1}{2}$, vis. $0\cdot20$.
13. Kao br. 10. Promjer na otvoru $0\cdot5$, najveći $0\cdot14\frac{1}{2}$, vis. $0\cdot20$.
14. Kao br. 10. Na viencu okrnjen. Promjer na otvoru $0\cdot5$, najveći $0\cdot14\frac{1}{2}$, vis. $0\cdot18\frac{1}{2}$.
15. Kao br. 10, nego na viencu dvostruki obruč, a izpod vienca naokolo jaružica. Promjer na otvoru $0\cdot4$, najveći $0\cdot14$, vis. $0\cdot17\frac{1}{2}$.
16. Kao br. 10. Debljina trbuha niže stoji, grlić opao. Promjer najveći $0\cdot11\frac{1}{2}$, vis. do grlića $0\cdot15\frac{1}{2}$.

17. Kao br. 10. Na trbuhu više prutaka. Promjer na otvoru $0\cdot5\frac{1}{2}$, najveći $0\cdot13\frac{1}{2}$, vis. $0\cdot21$.
18. Kao br. 10. Trbuh prostraniji i plosnatiji. Promjer na otvoru $0\cdot5\frac{1}{2}$, najveći $0\cdot20$, vis. $0\cdot20$. Tab. III. br. 36.
19. Kao br. 18. Trbuh ponješto uglast. Okrnut na grliću. Promjer na otvoru $0\cdot5\frac{1}{2}$, najveći $0\cdot20$, vis. $0\cdot22$.
20. Kao br. 18. Bez grlića i probušen. Promjer najveći $0\cdot18$, vis. do grlića $0\cdot13$.
21. Kao br. 18. Promjer na otvoru $0\cdot5$, najveći $0\cdot15$, vis. $0\cdot17$.
22. Kao br. 18. Trbuh okrugliji a dno obsežnije. Okrnut na grliću. Promjer na otvoru $0\cdot4\frac{1}{2}$, najveći $0\cdot14$, vis. $0\cdot15$.
23. Kao br. 18. Promjer na otvoru $0\cdot4\frac{1}{2}$, najveći $0\cdot12$, vis. $0\cdot15$.
24. Kao br. 18. Na trbuhu više prutaka. Manjka grlić i komad tiela. Promjer najveći $0\cdot10$, vis. do grlića $0\cdot9$.
25. Kao br. 9, ali trbuh po sriedi teče ravno, te ova i gornja strana čupa crticami ukrasena. Grlić je prostraniji, a na viencu dvostruki prutak. Okrnjen na rubu. Promjer na otvoru $0\cdot7\frac{3}{4}$, najveći $0\cdot18$, vis. $0\cdot18\frac{1}{2}$.
26. Kao br. 9, no grlić veoma prostran i visok mal. ne koliko i trbuh. Ručica i komad grlića manjka. Promjer na otvoru $0\cdot10$, najveći $0\cdot15$, vis. $0\cdot16$. Tab. III. br. 23.
27. Kao br. 9, no bez grla, poduljastog trbuha, a prucei naokolo ukrasen. Promjer na otvoru $0\cdot7$, najveći $0\cdot11$, vis. $0\cdot15\frac{1}{2}$.
28. Kao br. 27, nego na viencu izbočita vezica, a podstavak višji. Promjer na otvoru $0\cdot7$, najveći $0\cdot8$, vis. $0\cdot11$. Tab. IV. br. 29.
29. Kao br. 28. Sliepljen. Promjer na otvoru $0\cdot6\frac{1}{2}$, najveći $0\cdot8$ vis. $0\cdot12$.
30. Kao br. 27, nego bez podstavka, a najveća debljina trbuha stoji niže. Na viencu vezica ravna. Promjer na otvoru $0\cdot6\frac{1}{2}$, najveći $0\cdot10$, vis. $0\cdot15$.

31. Kao br. 30. Sliepljen. Promjer na otvoru $0\cdot6\frac{1}{2}$, najveći $0\cdot10\frac{1}{2}$, vis. $0\cdot15$.

D. Lonci.

a) Lonci bez ručice.

1. Lonac crnkast, prostom rukom sastavljen, i slabo izpečen te nalici na predhistoričke. Nema podstavka, a dno mu ravno. Promjer na otvoru $0\cdot8\frac{1}{2}$ — $0\cdot9$, na dnu $0\cdot6\frac{1}{2}$, vis. $0\cdot10$ — $0\cdot11$. Tab. III. br. 24.
2. Kao br. 1, žutkaste boje. Promjer na otvoru $0\cdot10$, na dnu $0\cdot9$, vis. $0\cdot11\frac{1}{2}$.
3. Kao br. 2. Na dnu oblučne crte. Pravilnije izradjen. Promjer na otvoru $0\cdot9$, na dnu $0\cdot5$, vis. $0\cdot11\frac{1}{2}$.
4. Kao br. 3, ali bolje radnje. Na viencu dva okruga. Promjer na otvoru $0\cdot8\frac{1}{4}$, na dnu $0\cdot5$, vis. $0\cdot9\frac{1}{2}$.
5. Kao br. 4. Promjer na otvoru $0\cdot6\frac{1}{3}$, na dnu $0\cdot3\frac{3}{4}$, vis. $0\cdot7\frac{1}{2}$.
6. Kao br. 4. Promjer na otvoru $0\cdot8\frac{1}{4}$, na dnu $0\cdot9\frac{1}{2}$, vis. $0\cdot9\frac{3}{4}$.
7. Lonac na uglove, jaružicom naokolo po sriedi. Promjer na otvoru $0\cdot5$, vis. $0\cdot8\frac{1}{4}$. Tab. III. br. 27.
8. Lonac okruglastnim dnom i prucei sve naokolo izkićen. Promjer na otvoru $0\cdot8$, vis. $0\cdot8\frac{3}{4}$.
9. Kao br. 8, nego niži a širji i s malim podstavkom. Promjer na otvoru $0\cdot10\frac{2}{3}$, na dnu $0\cdot4\frac{1}{4}$, vis. $0\cdot7\frac{1}{2}$.
10. Lonac čunjasta oblika, malim podstavkom, izvana ukrasen piknjastimi okruglji. Vienac se k nutri giblje. Promjer na otvoru $0\cdot6\frac{2}{3}$, na dnu $0\cdot2\frac{1}{2}$, vis. $0\cdot7\frac{2}{3}$. Tab. IV. br. 23.

b) Lonci sa jednom ručicom.

1. Lonac trbušat, bez postavka, izbočitim viencem i okruglastim dnom, izvana naokolo prucei uresen. Promjer na otvoru $0\cdot9$, vis. $0\cdot9\frac{1}{2}$.
2. Kao br. 1. Promjer $0\cdot9\frac{1}{2}$, vis. $0\cdot9$.
3. Kao br. 1. Promjer $0\cdot8\frac{1}{2}$, vis. $0\cdot9\frac{1}{2}$.
4. Kao br. 1. Sliepljen i probušen. Promjer $0\cdot7\frac{1}{2}$, vis. $0\cdot8$.
5. Kao br. 1. Okrnjen i sliepljen. Promjer $0\cdot7$, vis. $0\cdot7\frac{1}{2}$.
6. Kao br. 1. Promjer $0\cdot7\frac{1}{2}$, vis. $0\cdot9\frac{1}{2}$.
7. Kao br. 1. Sliepljen i jako okrnjen. Promjer $0\cdot8$, vis. $0\cdot10$.
8. Kao br. 1. Sliepljen, okrnjen i bez ručice. Promjer $0\cdot7$, vis. $0\cdot8\frac{1}{2}$.
9. Kao br. 1. Promjer $0\cdot8$, vis. $0\cdot10$.

10. Kao br. 1. Na viencu okrnjen. Promjer 0·8, vis. 0·10.
11. Kao br. 1. Malko okrnjen. Promjer $0·7\frac{1}{2}$, vis. 0·10.
12. Kao br. 1. Okrnjen i sliepljen. Promjer 0·7, vis. 0·9.
13. Kao br. 1. Na rubu jedva okrnjen. Promjer $0·6\frac{1}{2}$, vis. 0·9.
14. Kao br. 1. Doli naokolo prutei. Promjer 0·7, vis. 0·9.
15. Kao br. 1. Okrnjen na viencu. Promjer 0·7, vis. 0·7.
16. Kao br. 1. Bez ručice i okrnjen. Promjer $0·6\frac{2}{3}$, vis. $0·7\frac{1}{2}$.

c) Lonci sa dvie ručice.

1. Lonac veoma pravilnoga oblika i malim podstavkom. Promjer na otvoru 0·10, vis. 0·16.
2. Kao br. 1. Bez jedne ručice i na viencu okrnjen. Promjer 0·11, vis. $0·14\frac{1}{2}$.
3. Kao br. 1. Bez jedne ručice, i na viencu okrnjen. Promjer 0·8, vis. $0·10\frac{1}{2}$.
4. Kao br. 1. Promjer $0·6\frac{3}{4}$, vis. $0·10\frac{1}{2}$.

E. Viedra i žare.

1. Viedro sa dvie ručke, bez podstavka. Izvana izpod čunjastoga grla naokolo prutak. Promjer na otvoru 0·7, najveći 0·27, vis. 0·43. Tab. III. br. 37.
2. Kao br. 1, ali bez prutka. Na viencu okrnjeno. Promjer na otvoru $0·6\frac{1}{2}$, najveći 0·27, vis. 0·43.
3. Kao br. 1. Promjer na otvoru 0·6, najveći 0·25, vis. $0·40\frac{1}{2}$.
4. Kao br. 2. Obe ručke opale. Promjer na otvoru 0·6 najveći, 0·24, vis. 0·42.
5. Kao br. 2. Promjer na otvoru $0·5\frac{1}{2}$, najveći 0·15, vis. 0·27.
6. Kao br. 2, ali na truhu naokolo niz čunjastih piknja. Sliepljeno i probušeno. Promjer na otvoru 0·6, najveći 0·10, vis. 0·14. Tab. IV. br. 24.
7. Kao br. 2. Na viencu okrnjeno. Promjer na otvoru 0·7, najveći 0·11, vis. $0·15\frac{1}{2}$.
8. Kao br. 2. Sliepljeno i manjkavo. Promjer najveći 0·9, vis. 0·13.
9. Viedro sa jednom ručkom, malim podstavkom, bez grla, obširnim otvorom, i veoma trbučasto. Promjer na otvoru 0·16, najveći 0·38, na dnu 0·16, vis. 0·45. Tab. III. br. 25.
10. Žara sa malim podstavkom i jaružicom na truhu. Grlo i ručke manjkaju. Promjer najveći 0·22, na dnu $0·11\frac{1}{2}$, vis. ovako 0·47. Tab. IV. br. 36.
11. Žara na dolnjoj strani šiljasta, sa dvie ručke, koje su većinom opale. Promjer najveći 0·29, vis. 0·80. Tab. IV. br. 31.
12. Kao br. 11, nego sva teče šiljasto na pravi čunj. Manjka grlo i veći dio ručica. Promjer najveći 0·24, ovako vis. 0·64. Tab. IV. br. 34.
13. Kao br. 12, ali bez ručke, a s većim otvorom. Promjer na otvoru $0·18\frac{1}{2}$, najveći 0·24, vis. 0·64. Tab. III. br. 19.
14. Kao br. 13, no u tielu obsežnija. Promjer na otvoru 0·26, najveći 0·33, vis. 0·44.
15. Kao br. 14. Na viencu sve naokolo manjkava. Promjer najveći 0·28, vis. 0·38.

F. Poklopci.

1. Poklopac velike posude, ravan, crvenkast. Sliepljen i okrnjen. Promjer 0·15.
2. Poklopac načina čunjasta. Promjer 0·11. Tab. III. br. 32.
3. Kao br. 2. Sliepljen i probušen. Promjer 0·12.

4. Kao br. 2. Žliebčiči na viencu, izpod vienca i na dnu izvana. Promjer $0·10\frac{1}{2}$. Tab. III. br. 31.
5. Kao br. 2. Promjer $0·7\frac{1}{2}$.
6. Kao br. 2. Promjer $0·7\frac{3}{4}$.
7. Kao br. 2. Promjer 0·7.
8. Kao br. 2. Promjer $0·7\frac{1}{4}$.
9. Kao br. 2. Okrnjen i sliepljen. Promjer 0·7.
10. Poklopac prost, čunjast, kugljicom odozgo. Promjer 0·12.

G. Posude zemljene osobitog oblika.

1. Lopiža na način mjedene kotluše. Dno joj oblasto, vjenac razito se vani pruža, ne ima ručica, a surova posla. Promjer na otvoru 0·24, a vis. 0·17. Tab. IV. br. 21.
2. Plaska pakrugastog načina, dugim grličem sa dva okruglića neupravno urezana, bez postavka tako da jedva stajati može, prilična grčkomu *alabastron* (Jahn Tab. II. br. 76). Najveći promjer 0·6, na otvoru 0·3¹/₄ a duga 0·16¹/₂. Tab. III. br. 12.
3. Posuda bez ručica, jaružicom po sriedi, koja ju na dvie pole razstavlja. Na grliču kao široka užica. Najveći promjer 0·10, na otvoru 0·3¹/₂, a vis. 0·12¹/₂. Potrena i manjkava. Tab. IV. br. 12.
4. Zdjela na način umivaonika za ociedjenje tekućina, sa noscem, na kom tri jaružice strmo nagnute. Promjer 0·15, vis. 0·5. Tab. IV. br. 20.
5. Posuda sa podstavkom u spodobi kokota. Grlo stoji nakoso na hrbtu. Vis. 0·23¹/₄, dug. 0·27. Tab. IV. br. 18.

VI. Svietiljke.¹⁾

A. Svietiljke slikane.

1. Glava Palade kacigasta lievo, drži koplje i štit.

Samo veći dio gornje ploče, pošto se ostalo nje našlo zdrobljeno. V. Tab. III. br. 4. Medju komadi bijaše sljedeći novac:

TI CLAVDIVS CAESAR AVG P M TR P IMP. — Glava Klaudijeva gola lievo okrenuta.

S.C. — Pallas, stojeć desno, baca strielicu i drži štit (god. 41. po Is.).

Srednji bronz. Cohen I. 165 br. 87.

2. Amor pred stupom nabožke okrenut. Do noguh mu kao dvie posude, po jedna sa svake strane i tulica.

Nosac manjka. Promjer 0·8¹/₄. Tab. III. br. 14.

ANTONIA AVGVSTA. — Poprsje Antonije desno; vlasi u čepecu.

TI CLAVDIVS CAESAR AVG P M TR P IMP. — **S.C.** —

Cesar Klaudij, stojeć lievo, drži u desnici žrtveničku posudu (kovan za Klaudija g. 41–54. po Is.).

Srednji bronz. Cohen I. 136 br. 6. Antonia, kćer triumvira M. Antonia i Oktavije Augustove, bijaše udata za Nerona Drusa, od kojega dob više sinova, medju kojima su bili Germanik i cesar Klaudij. Kaligula, njezin unuk, dao ju otrovati g. 39. po Is.

3. Amor desno okrenut.

Ciela. Promjer 0·8, duljina 0·10²/₃. Crveno-žutkasto glasirana.

IMP CAES VESPASIAN AVG COS III. — Glava Vespasianova lovorvjenčana desno.

VICTORIA NAVALIS. — **S.C.** — Pobjeda, stojeća na provi ladje, koja se sa zmijom dokončava, drži vienac i paomu (god. 71 po Is.).

Srednji bronz. Cohen I. 331 br. 502.

4. Muškarac žuri lievo, te odjeća mu u letu.

Ciela. Promjer 0·7, dulj. 0·10. Tab. III. br. 13. Bjaše crveno bojadisana. — Novac kao pod br. 1.

5. Amor brzim korakom ide lievo, držeć sulicu u desnici. Na dnu izvana T izbočito.

Ciela. Promj. 0·7¹/₂, dulj. 0·10¹/₂. — Novac veoma iztrošen. Jedva se razaznaje u predku **AVG GERM.**

*) Doba rimskih svietiljka starinari ograničuju u obće na prva tri stoljeća po Is. (*V. Passerius: Lucernae fictiles Musei Passerii. Pisauri 1743. I. prol. p. XVI*). Millin (*Monuments antiques inédits etc. Paris 1806. II. 165*) dieli jih na tri vrsti, naime proste, napisane i slikane, te da su prve i najstarije, druge iz augustova doba, a treće iz adrijanova. Netemeljitost Millinove tvrdnje dokazuju jasno ove naše svietiljke. Mi smo uz kratki njihov opis označili po Cohenu u koliko se dalo i novac, koj se je na dotičnoj svietiljci našao; a mal ne sve su imale svoj bakreni novac u gornjoj praznini položen. To smo učinili i zato, da tvrdnju Millinovu sve bolje suzbijemo. Pravost pako naših svietiljka stoji van svake sumnje. O njih veoma je viešo razložio dobro poznati F. Kenner u svom djelu: *Die antiken Thontampen etc. Wien 1858.*

6. Amor u hodu desno. Na dnu izvana urezano I.

Ciela. Promj. 0.7, dulj. 0.10.

DIVVS AVGVSTVS. — S.C. — Glava zračna Oktavianova lievo.

DIVA AVGVSTA. — Livija stojeć lievo, drži klas, mak i zubljui

Srednji bronz kovan za Tiberija (g. 14—37 po Is.). Cohen I. 70. br. 264. Uz ovu svietiljku nadjen je zlatni prsten (Viest. 1882 str. 7, br. 2) i posuda od bronza (l. c. br. 1).

7. Siedeća osoba lievo, slabo sačuvana.

Ciela. Promj. $0.8\frac{1}{4}$, dulj. 0.12.

DIVA FAVSTINA. — Poprsje Faustine starije desno.

S.C. — Hram od šest stupova, liepo izkićen.

Veliki bronz slabo sačuvan. Cohen II. 451 br. 173—174. Vriednost 100 frs.

8. Krupan pas trči lievo.

Ciela. Promj. $0.7\frac{1}{2}$, dulj. $0.10\frac{3}{4}$. Novac zametnut.

9. Jaruh u trku desno. Na dnu izvana T izbočito.

Ciela. Promj. $0.7\frac{1}{2}$, dulj. $0.10\frac{1}{2}$. Tab. III. br. 15. Novac zametnut.

10. Jaruh ležeć desno.

Ponješto manjkava. Promj. $0.7\frac{1}{2}$, dulj. $0.10\frac{1}{2}$.

NERO CLAVD. CAESAR AVG. GER P M TR P IMP P P. — Glava zračna Neronova desno.

ROMA — S.C. — Rim kacigast sjedi lievo na snopu oružja; noga mu na kacigi; drži vienac i pas, a koplje se izada nevidi (g. 54—68 po Is.).

Cohen I. 204 br. 240.

11. Prase hrli desno.

Samo gornji komad, pošto se svietiljka razdrobila. Novac zametnut. Tab. III. br. 11.

12. Prase koraca desno. Na dnu izvana okrugić izbočito.

Ciela. Promj. $0.7\frac{1}{2}$, dulj. $0.10\frac{1}{4}$. — Novac kao pod br. 1.

13. Prase u trku desno.

Ciela. Promj. 0.8, dulj. $0.11\frac{1}{2}$.

Novac veoma iztrošen, te se u predku razaznaje glava cesareva desno, a od nadpisa: *Imp. Caes Ner VA TRAI—AN AVG GE*.... (god. 98—117 po Is.).

14. Zec jede voće viseće o grančici. Na dnu izvana okrugić sa piknjom po sried i četiri brnice vani na krst.

Ciela. Promj. $0.7\frac{1}{2}$, dulj. $0.10\frac{1}{2}$. Tab. IV. br. 39.

Diva **FAVSTINA.** — Poprsje Faustinovo desno.

AETERNITAS. — S.C. — Viečnost, stojeć lievo, drži u desnici kruglju, nad kojom se diže phoenix, a lievicom podiže skutove svoje odjeće.

Srednji bronz. Cohen II. 439 br. 142.

15. Kokot desno.

Ciela. Promj. $0.7\frac{1}{2}$, dulj. 0.10.

HADRIANVS AVGVSTVS. — Glava cesareva lovorvjenčana desno.

S.C. — Zdravost, stojeć desno, pita zmiju, koja joj na mišici stoji.

Srednji bronz. Cohen II. 244 br. 1118. Vr. 10 fr.

16. Pliskavica desno. Nješto kao orudje izpod nje.

Ciela. Promj. $0.7\frac{1}{2}$, dulj. $0.10\frac{1}{2}$. Tab. III. br. 16. Novac zametnut.

17. Pliskavica lievo.

Ciela. Promj. 0.6, dulj. $0.8\frac{1}{2}$. Novac posvema izjeden.

18. Pliskavica kao br. 17.

Ciela, te iste veličine kao br. 17, ali lošije radnje, a novac sasvim pokvaren.

19. Hižica preko koje na sukrst Merkurov štap i kita.

Malko okrnjena. Promj. $0.6\frac{1}{4}$, dulj. $0.8\frac{1}{2}$.

HADRIANVS — AVGVSTVS. — Glava cesareva lovorvjenčana desno.

.....VS — AVGVSTI. — S.C. — Osoba lievo okrenuta stojeća, drži desnicu povrh žrtvenika a u lievici žezlo ili koplje.

Srednji bronz slabo sačuvan. Sr. Cohen II. 242 br. 1108.

20. Žrtvenik gorući, pošto se uzvijaju oblaci od dima.

Ciela. Promj. $0.6\frac{1}{2}$, dulj. $0.8\frac{3}{4}$.

DIVA FAVSTINA. — Poprsje Faustinovo desno.

AVGVSTA. — S.C. — Vesta, stojeća lievo, drži u desnici pliticu nad žrtvenikom, a u lievici *paladium*.

Srednji bronz slabo sačuvan. Cohen II. 444 br. 199.

21. Zvezda.

Ciela. Promj. $0.7\frac{1}{2}$, dulj. $0.8\frac{1}{2}$.

ANTONINVS AVG PI—VS P P TR P COS III. — Antoninova glava lovorvjenčana desno.

LIBERALITAS IIII. U podkrajku **S.C.** — Antonin sjedi lievo na plokati. Pred njim boginja darovitosti, držeći rovaš i obilnicu. Doli izpred plokate stoji čovjek s rukama pruženima napram caru kao da ga moli (god. 145 po Is.).

Cohen II. 370 br. 661. V. 10 fr.

22. Čini se, da je bila njeka posuda.

Jako izgledana. Promj. $0,7\frac{3}{4}$, dulj. 0.11. Novac iztrošen.

B. Svietiljke napisane.

1. Na dnu izvana ATIME.

Ciela. Promj. 0.7, dulj. $0.10\frac{1}{2}$. Novac nečitljiv.

2. Kao br. 1., ali raznoga posla.

Ciela. Promj. 0.8, dulj. $0.11\frac{1}{2}$.

IMP CAES NERVA TRAIAN AVG GERM P M. — Glava Trajanova lovorvjenčana desno.

TR POT COS III P P. — S.C. — Pobjeda korači lievo, držeć paomu u desnici a u lievici štít, na kom se čita **S P Q R** (god. 100 po Is.).

Srednji bronz. Cohen II. 82 br. 525.

3. Na dnu izvana ATIMETI u dvostrukom okrugu.

Bez nošca i gornje strane. Promj. 0.7. Novac zametnut.

4. Na dnu izvana u dvostrukom okrugu CANNEI.

Ciela. Promj. $0.7\frac{1}{4}$, dulj. $0.10\frac{1}{2}$.

FAVSTINAE AVG PII AVG FIL. — Poprsje Faustine desno.

VENERI GENETRICI. — S.C. — Venus, stojeć lievo, drži jabuku i djete povito.

Srednji bronz slabo sačuvan. Cohen II. 602 br. 224.

5. Na dnu izvana CASSI.

Ciela. Promj. 0.7, dulj. 0.10.

DIVVS AVGVSTVS PATER. — Glava Augustova zračna lievo.

IMP T VESP AVG REST. — S.C. — Razkriljen orao nad krugljom lievo.

Srednji bronz. Cohen I. 99 br. 486. V. 10 fr.

6. Na dnu izvana COMAVNIS.

Ciela. Promj. $0.7\frac{3}{4}$, dulj. $0.11\frac{1}{4}$. Novac zametnut.

7. Na dnu izvana *cr*ESCES.

Na dnu manjkava. Promj. $0.7\frac{2}{3}$, dulj. 0.11.

L AEL AVREL COMM AVG P FEL. — Glava Komodova lovorvjenčana desno.

P M TR P XVII IMP VIII COS VII P P. — S.C. — Osoba lievo okrenuta, drži nješto u desnici spreda, a u lievici zada čini se obilnicu. Pred njom doli kao vjenac ili žrtvenik.

Srednji bronz slabo sačuvan. Sr. Cohen III. 161 br. 683—697.

8. Na dnu izvana *Cresces*.

Manjkava. Promj. $0.7\frac{1}{2}$, dulj. $0.10\frac{1}{2}$. Novac iztrošen, a po glavi čini se, da je Nerve.

9. Na dnu izvanaS u dvostrukom okrugu.

Samo otražnji komad. Promj. $0.8\frac{1}{4}$. Novac zametnut.

10. Na dnu izvana C DESSĪ.

Ciela. Promj. $0.6\frac{1}{2}$, dulj. $0.9\frac{1}{2}$. — Na novcu u predku jedva se vidi cesareva glava lievo okrenuta, a od nadpisa: ...**DOMITIAN COS II**; u zadku pako stojeća osoba.

11. Na dnu izvana FAOR.

Ciela. Promj. 0.6, dulj. 0.9.

IMP T CAES VESP AVG P M TR P COS VIII. — Titova glava lovorvjenčana desno.

GENIO — P R. — S.C. — Genij, stojeći lievo, drži u desnici žrtvenicu a u lievici obilnicu. Pred nogama gorući žrtvenik (god. 80 po Is.).

Srednji bronz. Cohen I. 362 br. 182. V. 6 fr.

12. Na dnu izvana FELIX.

Ciela. Promj. 0.7, dulj. $10\frac{1}{2}$.

ANTONINVS AVG PIVS P P. — Glava Antoninova lovorvjenčana desno.

TR P COS III. — S.C. — Sreća, stojeća lievo, drži u desnici spreda kormilo, a u lievici zada obilnicu.

Srednji bronz slabo sačuvan. Cohen II. 398 br. 883.

13. Na dnu izvana u dvostrukom okrugu FORTIS.

Manjka komad tiela i nosca. Novac zametnut.

14. Isto kao br. 13.

Ciela. Promjer $0.7\frac{1}{2}$, dulj. 0.11. Novac zametnut.

15. Isto kao br. 14.

16. Isto kao br. 14.

17. Isto kao br. 14.

18. Isto kao br. 14.

19. Isto kao br. 14.

ANTONINVS AVG PIVS P P TR P COS III. — Glava Antoninova lovorvjenčana desno.

SECVRITAS AVG. — S.C. — Boginja sigurnosti, stojeća desno, drži u desnici žezlo, a u lievici skut svoga odjela.

Sr. Cohen II. 391 br. 828. Blizu ovoga našao se je još drugi novac Faustine kako gori A. br. 10, nego Vesta u zadku drži u desnici goruću baklju. Cohen II. 443 br. 197.

20. Isto kao br. 14.

Samo donji komad.

21. Na dnu izvana IANVAR

I

Ciela. Promj. $0.7\frac{1}{2}$, dulj. 0.10. Novac zametnut.

22. Gori po sriedi glava satira, a doli na dnu izvana u dvostrukom okrugu LITOGENE. Prva tri slova su spojena.

Ciela. Promj. $0.6\frac{3}{4}$, dulj. $0.10\frac{1}{2}$. Novac zametnut.

23. Na dnu izvana LITOGENE. Zada ručica opala.

Ciela. Promj. 0.7, dulj. $0.10\frac{1}{2}$. Novac zametnut.

24. Na dnu izvana u trostrukom okrugu LVCIVS.

F

Manjkava sa strane. Promj. $0.7\frac{1}{2}$, dulj. $0.10\frac{3}{4}$. Novac zametnut.

25. Na dnu izvana u dvostrukom okrugu LVPATI.

Ciela. Promj. 0.6, dulj. 0.9. Novac veoma iztrošen.

26. Na dnu izvana OCTAVI.

Novac razbit. Promj. 0.7, dulj. 0.10.

IMP CAESAR TRAIAN HADRIANVS AVG. — Poprsje Adrianovo lovorvjenčano desno.

P M TR P COS III. — S.C. — Mir, stojeći lievo, drži u desnici kitu lovorike a u lievici obilnicu.

Srednji bronz. Cohen II. 230 br. 1015.

27. Na dnu izvana okruglic sa piknjom, a pod njim PVLLI.

Ciela. Promj. 0.7, dulj. $0.10\frac{1}{2}$. Novac iztrošen.

28. Na dnu izvana SEXTI.

Ciela. Promj. $0.5\frac{1}{2}$, dulj. 0.8. Novac nečitljiv.

29. Na dnu izvana STROBILI u dvostrukom okrugu.

Gori po sriedi manjkava. Promj. 0.8, dulj. $0.11\frac{1}{2}$. Novac zametnut.

30. Isto kao br. 29.

31. Na dnu izvana VERI.

Ciela. Promj. 0.7, dulj. 0.10.

HADRIANVS AVG COS III P P. — Glava Adrianova lovorvjenčana desno.

S.C. — Diana, stojeć lievo drži u desnici spreda luk a u lievici štap.

Novac slabo sačuvan. Sr. Cohen II. 243 br. 1112.

32. Na dnu izvana VIBIANI.

Ciela. Promj. $0.7\frac{1}{2}$, dulj. $0.10\frac{1}{2}$. Novac zametnut.

33. Isto kao br. 32, samo promj. 0.6, dulj. 0.9.

34. Jedan ulomak nadpisa ...IAN. valjda *Vibiani*.

35. Na dnu izvana Ic. Zada ručka sa luknjom.

Ciela. Promjer 0.7, dulj. 0.11.

36. Na dnu izvana bio je nadpis, ali je sada nečitljiv.

ANTONINVS AVG PIVS PP TR P COS IIII. — Glava Antoninova lovorvjenčana desno.

S.C. — Pallas kacigasta, stojeć desno, baca strielicu i drži štit (god. 145 po Is.).

Cohen II. 387 br. 798.

C. Svietiljke proste, naime bez slike i nadpisa.

1. Malko ozledjena. Promj. $0.6\frac{1}{4}$, dulj. $0.8\frac{3}{4}$.
2. Čunjastom rupom po sriedi. Promj. 0.7, dulj. 0.9.
3. Na način plavčice sa probušenom ručkom gori, a polukrugljicami sva ukrasena.

Ciela. Duga $0.11\frac{1}{2}$, vis. 0.8. Tab. IV. 48.

VII. Cigle.

Iz bakarskoga rimskoga groblja povadilo se je tečajem izkapanja veliki broj ogromnih cigala (V. Tab. I. f). Od njih su grobovi većinom sastavljeni bili. Na mjestu prikazivale su se kao ciele, ali malo jih se našlo u zdravom stanju, pošto vlažnost i težina nadstojeće zemlje bijahu uzrokom, da se pokvare, te da se u izkapanju razstave i razdrobe. Njekoliko bolje sačuvanih, koje su pečat tvornice, iz koje su polazile, na sebi nosile, donešene su u zemalj. muzej. Ti pečati jesu:

1. NERONS CLA PN. — Dug 0.15, šir. 0.3. Takova četiri komada.
2. TI PANSINA. — Dug $0.15\frac{1}{2}$, šir. $0.2\frac{1}{2}$. Takova dva komada.
3. PANSIANA. — Dug 0.16, šir. $0.4\frac{1}{4}$ ili dug. $0.15\frac{1}{2}$, šir. 0.4. Takova tri komada.
4. SOLONAS. — Dug 0.16, 0.17 i 0.19, a šir. $0.3\frac{1}{2}$ i $0.4\frac{1}{2}$. Takova 3 komada.

VIII. Predmeti od kamena.

1. Ploče brusaonice na način pačetvorine, kao dolnji suvodni usjeci piramide. Boje su biljaste, ili modraste ili smeđe. Tab. III. br. 29.

- a) Duga $0.13\frac{1}{4}$, šir. 0.7.
- b) Duga $0.12\frac{3}{4}$, šir. $0.7\frac{1}{2}$.
- c) Duga 0.11, šir. 0.8
- d) Duga $0.10\frac{1}{4}$, šir. $0.6\frac{3}{4}$.
- e) Duga $0.7\frac{3}{4}$, šir. $0.4\frac{1}{2}$.

2. Žare. Ima jih do 21. Dvadeset su valjastoga načina. Ovim je poklopac obao, osim na jednom, gdje malne ravan, a višina i promjer u njih razni su, naime najmanja je vis. 0.36 sa promjerom 0.26, a najveća je vis. 0.55 sa promjerom 0.45. Jedna je samo četverouglasta, vis. 0.38, po stranah tiela duga 0.38, a po stranah poklopa 0.42. Tab. I. h i Tab. III. br. 20.

Rimsko
GROBIŠTE I GROBI

izkopani u Bakru

prof. S. Ljubić-em.

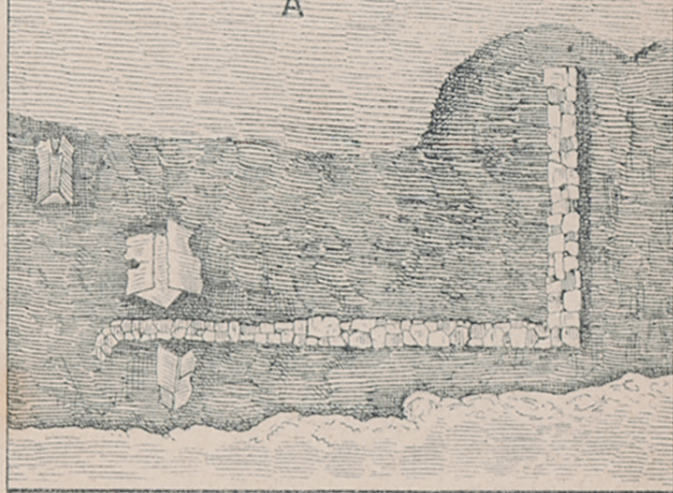
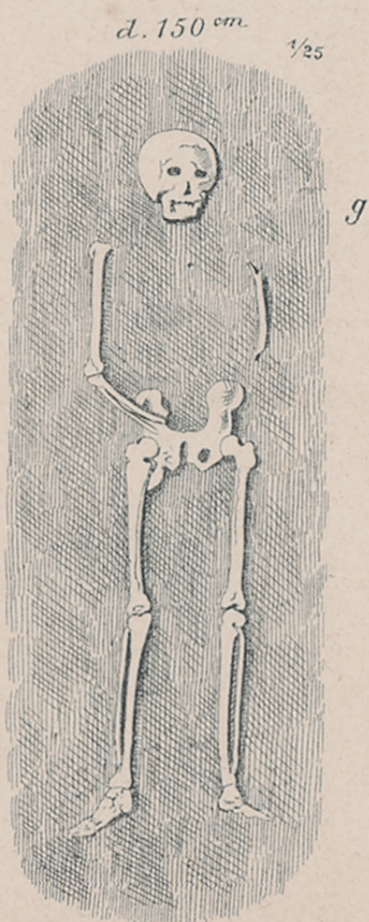
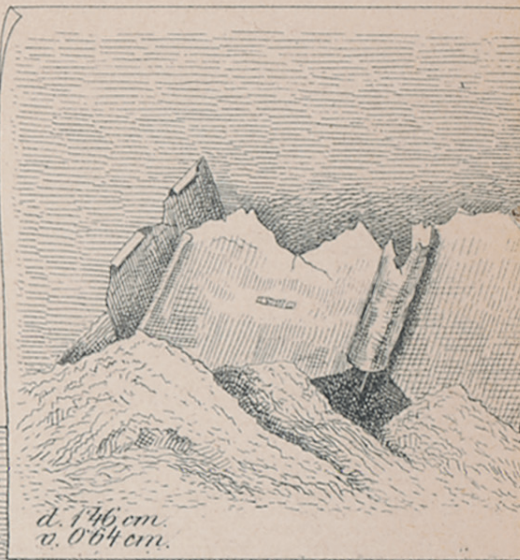

Odheric

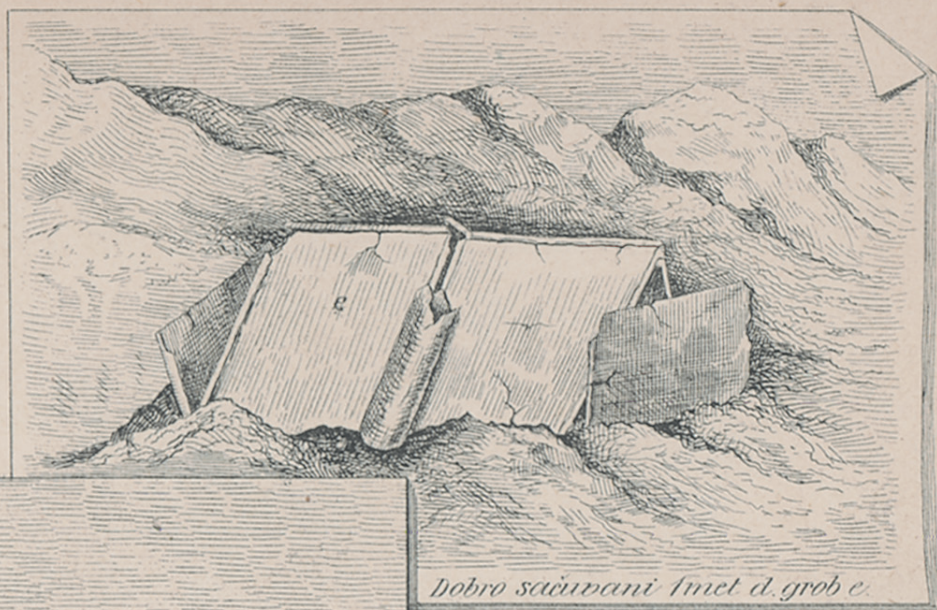
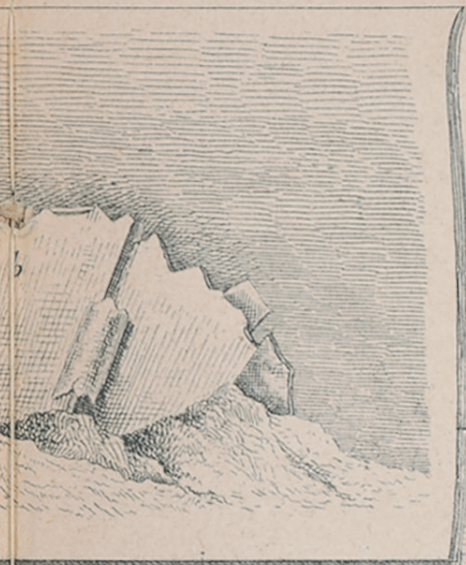

Dobro sačuvani smet d. grob e.

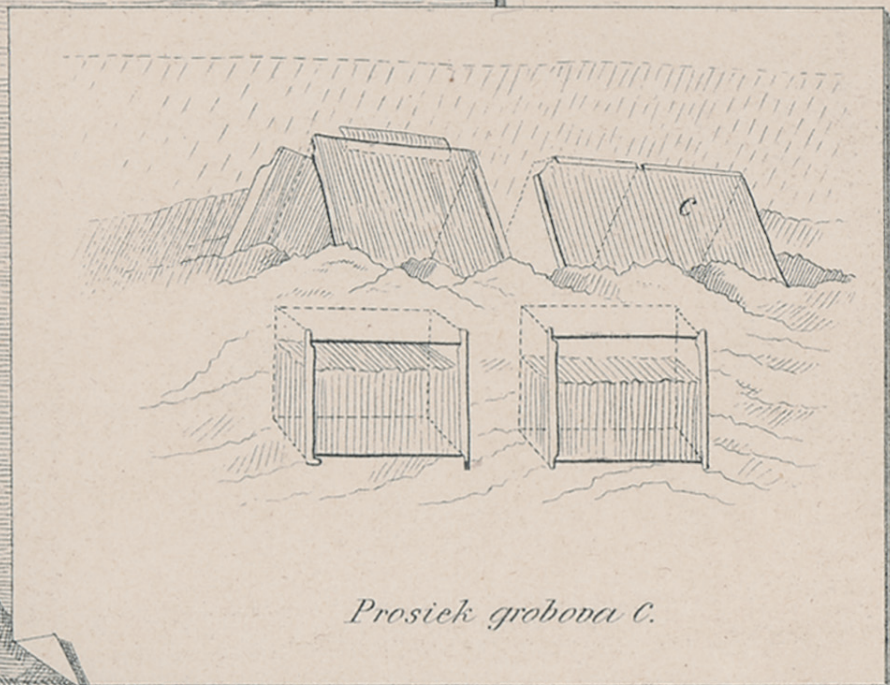
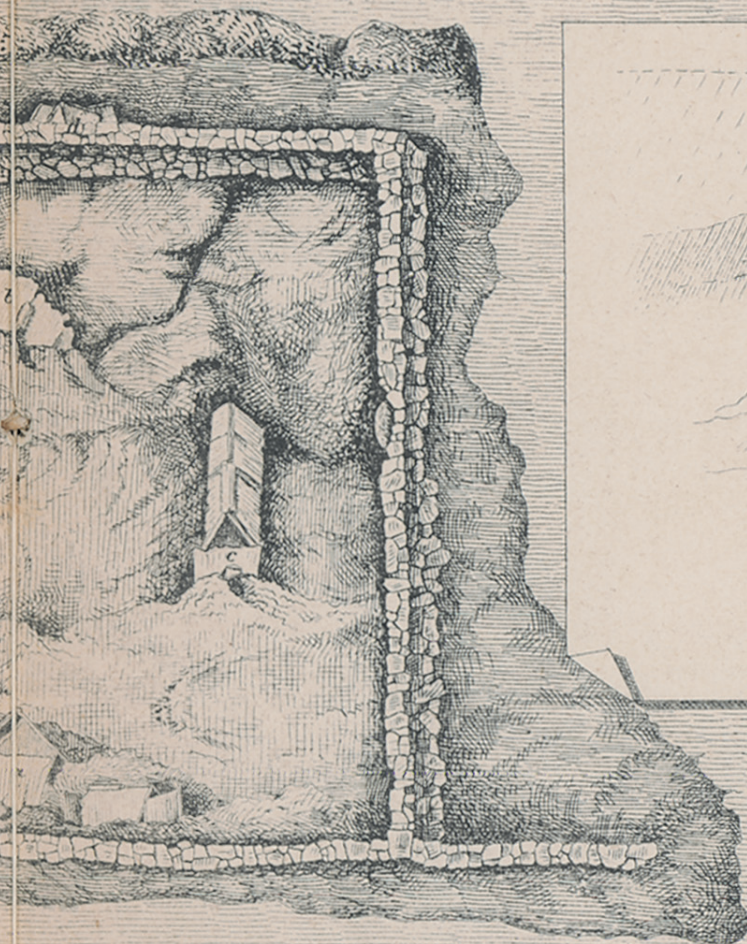

Prosiek grobova C.

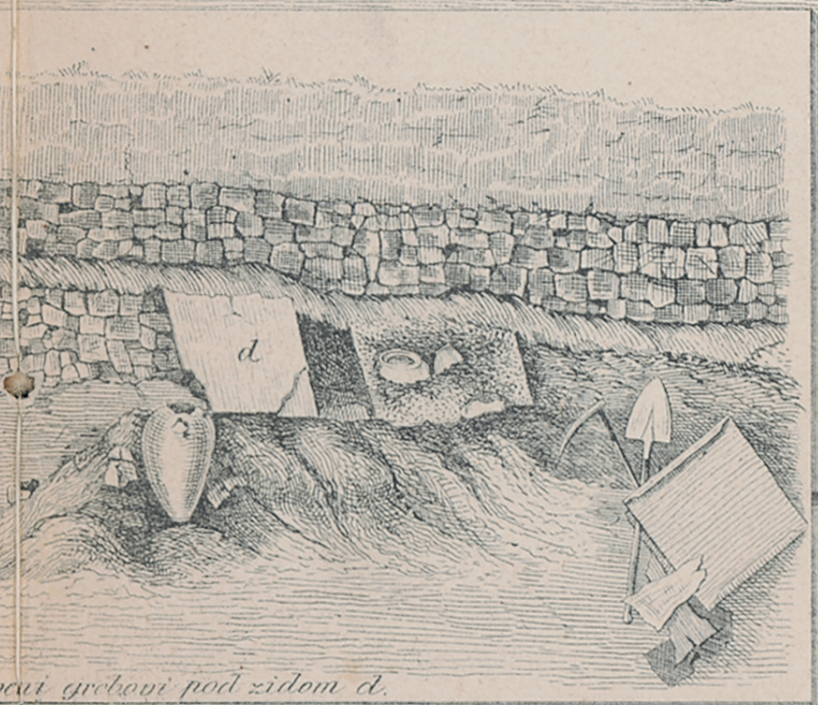

...ci grobovi pod zidom d.

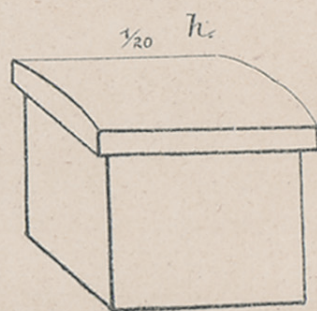

Sveći met = 1 cm

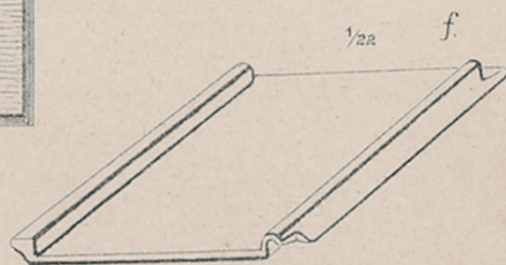



Inv. G. Alenche Ingrès

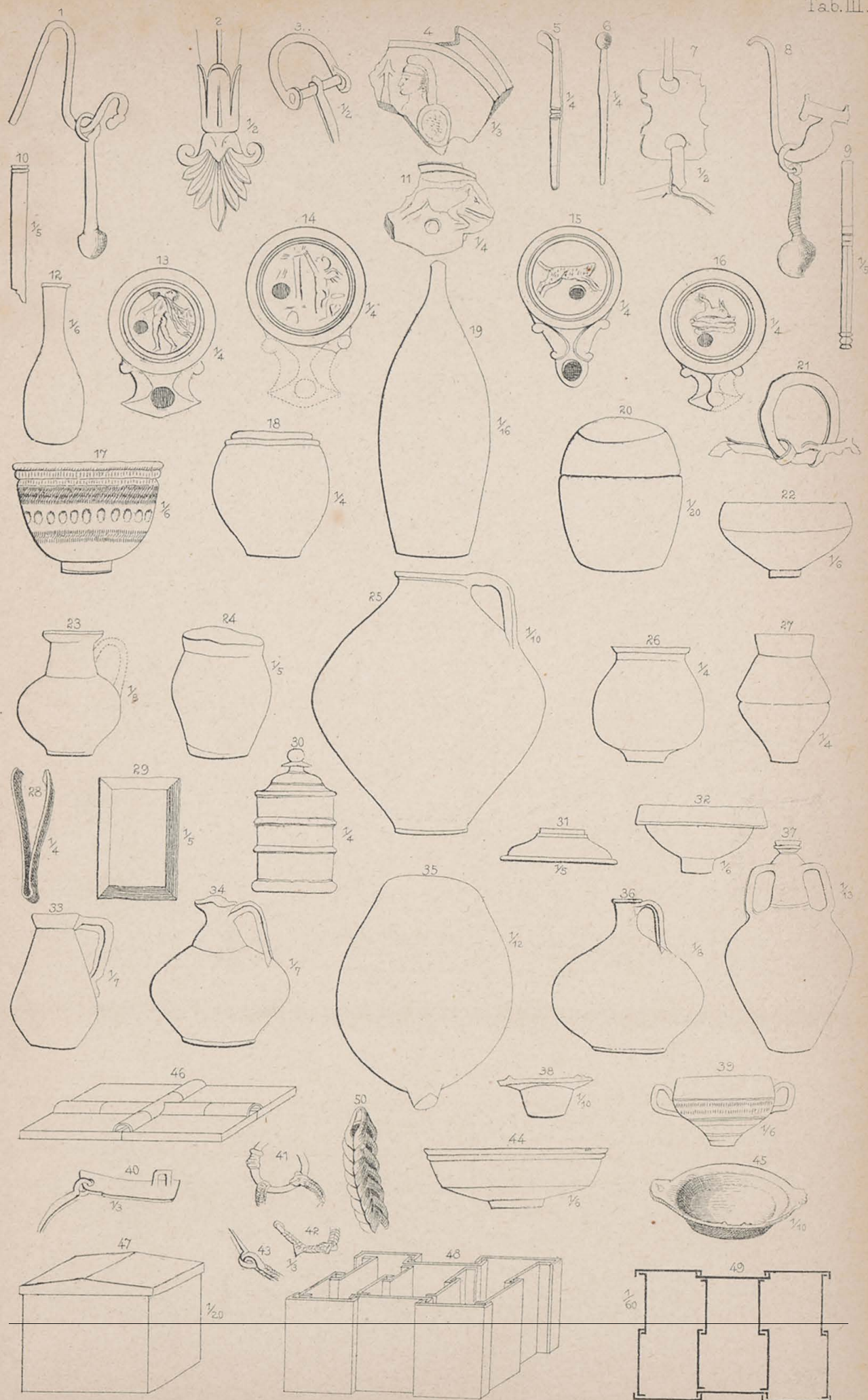

Tab. IV.

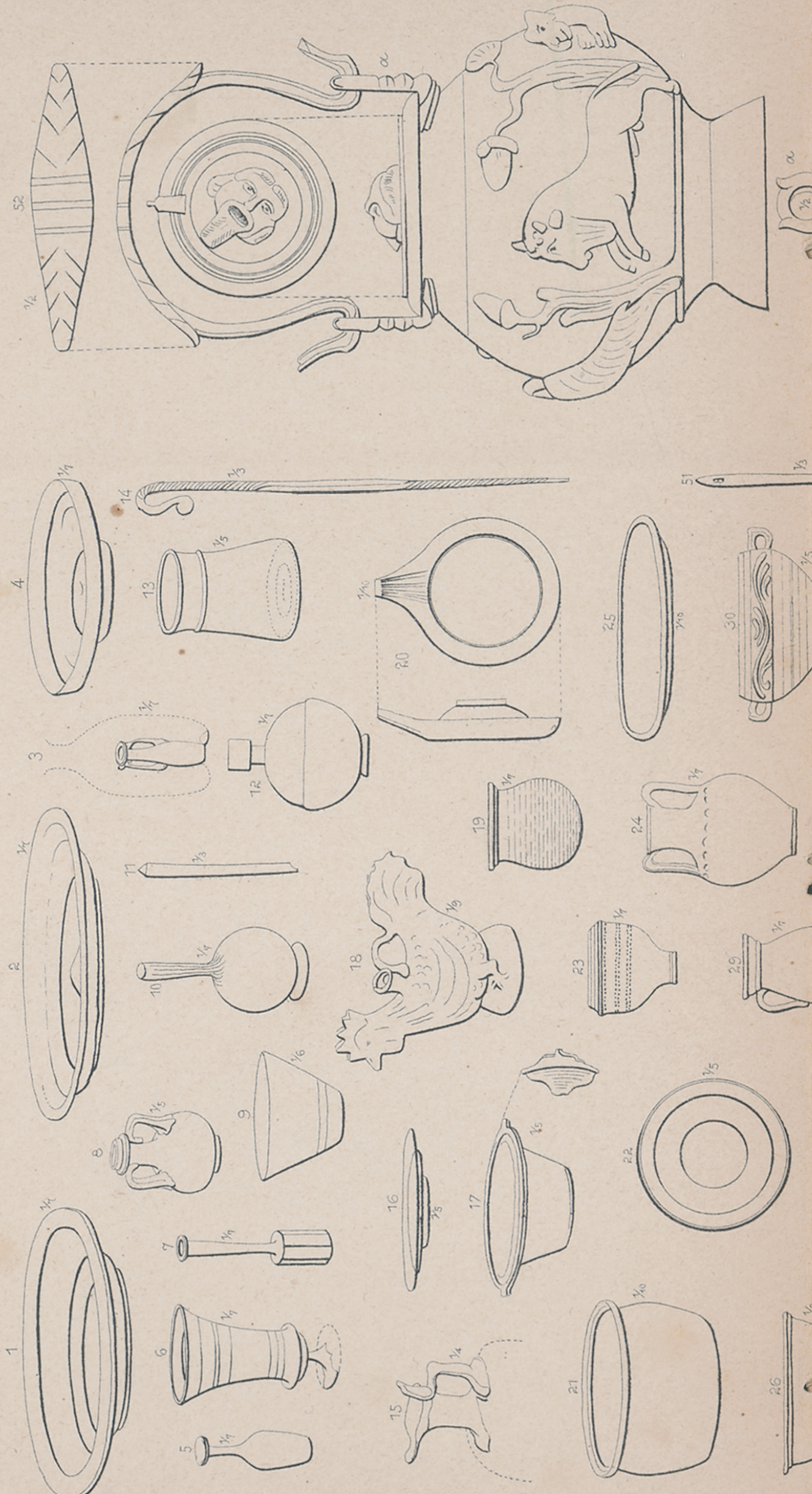

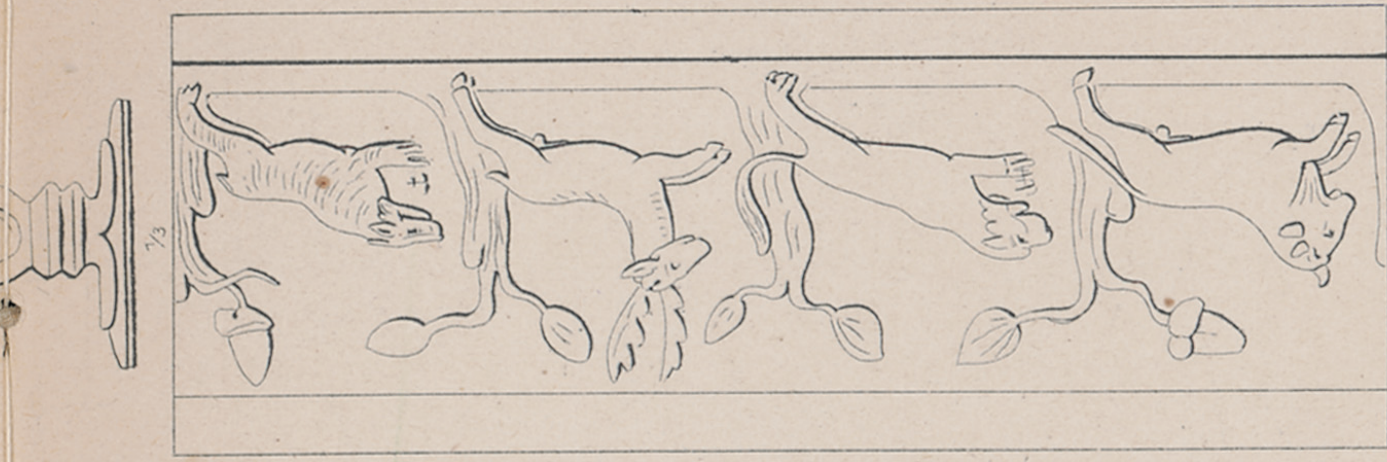

Tit. C. Albrecht Zagreb.

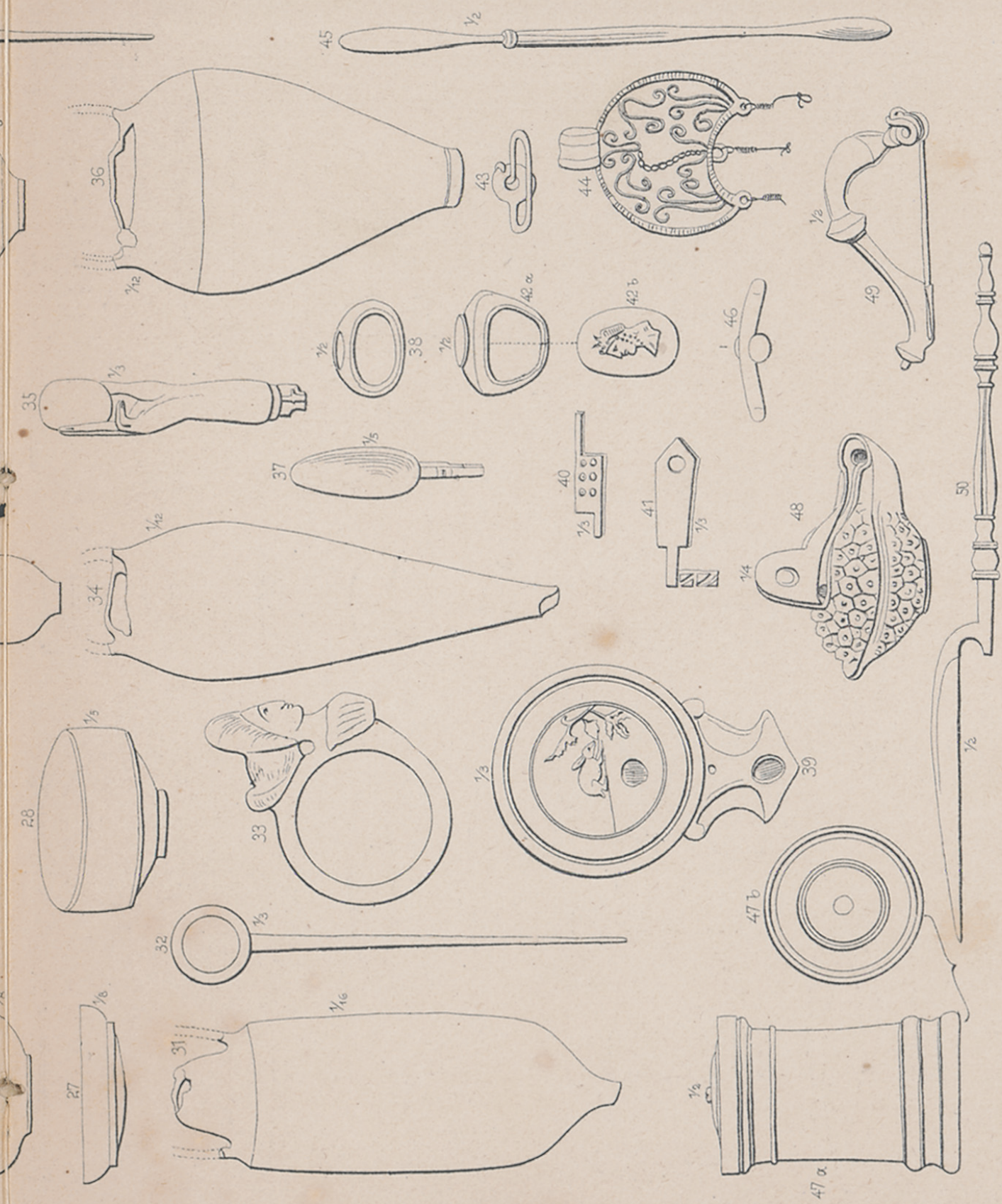

Irena Lazar

Staklo iz rimske nekropole u Bakru

The Glass from the Roman Cemetery in Bakar

Arheološki muzej u Zagrebu je tijekom svog dugogodišnjeg postojanja sakupio raznovrsno arheološko gradivo sa šireg područja današnje Hrvatske. Nažalost, veliki je dio građe ostao bez točnih podataka o nalazištu, a u nekim su primjerima uništene i cijele grobne jedinice koje na osnovi starih objava i zapisa više nije moguće rekonstruirati. Takav je primjer opsežna i dobro očuvana staklena građa iz rimske nekropole u Bakru (*Volcera?*), koju je Muzej prikupio potkraj 19. stoljeća (vidi Gregl str. 11)¹. Iako staklo iz bakarske nekropole možemo samo tipološki prikazati, unatoč svemu, njegova nam raznolikost i dobra očuvanost pružaju dovoljno podataka vrijednih za cjelovitu monografsku objavu. Omogućuje nam pogled u vrijeme ranih rimskih naselja na sjevernoj jadranskoj obali, njihove trgovačke veze s talijanskim teritorijem i sredozemnim područjem, te gospodarsku sliku ograničenog prostora u vrijeme procvata ranog carstva.

Očuvano staklo iz grobova u Bakru gotovo u cijelosti pripada slobodno puhanim proizvodima. Posuđe puhanu u kalup nije očuvano, izuzev nekoliko ukrasa i pečata na dnu koji su nastali u otvorenim jednodijelnim kalupima kada je osnovni oblik posude već bio napuhan i oblikovan. Građu smo podijelili u tri veće cjeline – stolno posuđe, posuđe za pohranu i kozmetičko posuđe.

¹ Srdačno zahvaljujem kolegi dr. Zoranu Greglu koji mi je ponudio suradnju pri obradi i objavi građe iz Bakra. Posebice zahvaljujem direktoru Arheološkog muzeja u Zagrebu, gospodinu Anti Rendić-Miočeviću za razumijevanje i potporu na projektu i svim suradnicima muzeja koji su pripomogli izdavanju ove monografije.

The Archaeological Museum in Zagreb has acquired diverse archaeological material from a broad area of present-day Croatia during its lengthy existence. Unfortunately, a large part of the material lacks exact data about the site of discovery, and in some cases entire grave units have been destroyed, which can no longer be reconstructed on the basis of earlier publications and records. One such example is the extensive and well preserved glass material from the Roman cemetery of Bakar (*Volcera?*), acquired by the museum at the end of the 19th century (see Gregl pp. 11).¹ Although the glass from the Bakar cemetery can only be presented in typological terms, nonetheless its diversity and good state of preservation offer sufficient data to be worth publishing in monographic form. The glass collection provides insight into the period of the early Roman settlements along the northern Adriatic coast, their trading contacts with the Italic lands and the Mediterranean region, and an economic perspective of a limited area in the prosperous period of the early Empire.

The preserved glass from the Bakar graves consisted almost entirely of free-blown products. Mould-blown vessels have not been preserved, with the exception of several decorations and stamps, which were created in open single-part moulds when the basic form of the vessel had already been blown and formed. The material has been classified into three main groups – tableware, storage vessels,

¹ I would like to sincerely thank my colleague Dr. Zoran Gregl, who offered me the chance to take part in the analysis and publication of the glass material from Bakar. I would particularly like to thank the director of the Archaeological Museum in Zagreb, Ante Rendić-Miočević, for his forbearance and support of the project, and also all the staff of the museum that contributed to the publication of this monograph.



Sl. 1 Posuđe od kobaltno plavog stakla – tanjur i dva balzamarija | **Fig. 1** Vessels made of cobalt blue glass – plate and two balsamaria (Inv. br. / Inv. no. 11859, 11016, 11087)

Stolno posuđe

U skupinu stolnog posuđa uvrstili smo tanjure, zdjele i zdjelice, čaše i vrčeve koji su se ponajčešće upotrebljavali za služenje na stolu, serviranje vina i vode te drugih prehrambenih tekućina.

Tanjuri

Tanjuri čine donekle opsežnu skupinu građe prema količini i obliku. Riječ je o posudi raširenoj u brojnim inačicama u rimskom razdoblju, u kojem su je upotrebljavali za donošenje hrane na stol kao i za njezino serviranje (sl. 1). Tanjuri su opredijeljeni kao posuđe čiji je promjer nekoliko puta veći od visine posude (npr. 1:5 ili 1:7), a visina ne prelazi 4 cm.

U toj skupini najjednostavniji oblik je tanjur bez nožice sa cjevasto svinutim rubom od kobaltnoplavog stakla (t. 1: 1; sl. 1; oblik Is 46a).¹ Dno je gotovo ravno i u sredini blago zadebljano, koje prelazeći u ravne stijenke završava cjevastim, prema van svinutim rubom. Riječ je o posudi koja je izrađena od prirodno modrozelenkastog ili obojenog stakla intenzivnih nijansi (plavo, tamnozeleno, jantarno). U grobovima je tom obliku često pridodana polukuglasta zdjelica vrste Is 44a ili zdjelice oblika Is 42/43 i 41 koje također nalazimo među građom iz Bakra (vidi t. 4).

Oblik tih tanjura je čest među građom sjeverne i srednje Italije, često ga srećemo i u Emoni, te u Hrvatskoj, primjerice u Zadru. S. Biaggio Simona napominje vjerojatnost proizvodnje tog oblika tanjura u više talijanskih radionica sjeverne Italije, točnije na području Verbana.² Vrijeme najintenzivnije proizvodnje tog oblika je sredina i druga pol. 1. st.; u grobovima se nisu pojavljivali prije 30. god., zapravo najučestaliji su bili između 50. i 100. god., iako ih u pojedinim grobovima nalazimo kao prilog još i na početku 2. st.³

U drugu skupinu svrstavamo tanjure na izvučenu (ili nataljenu) prstenastu nogu⁴ s ravnim stijenkama i zataljenim rubom (t. 1: 2–4), jedan na stijenci ima nataljenu nit stakla (t. 1: 4). Oblik Is 47 je moguće usporediti s građom sa Magdalensberga,⁵ Ticina,⁶

¹ Oblici po tipologiji Clasine Isings (1957) navedeni su u skraćenom obliku Is 46, a zbog poznate tipologije bez citiranja stranica za pojedine oblike; Lazar 2003, 64.

² Biaggio Simona 1991, 50.

³ Biaggio Simona 1991, 51.

⁴ Lazar 2003, 64, 1.2.1.

⁵ Czurda-Ruth 1979, 86.

⁶ Biaggio Simona 1991, 54.

Tableware

The tableware group contains plates, bowls, beakers, and jugs, which were primarily used for serving food, and wine, water, and other beverages.

Plates

Plates represent a fairly extensive group of material in terms of quantity and form. This is a vessel type that was widely used in numerous variants in the Roman period, used for bringing food to the table as well as serving it (fig. 1). Plates are defined as vessels whose diameter is several times greater than the height of the vessels (for instance 5:1 or 7:1), with a height of up to 4 cm.

The simplest form in this group is a plate with a flat base and a tubular rim made of cobalt blue glass (pl. 1: 1; fig. 1; form Is 46a).¹ The base is almost entirely flat and slightly thickened in the middle, merging into straight walls that end in a tubular rim turned outwards. This was a vessel that could be made of naturally blue-green glass or from coloured glass of intensive nuances (blue, dark green, amber). These vessels are often accompanied in graves by hemispherical bowls of form Is 44a or bowls of form Is 42/43 and 41, which can also be found among the material from Bakar (see pl. 4).

The form of these plates is common among the material from northern and central Italy, and can also often be found in Emona (Ljubljana), and at Zadar, for example, in Croatia. S. Biaggio Simona mentions that this form of plate was probably produced at several workshops in northern Italy, specifically in the region of Verbana.² The period of the most intensive production of these plates was the middle and second half of the 1st century; they do not appear in graves prior to AD 30, and are most widely distributed between AD 50 and 100, although in individual graves they can also be found as grave goods even at the beginning of the 2nd century.³

The second group consists of plates with a tubular base ring⁴ with straight walls and a fire-rounded rim (pl. 1: 2–4), one with glass trail on the walls (pl. 1: 4). The form Is 47 can be compared with material

¹ The forms according to the typology of Clasina Isings (1957) are cited in the abbreviated form (Is 46), without citation of the relevant pages for individual forms as the typology is so widely known and accepted; Lazar 2003, 64.

² Biaggio Simona 1991, 50.

³ Biaggio Simona 1991, 51.

⁴ Lazar 2003, 64, 1.2.1.

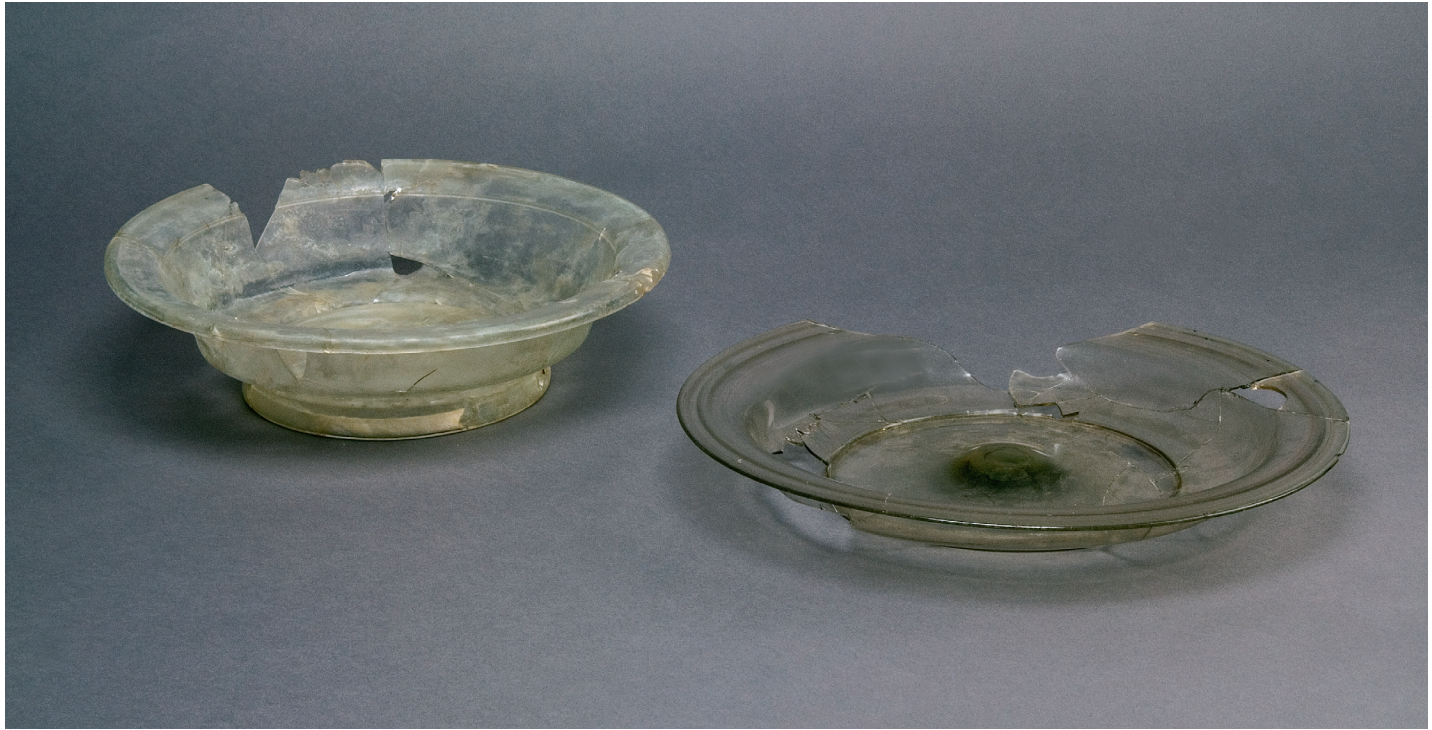

Sl. 2 Tanjur i zdjela većih dimenzija | Fig. 2 Large plate and a bowl (Inv. br. / Inv. no. 11105, 11104)

Emone⁷ i Zadra.⁸ Proizvodno središte tog oblika posude možemo potražiti u Akvileji, odakle su proizvodi bili rašireni po širem području sjeverne Italije, Jadrana i Magdalensberga, a nalazimo ih i u središnjoj Italiji te na germanskom području.⁹

Tanjur s dvostruko izvučenom prstenastom nogom i cjevasto savijenim rubom (Is 48) ima blago ukošene stijenke, a noga na prijelazu iz stijenki u odebljano dno izrađena je u obliku većeg nabora koji služi kao noga (t. 1: 5), unutrašnja noga je manja i jednostavno izvučena iz dna. Primjere poznajemo iz Emone¹⁰ i Zadra,¹¹ Magdalensberga¹² i sjeverne Italije (Muralto, Torino). Oblik nije znatnije rasprostranjen možda stoga što su ga istisnuli jednostavno izrađeni oblici iz lokalnih radionica. Prema nalazima sa Magdalensberga, moguće je zaključiti kako je taj tip tanjura bio u upotrebi već u kasnoaugustovsko vrijeme, a većina ostalih nalaza potječe iz 1. stoljeća. Nalaze s područja Ticina Biaggio Simona na osnovi materijala točnije svrstava u treću četvrtinu 1. stoljeća.¹³

Najveću grupu čine tanjuri s prstenastom nogom i horizontalno razgrnutim rubom (t. 2, 3). Široko razgrnut rub pokatkad je profiliran i na donjoj strani odebljan (t. 2: 3, 4), u nekoliko je primjera na gornjoj strani ukrašen sitnim urezima u obliku zrna riže (t. 2: 1, 2, 4). Prstenasta noga je niska, dno je u sredini odebljano i udubljeno (sl. 2 – desno). Oblik je srodan formi Is 45.

Na području Ticina oblik se pojavio u drugoj pol. 1. st. i u prvoj pol. 2. st., nalazi iz Pompeja i Aoste su pak iz 1. st.¹⁴ Proizvode s profiliranim rubom, odnosno rebrom na donjoj strani i ukrasom rižinih zrna na gornjoj s područja sjeverne Italije (oblik Is 42a)

from Magdalensberg,⁵ Ticino,⁶ Emona,⁷ and Zadar.⁸ The production center for this form can be sought in Aquileia, from where the products spread throughout the broader area of northern Italy, the Adriatic, and the eastern Alps, and they can also be found in central Italy and in the Germanic regions.⁹

A plate with a double tubular base ring and tubular rim (Is 48) has slightly slanted walls; the base ring at the transition from the wall to the thickened base was made in the form of a large fold serving as a foot (pl. 1: 5), while the interior base ring was smaller and simply drawn away from the base. Analogies are known from Emona,¹⁰ Zadar,¹¹ Magdalensberg,¹² and northern Italy (Muralto, Torino). The form is not widely distributed, perhaps because it was replaced by more simply produced forms from local workshops. On the basis of the finds from Magdalensberg, it can be concluded that this type of plate was already in use in the late Augustan period, while the rest of the other finds come from the 1st century. The finds from the area of Ticino were more specifically classified to the third quarter of the 1st century by Biaggio Simona.¹³

The largest group consists of plates with a tubular base ring and a horizontally everted rim (pl. 2, 3). The widely splayed rim is sometimes profiled and thickened on the lower side with a ridge (pl. 2: 3, 4), and several examples are decorated on the upper side with tiny incisions shaped like a rice grain (Pl. 2: 1, 2, 4). The foot is low, and the base is thickened and concave in the centre (fig. 2 – right). The form is similar to Is 45.

This form appeared in the Ticino area in the second half of the 1st century and the first half of the 2nd, while the finds from Pompeii

⁷ Plesničar Gec 1972, t. 133: 11.

⁸ Ravagnan 1994, 227, no. 454, 455.

⁹ Biaggio Simona 1991, 54.

¹⁰ Plesničar Gec 1972, 253, gr. 744.

¹¹ Trasporenze 1998, 186, no. 177, 179.

¹² Czurda-Ruth 1979, 89.

¹³ Biaggio Simona 1991, 52.

¹⁴ Biaggio Simona 1991, 55.

⁵ Czurda-Ruth 1979, 86.

⁶ Biaggio Simona 1991, 54.

⁷ Plesničar Gec 1972, pl. 133: 11.

⁸ Ravagnan 1994, 227, nos. 454, 455.

⁹ Biaggio Simona 1991, 54.

¹⁰ Plesničar Gec 1972, 253, gr. 744.

¹¹ Trasporenze 1998, 186, nos. 177, 179.

¹² Czurda-Ruth 1979, 89.

¹³ Biaggio Simona 1991, 52.



Sl. 3 Tanjuri | Fig. 3 Plates (Inv. br. / Inv. no. 11027, 11109, 11021)

prikupio je Tarpini i nazvao ih varijanta *Limburg 1971*.¹⁵ Utvrdio je da je na području padske nizine, a posebno na njezinu južnom dijelu te na području Modene, zapažena velika koncentracija predmeta toga oblika.¹⁶ O proizvodnim središtima još nije moguće zaključivati, nalazi su datirani u 2. stoljeće, neki pak u drugu pol. 1. st. B. Rützi taj oblik u Augstu opredjeljuje kao AR 83.¹⁷ Nalazištima iz sjeverne Italije tako možemo dodati donekle brojne nalaze iz Slovenije (Simonov zaliv, Piran, Ribnica na Dolenjskem – neobjavljena građa) i Hrvatske.

Tanjur s rebrastom aplikacijom na rubu (t. 3: 2)¹⁸ dekoracijom se izdvaja iz svoje skupine i pripada proizvodima koji su prvenstveno bili rašireni na sredozemnom području. Tu se među staklarskim središtima rimskog doba isticao Cipar i upravo tim radionicama pripisuju se tanjuri i zdjelice s ukrasom rebrastih aplikacija na rubu.¹⁹ Bakru najbliže usporedbe nalazimo u Italiji, među nalazima groblja u Albengi (*Albigaunum*), gdje su tanjuri toga oblika datirani na završetak 1. i početak 2. stoljeća;²⁰ jednaka datacija zna se za tanjur iz groba u Buzetu;²¹ nalazi iz Slovenije (Unec, Logatec) su, sudeći prema grobnim cjelinama, malo mlađi. Datirani su u sredinu i djelomice drugu pol. 2. st.²²

and Aosta are from the 1st century.¹⁴ Examples with a profiled rim or a ridge on the underside and a rice grain decoration on the upper side (form Is 42a) from the region of northern Italy were gathered by Tarpini, who called them the *Limburg 1971* variant.¹⁵ He established that in the area of the Po lowlands, and particularly their southern part, as well as in the region of Modena, a major concentration of objects of this form could be noted.¹⁶ No conclusions can yet be made about production centres, and the finds are dated to the 2nd century, and some to the second half of the 1st century. B. Rützi defined this form at Augst as AR 83.¹⁷ The fairly numerous finds from Slovenia (Simonov zaliv, Piran, Ribnica na Dolenjskem – unpublished material) and Hrvatske can be added to those from the northern Italian sites.

The plate with a ribbed applied bands on the rim (pl. 3: 2)¹⁸ stands out from its group in terms of the decoration and can be classified among products that were primarily widespread in the Mediterranean region. Cyprus was prominent for its glass-making centres in the Roman period, and plates and vessels with a decoration of ribbed applied bands or handles on the rim are attributed specifically to these workshops.¹⁹ The closest analogies to Bakar can be found in Italy, among the finds from the cemetery at Albenga (*Albigaunum*), where plates of this type were dated to the end of the 1st century and beginning of the 2nd century,²⁰ and an identical date was given for plate from a grave at Buzet,²¹ while the finds from Slovenia (Unec, Logatec) are somewhat later on the basis of the grave units, and are dated to the middle and part of the second half of the 2nd century.²²

¹⁵ Tarpini 2000, 96.

¹⁶ Tarpini 2000, 97, Fig. 2, 3.

¹⁷ Rützi 1991, 86.

¹⁸ Lazar 2003, 67, oblik 1.3.2.

¹⁹ Whitehouse 1997, 75.

²⁰ Massabò 1999, 64–65.

²¹ Girardi Jurkić, Džin 2003, 167, br. 288.

²² Lazar 2003, 67.

¹⁴ Biaggio Simona 1991, 55.

¹⁵ Tarpini 2000, 96.

¹⁶ Tarpini 2000, 97, fig. 2, 3.

¹⁷ Rützi 1991, 86.

¹⁸ Lazar 2003, 67, form 1.3.2.

¹⁹ Whitehouse 1997, 75.

²⁰ Massabò 1999, 64–65.

²¹ Girardi Jurkić, Džin 2003, 167, no. 288.

²² Lazar 2003, 67.

Zdjele i zdjelice

Zdjele i zdjelice koje susrećemo u antici od različitih su materiala; od stakla, keramike do plemenitih metala; u rimsko su se vrijeme upotrebljavale za posluživanje različitih vrsta hrane, tekućina i umaka. Većinom su ih upotrebljavali na stolu pri serviranju jela, a njihov oblik i veličina prilično su varirali.

Kao grobni prilog zdjelice su općenito češće od tanjura ili čaša, također su više puta priložene u skupini, kao set ili servis (primjer Emona, gr. 744).²³ Njihova brojnost uostalom potvrđuje i njihovu široku uporabu u rimskoj svakodnevici pri pripravljanju i posluživanju hrane.

U skupinu bakarskih zdjelica ubrajamo proizvode manjih i većih dimenzija koje s obzirom na očuvanost, ugrubo možemo podijeliti na četiri skupine: posude s konusnim (Is 41) i polukuglastim stijenkama (Is 42), posude s visećim rubom na visokoj nozi, te samo jedan proizvod s figuralnim ukrasom.

Četiri zdjelice (t. 4: 1–4) pripadaju obliku sa stijenkama nagnutim prema van i izvučenim rubom (Is 41b).²⁴ U cijelosti uzevši, taj je oblik zdjelice vrlo raširen. Najviše nalaza poznajemo iz Italije i njoj bliskih nalazišta. Izrađene su od modrozelenkastog ili intenzivno obojenog stakla, osobito tamno plavoga. Nalazi iz Bakra također su izrađeni od modrozelenkastog i obojenog stakla (sl. 4).

Najraniji nalaz toga oblika zdjelice poznajemo sa Magdalensberga; datirana je u augustovsko doba.²⁵ Među brojnim drugim primjerima spominjemo nalaze iz Pompeja, Herkulanuma (Scattozza Höricht 1986, forma 10, 35) i Ostije, gdje se pojavljuju u slojevima datiranim u vrijeme Domicijana i Trajana.²⁶ Drugoj pol. 1. st. pripadaju i nalazi iz Bologne.²⁷ Nalazi iz kantona Ticino u Švicarskoj datirani su u drugu pol. 1. i još na početak 2. st.²⁸ Nalazi sa slovenskih nalazišta (Dobova, Emona) pripadaju flavijskom razdoblju,²⁹ a pojavljuju se još u 2. stoljeću (Miklavž pri Mariboru).³⁰ U Hrvatskoj je oblik poznat iz Siska³¹ i Zadra.³²

Skupina zdjelica s vodoravno izvučenim rubom (t. 4: 5–10) je s prethodno navedenim prilično srodna; razlika je ponajprije u široko razgrnutom i vodoravnom obodu (Is 42a, Is 43). Oblik odražava istodobnost uporabe i međusobne utjecaje keramičkih proizvoda – zdjelica oblika Drag 35. Posude koje su većinom izrađene od prirodno obojenog stakla variraju veličinom, od manjih do prilično velikih proizvoda s promjerom do 17 cm (sl. 5).

Taj oblik posudice je donekle raširen; česti su ponajprije na nalazištima sjeverne Italije, srednje i zapadne Europe, a pojedinačne primjere nalazimo na Cipru i u Tripolitaciji.³³ Oblik nalazimo i među gradivom iz Pompeja i Herkulanuma. Tu su pronađene sa ostacima materijala za transport.³⁴ Nalazi sa Magdalensberga upućuju da su se tamo pojavile od sredine 1. stoljeća i nadalje, najčešće od 70. do 120/130. godine.³⁵

²³ Plesničar Gec 1972, t. 207.

²⁴ Lazar 2003, 72, oblik 2.4.1.

²⁵ Czurda-Ruth 1979, 87, no. 653

²⁶ Scattozza Höricht 1986, 35–36, forma 10.

²⁷ Meconcelli Notarianni 1979, 40, no. 24.

²⁸ Biaggio Simona 1991, 78–80.

²⁹ Petru 1969, 14.

³⁰ Pahič 1969, 113.

³¹ Wiewegh 2003, t. 34: 4

³² Ravagnan 1994, 188, no. 371–374.

³³ Biaggio Simona 1991, 81.

³⁴ Scattozza Höricht 1986, 35.

³⁵ Czurda-Ruth 1979, 57–58.

Bowls and cups

The bowls and cups that can be found in antiquity were made of various materials, from glass and pottery to noble metals, were used in the Roman period to serve various kinds of food, liquids, and sauces. Most were used as for serving food at table, and their form and size varied considerably.

Bowls in general are more common as grave goods than plates or beakers, and are also more commonly placed in a group as a set (for example, Emona, gr. 744).²³ Their great quantity further confirms their broad use in Roman everyday life in preparing and serving food.

The bowls from Bakar include products of large and small dimensions, which in terms of preservation can be roughly classified into four groups: vessels with conical (Is 41) and globular walls (Is 42), vessels with a hanging rim on a tall foot, and only one example with figural decoration.

Four bowls (pl. 4: 1–4) belong to the form with turned-out walls and an everted rim (Is 41b).²⁴ Taken as a whole, this form of bowl is very widespread. The greatest number of finds come from Italy and sites nearby. They were made from blue-green or coloured glass, mostly dark blue. The finds from Bakar were also made of blue-green and coloured glass (fig. 4).

The earliest find of this type of bowl is known from Magdalensburg and is dated to the Augustan period.²⁵ Numerous other examples include finds from Pompeii, Herculaneum and Ostia, where they appear in strata dated to the reigns of Domitian and Trajan.²⁶ Finds from Bologna also belong to the second half of the 1st century.²⁷ Finds from the canton of Ticino in Switzerland are dated to the second half of the 1st and carry on into the beginning of the 2nd century.²⁸ Finds from Slovenian sites (Dobova, Emona) belong to the Flavian period,²⁹ and further appear in the 2nd century (Miklavž near Maribor).³⁰ The form is known in Croatia from Siscia³¹ and Zadar.³²

The group of bowls with horizontally everted rims (pl. 4: 5–10) is fairly closely related to the above group, the difference primarily being in the widely out-turned and horizontal rims (Is 42a, Is 43). The form reflects the contemporaneous use and mutual influence of pottery products – small bowls of form Drag 35. The vessels, mostly made from naturally coloured glass, vary in dimensions from small to fairly large examples with diameters up to 17 cm (fig. 5).

This form of vessel is fairly widespread, common above all at sites in northern Italy, central, and western Europe, while individual examples can be found on Cyprus and at Tripolitania.³³ The form can also be found among the material from Pompeii and Herculaneum. They were found there with remains of material for transport.³⁴ The finds from Magdalensburg indicate that they appeared there from around the middle of the 1st century and onwards, while they were most common from 70 to 120/130 AD.³⁵

²³ Plesničar Gec 1972, pl. 207.

²⁴ Lazar 2003, 72, form 2.4.1.

²⁵ Czurda-Ruth 1979, 87, no. 653

²⁶ Scattozza Höricht 1986, 35–36; form 10.

²⁷ Meconcelli Notarianni 1979, 40, no. 24.

²⁸ Biaggio Simona 1991, 78–80.

²⁹ Petru 1969, 14.

³⁰ Pahič 1969, 113.

³¹ Wiewegh 2003, pl. 34: 4

³² Ravagnan 1994, 188, nos. 371–374.

³³ Biaggio Simona 1991, 81.

³⁴ Scattozza Höricht 1986, 35.

³⁵ Czurda-Ruth 1979, 57–58.



Sl. 4 Zdjelice od obojenog stakla | Fig. 4 Bowls made of coloured glass (Inv. br. / Inv. no. 11014, 11015, 11016)



Sl. 5 Zdjelice | Fig. 5 Bowls (Inv. br. / Inv. no. 11017, 11020, 11812)

U Švicarskoj, u kantonu Ticino, taj se oblik zdjelice pojavio počev od flavijskog razdoblja nadalje. Njihova uporaba potrajala je cijelo drugo stoljeće, a pojedini su primjerci poznati s početka 3. stoljeća.³⁶ U Augstu su ti proizvodi (AR 80) postali česti tek u 2. stoljeću, a sezali su i u treće.³⁷ Posudice iz Slovenije (Miklavž, Cerknica, Emona) prema grobnim cjelinama pripadaju u 2. stoljeće.³⁸

Mlađa inačica tog oblika ima izrazito profiliran rub i na gornjoj strani ukras u obliku rižinih zrna (t. 4: 7–10). Kao i tanjur, opredijeljena je kao varijanta *Limburg 1971*.³⁹ Vrlo su raširene na nalazištima sjeverne i središnje Italije, gdje su u 2. stoljeću bile i najraširenije,⁴⁰ u Augstu su u upotrebi uglavnom u 2. stoljeću, a javljale su se i na početku trećega.⁴¹ U Sloveniji su za sada poznate samo među građom Simonova zaljeva u Izoli i Ribnici na Dolenjskem (neobjavljeno), gdje s obzirom na stratigrafiju nalazišta, pripadaju u 2. stoljeće.⁴²

Jedina posudica s rebrastom aplikacijom na rubu je (t. 4: 6), kao i već analizirani tanjur s jednakim ukrasom, proizvod sredozemnih radionica, najvjerojatnije ciparskih.⁴³ Obje posude prema obliku i detaljima ukrasa odražavaju formu stolnog srebrnog posuđa koje je u tom razdoblju bilo u upotrebi i koje poznajemo primjerice iz Pompeja (npr. Casa del Menandro), datiranog u sredinu 1. stoljeća.⁴⁴

Na Cipru se takve staklene zdjelice javljaju u kontekstima datiranim na kraj 1. stoljeća i u 2. stoljeću.⁴⁵ U Europi nalazimo usporedbe koje doduše nisu brojne, u Švicarskoj, na Kreti, ali i u Izraelu i Alžiru. Na tim su se nalazištima ti proizvodi pojavili počev od druge pol. 1. st. i u 2. st.⁴⁶ Usporedbe s hrvatskim nalazištima potječu iz Zadra,⁴⁷ iz Slovenije pak poznajemo primjerak iz Cerknice koji, gledajući na ostale priloge, pripada u drugu pol. 1. odnosno na početak 2. st.⁴⁸

Dvije malo veće zdjele (t. 5: 1, 2) moguće je usporediti s oblikom Is 87. Stoje na izvučenoj visokoj prstenastoj nozi, obod je širok i nagnut prema van a rub je razgrnut prema van i nadolje (sl. 2 desno). Staklo je kvalitetno, dekolirano, oblik prvenstveno podsjeća na u kalupu izrađene proizvode od bezbojnog stakla s urezanim facetiranim ukrasom, koji su bili rašireni od flavijskog doba i nadalje (oblik Rützi AR 14).⁴⁹ Rijetke pojedinačne usporedbe posudama nalazimo u sjevernoj Italiji,⁵⁰ dok je znatno više usporedbi poznato sa Cipra,⁵¹ iz Karanisa u Egiptu,⁵² Hanite (Galileja)⁵³ i Troje (Portugal).⁵⁴ Vjerojatno je riječ o proizvodima istočnih radionica koji su bili izvoženi i u zapadni

In Switzerland, in the canton of Ticino, this form of bowl appeared from the Flavian period onwards. Their use continued throughout the entire 2nd century, and individual examples are known from the beginning of the 3rd century.³⁶ At Augst these products (AR 80) are common only in the 2nd century, and extend into the third.³⁷ The vessels from Slovenia (Miklavž, Cerknica, Emona) belong to the 2nd century on the basis of the grave units.³⁸

A later variant of this form has a distinctly profiled rim (with a ridge on the underside) and a decoration on the upper side in the shape of a grain of rice (pl. 4: 7-10). Like the plate of this type, it was defined as variant *Limburg 1971*.³⁹ They are very widespread at the sites of northern and central Italy, where they were most common in the 2nd century,⁴⁰ and at Augst primarily in the 2nd century, where they also appeared at the beginning of the 3rd century.⁴¹ In Slovenia so far they are known only among the material from Simonov zaliv in Izola and Ribnica na Dolenjskem (unpublished), where considering the stratigraphy they can be assigned to the 2nd century.⁴²

The only vessel with a ribbed applied band on the rim (pl. 4: 6), like the previously discussed plate with identical decoration, was a product of a Mediterranean workshop, most probably on Cyprus.⁴³ Both vessels, on the basis of the shape and details of the decoration, reflect a type of silver table vessel that was in use in that period and is known, for example, from Pompeii (e.g. Casa del Menandro), where it is dated to the middle of the 1st century.⁴⁴

Such glass bowls appear on Cyprus in contexts dated to the end of the 1st century and the 2nd century.⁴⁵ A few analogies can be found in Europe, in Switzerland, on Crete, and in Israel and Algeria. At those sites these products appear from the second half of the 1st century and in the 2nd century.⁴⁶ Comparative material from Croatian sites is known from Zadar,⁴⁷ while an example from Cerknica (Slovenia) can be assigned on the basis of the remaining grave goods to the second half of the 1st century and the beginning of the 2nd century.⁴⁸

Two somewhat larger bowls (pl. 5: 1, 2) can be compared with the form Is 87. They stand on a tall tubular foot, the rim is broad, while the rim edge is everted and overhanging (fig. 2 – right). The glass is of high quality, decoloured, and the form fairly reminiscent of products of colourless glass made in a mould with facet-cut decoration, which were widespread from the Flavian period onwards (Rützi form AR 14).⁴⁹ Rare individual analogies to the bowls can be found in northern Italy,⁵⁰ while larger amounts of comparative examples are known from Cyprus,⁵¹ Karanis in Egypt,⁵² Hanita

³⁶ Biaggio Simona 1991, 82.

³⁷ Rützi 1991, 83.

³⁸ Pahič 1969, 74; Urleb 1984, 312; Lazar 2003, 74.

³⁹ Tarpini 2000, 97.

⁴⁰ Tarpini 2000, 96, Fig. 2, 3.

⁴¹ Rützi 1991, 83.

⁴² Lazar 2003, 75.

⁴³ Whitehouse 1997, 75.

⁴⁴ Massabò 1999, 226, fig. p. 65, 74, tav. 30.

⁴⁵ Vessberg 1956, 196, Fig. 42: 16,17.

⁴⁶ Whitehouse 1997, 75.

⁴⁷ Ravagnan 1994, 193, no. 384–388.

⁴⁸ Urleb 1984, 312.

⁴⁹ Rützi 1991, 42.

⁵⁰ Massabò 1999, 77, 244, tav. 12: 5.

⁵¹ Vessberg 1952, 117, tav. II: 12–14.

⁵² Harden 1936, 110–111, no. 246–255.

⁵³ Barag 1978, 21, no. 39.

⁵⁴ De Alarcão 1981, 108, Fig. 6–9.

³⁶ Biaggio Simona 1991, 82.

³⁷ Rützi 1991, 83.

³⁸ Pahič 1969, 74; Urleb 1984, 312; Lazar 2003, 74.

³⁹ Tarpini 2000, 97.

⁴⁰ Tarpini 2000, 96, Fig. 2, 3.

⁴¹ Rützi 1991, 83.

⁴² Lazar 2003, 75.

⁴³ Whitehouse 1997, 75.

⁴⁴ Massabò 1999, 226, fig. p. 65, 74, pl. 30.

⁴⁵ Vessberg 1956, 196, fig. 42: 16,17.

⁴⁶ Whitehouse 1997, 75.

⁴⁷ Ravagnan 1994, 193, nos. 384–388.

⁴⁸ Urleb 1984, 312.

⁴⁹ Rützi 1991, 42.

⁵⁰ Massabò 1999, 77, 244, pl. 12: 5.

⁵¹ Vessberg 1952, 117, pl. II: 12–14.

⁵² Harden 1936, 110–111, nos. 246–255.

dio Rimskog Carstva, gdje nisu znatnije brojčano zastupljeni. Isingsova predlaže dataciju oblika u 2. stoljeće, na osnovi nekoliko novijih nalaza iz sjeverne Italije Biaggio Simona predlaže dataciju tih proizvoda u drugu pol. 2. st. i 3. st.;⁵⁵ na početak 3. stoljeća je također datirana posuda iz Albenge – *Albigaunum*.⁵⁶

Jedini primjer figuralno ukrašenog posuđa je plitka polukuglasta zdjela (t. 5: 3), izrađena od dekoloriranog stakla (sl. 6). Prvi put je crtež publicirala već V. Damevski u svom pregledu stakla iz Hrvatske.⁵⁷ Tijekom obrade materijala iz Bakra posuda je bila ponovno očišćena, slijepljena i restaurirana.⁵⁸ Zahvaljujući kvalitetnom postupku, sada je moguće na ukrasu prepoznati detalje, koji prije nisu bili vidljivi, odnosno prepoznatljivi. Posuda ima izvučen, ravno odrezan i izbrušen rub, stijenke su donekle konveksne, dno je zaokruženo. Vanjska strana ima urezani ukras koji je dobro vidljiv na unutrašnjoj strani posude. Ukras, kako ga vidimo na vanjskoj strani, ima u sredini medaljon ograničen s dvije dvojne linije koncentričnih krugova. Međuprostor ispunjavaju kratki urezi u obliku izduženih zrna riže. Zbog restauriranja figura u središtu medaljona nije sačuvana u cjelini ali je jasno prepoznatljiva. S obzirom na usporedbe, možemo zaključiti da je i tu prikazano poprsje muške figure okrenute nalijevo s konusnim pokrivalom, odnosno šešikom. Kovrčava kosa strši ispod ruba kape. Rub odjeće, pokrivala i lica prikazan je valovitom linijom izrađenom pomoću kotačića, a struktura kaputa, odnosno odijela, pojedinačnim dvojnim urezima. Pred licem je još vidljiva valovita uspravna linija i svinuta gravirana crta. Vjerojatno je to ribički štap (?), koji je moguće prepoznati i na ostalim sačuvanim posudama. Obrisi kape, odijela i djelomice lica ucrtani su poludugim širim linijama pomoću kotačića, a pojedini detalji, primjerice ukras pokrivala, odijela, kovrče i lice bili su ugrebeni ručno.

Izvan medaljona je prostor omeđen jednom dvojnog linijom, zapunjen crtežima četiri veće ribe različitih vrsta, što se vidi iz ukrasa. Sve ribe plivaju nadesno, jedna za drugom. Glavni potezi tih figura izvedeni su duguljastim linijama pomoću brusnog kotačića. Detalji na ribama bili su ugrebeni ručno. Ukras koji zorno prikazuje riblju vrstu je na dvije ribe izrađen dvojnog linijama, a na jednoj su ugrebene spiralne linije. U nekoliko su poteza naznačeni valovi na vodi.

Posuda je nedvojbeno bila namijenjena serviranju svježe hrane u znak dobrodošlice, što nalazimo uprizoreno na brojnim mozaicima i freskama.⁵⁹ Darovi mora, ponuđeni na posudi s motivom ribara i njegovim ulovom naglasili su gostoljubivost kuće i počastili istodobno gosta i domaćina koji se pohvalio svojim dragocjenim predmetom. Graveri na staklu su u rimsko doba, baš kao i slikari ili kipari, radili na osnovi predložaka, odnosno uzoraka. S graviranim linijama koje su izradili kovinskim malim brusnim kolom različitih oblika i tvrdoće, oblikovali su osnovne poteze, ručnim su urezima dodavali detalje, a jetkanim i mutnim površinama stvorili su igru svjetla i sjene umjesto boja. Razlike u kvaliteti izrade očuvanih proizvoda govore da su pojedine radionice vrhunski savladale svoj posao i da su bile sposobne stvoriti dojam trodimenzionalnosti na posudi.

(Galilea),⁵³ and Troja (Portugal).⁵⁴ These were probably products of eastern workshops that were exported to the western part of the Roman Empire, where they were not very common. Isings suggested dating this form to the 2nd century, while on the basis of several recent finds from northern Italy Biaggio Simona suggested a date in the second half of the 2nd century and in the 3rd century,⁵⁵ and a similar vessel from Albenga - *Albigaunum* was also dated to the beginning of the 3rd century.⁵⁶

The only example of a figurally decorated vessel is a shallow hemispherical bowl (pl. 5: 3), made of decoloured glass (fig. 6). A drawing of it was first published by V. Damevski in her survey of glass from Croatia.⁵⁷ While working on the material from Bakar, the vessel was again cleaned, glued, and restored.⁵⁸ Such a thorough procedure means that details of the decoration can now be perceived that were not visible or recognizable before. The vessel has a slightly everted, cut-off, and ground rim, the walls are somewhat convex, and the base is rounded. The exterior side has an engraved decoration that is quite visible on the interior side of the vessel. The decoration as seen from the outside consists of a medallion in the centre bordered by two double lines of concentric circles. The space between them is filled with short incisions in the shape of an elongated rice grain. Because of the restoration, the figure in the centre of the medallion is not preserved entirely, but it is clearly recognizable. Given the analogies, it can be concluded that a bust was depicted here of a male figure, turned to the left, with a conical head covering or cap. Curly hair extends below the edge of the cap. The edges of the clothing, cap, and face were delineated by a wavy wheel-ground line (groove), while the structure of the mantle or clothing was marked with individual double dashes. In front of the face are a still wavy upright line and a curved engraved line. This was probably a fishing rod (?), which can be recognized on the other preserved vessels. The outlines of the cap, clothing, and partially the face were grooved with broad oblong lines, while individual details such as the decoration of the cap, the clothing, the locks of hair, and the face were engraved by hand.

Beyond the medallion and its frame was an area bordered by a single double line, filled with engravings of four large fish, or more exactly three fish and a fish head. All of the fish are swimming clockwise, one after the other. The main outlines of these figures were formed by wheel-grinding in long lines. Details on the fish were incised by hand with a sharp point. A decoration that faithfully depicts the type of fish using double upright lines was present on two fish, while spiral lines were engraved on another. Several strokes were used to mark waves on the surface of the water.

The vessel was undoubtedly intended for serving fresh food as a welcome, as can be seen depicted on numerous mosaics and frescoes.⁵⁹ Gifts from the sea, offered on a vessel with a motif of a fisherman and his catch, emphasized the hospitality of the house while giving honour at the same time to the guests and the hosts, who could show off such a valuable object. Glass engravers in the Roman period, just like painters or sculptors, worked on the basis of patterns or models. With engraved lines made with small metal wheel grinders of various form and hardness, they shaped the basic outlines, adding details by hand, and etched and opaque sections created a

⁵⁵ Isings 1957, 104; Biaggio Simona 1991, 86.

⁵⁶ Massabò 1999, 77.

⁵⁷ Damevski 1976, 86, t. 14.

⁵⁸ Restauratorski rad na zdjeli i ostalom staklenome materijalu iz Bakra izvela je Zrinka Znidarčić.

⁵⁹ Stern 2001, 136.

⁵³ Barag 1978, 21, no. 39.

⁵⁴ De Alarcão 1981, 108, fig. 6-9.

⁵⁵ Isings 1957, 104; Biaggio Simona 1991, 86.

⁵⁶ Massabò 1999, 77.

⁵⁷ Damevski 1976, 86, pl. 14.

⁵⁸ The restoration work on the bowl and the other glass material from Bakar was performed by Zrinka Znidarčić.

⁵⁹ Stern 2001, 136.



Sl. 6 Zdjela sa figuralnim ukrasom | Fig. 6 Bowl with engraved figural decoration

Do danas je prema očuvanim predmetima s brušenim figuralnim i geometrijskim ukrasima moguće prepoznati i opredijeliti nekoliko skupina predmeta koji su pripadali pojedinim radionicama u razdoblju Rimskog Carstva. Takve radionice su vjerojatno djelovale tijekom vremena koje obuhvaća više generacija; najpoznatiji i kvalitetni proizvodi pristizali su iz ateljea u Rimu, Egiptu i Porajnju.

Na osnovi detalja izrade bakarske posude, utvrđujemo da je riječ o proizvodu koji pripada skupini koju je E. M. Stern opredijelila kao *Contour Groove Group*⁶⁰ i time odredila glavnu značajku tehnike ukrasa tih posuda. U nastavku ih duhovito naziva »*riblje posude*«. Velike i ukusne ribe prikazane su na svim poznatim primjercima posuda a po načinu ukrasa je bilo moguće na nekima čak odrediti i vrstu.⁶¹

Motiv je gotovo identičan kao na posudi iz zbirke Ernesto Wolf, koju objavljuje E. M. Stern.⁶² Figura je okrenuta u istom smjeru i ima gotovo jednako izrađeno i ukrašeno pokrivalo. Donji rub odjeće prikazan je jednakom valovitom linijom. Razlika je vidljiva u rasporedu riba koje na našoj posudi plivaju jedna za drugom. Šteta što je posuda iz Bakra donekle slabije očuvana i restaurirana; stoga su pojedini detalji nejasni. Srodan motiv poznajemo na dubokoj posudi iz zbirke u Corningu.⁶³

Dakako u toj maloj skupini proizvoda moguće je opaziti detalje u kvaliteti izrade, što znači da su, doduše, nastale u istoj radionici, iako ih nije izradio isti majstor. Motivi koji se ponavljaju na posudama te skupine iz dobro datiranih konteksta (kraj 2. i početak 3. stoljeća) srodni su ukrasu na keramici iz egipatske fajanse, datirane u prva dva stoljeća po Kr.⁶⁴ Među 19 proizvoda koji pripadaju toj skupini 12 ih je iz Egipta,⁶⁵ a po jedan i iz Hrvatske i Slovenije.⁶⁶ S obzirom na homogenost skupine, kada je riječ o kvaliteti stakla, kompoziciji ukrasa i značaju tehnike gravure, može se zaključiti da je riječ o proizvodima egipatske radionice koja je proizvodnju započela u drugoj pol. 2. st. i svoje je proizvode izvozila u Italiju, na jadransku obalu te na zapad.⁶⁷

Svakako da na osnovi usporedbe s posudom iz zbirke E. Wolf zaključujemo kako je u primjeru nalaza iz Bakra riječ o proizvodu s identičnim figuralnim motivom koji je također nastao u Egiptu, vjerojatno i u istoj radionici.⁶⁸ Posuda je datirana u kasno 2. stoljeće.

play of light and shadow in place of colours. The differences in the quality of the workmanship of the preserved examples indicate that individual production centres brilliantly carried out their tasks and were capable of creating a three-dimensional effect on the vessel.

To the present it was possible on the basis of the preserved material with wheel-cut figural and geometric decoration to recognize and distinguish several groups of objects that belonged to individual workshops in the period of the Roman Empire. Such workshops were probably active through several generations, and the most famed and highest quality products came from ateliers in Rome, Egypt, and the Rhine valley.

Details of the workmanship of the vessel from Bakar enable confirmation that this was a product belonging to the group that E. M. Stern classified as the '*Contour Groove Group*',⁶⁰ with this defining the main characteristic of the technique of decorating such vessels. In the further text they were also wittily called »fish bowls«, as large and tasty fish were depicted on all known examples of such vessels, and according to the manner of decoration it was even possible to determine the species of some.⁶¹

The motif is almost identical to that on a vessel from the Ernesto Wolf collection, which was published by E. M. Stern.⁶² The figure is turned in the same direction, and has an almost identically formed and decorated head covering. The lower edge of the clothing is depicted with an identical wavy line. A difference is visible in the arrangement of the fish, who all swim in the same direction on the Bakar vessel. Unfortunately, this vessel is somewhat more poorly preserved and restored, hence individual details are unclear. A similar motif is also known on a deep vessel from the collection in Corning.⁶³

Naturally it is possible in this small group of products to note details in the quality of workmanship that mean that they were created in the same workshop, although they were not manufactured by one and the same master glass-worker. The motifs that appear on the vessels of this group from well dated contexts (end of the 2nd and beginning of the 3rd centuries) are related to decorations on Egyptian faience pottery, dated to the first two centuries AD.⁶⁴ Of the 19 known products belonging to this group, 12 are from Egypt,⁶⁵ with one each from Croatia and Slovenia.⁶⁶ Given the homogeneity of the group in terms of the quality of the glass, the composition of the decoration, and the characteristics of the engraving technique, it can be concluded that these were the products of an Egyptian workshop that began production in the second half of the 2nd century and exported its products to Italy, the Adriatic coast, and also to the western parts of the Empire.⁶⁷

It can be concluded on the basis of comparisons with the vessel from the E. Wolf collection that the find from Bakar had an identical figural motif and was manufactured in Egypt, probably in the same workshop.⁶⁸ The vessel is dated to the late 2nd century.

⁶⁰ Stern 2001, 136.

⁶¹ Id. 136.

⁶² Stern 2001, 156–158, no. 56.

⁶³ Whitehouse 1997, no. 401; Nenna 2003, 362, fig. 7.

⁶⁴ Nenna 2003, 362.

⁶⁵ Nenna 2007, 142.

⁶⁶ Lazar, Tomanič Jevremov 2000; Lazar 2007, 67.

⁶⁷ Nenna 2003, 362; 2007, 141.

⁶⁸ Stern 2001, 156.

⁶⁰ Stern 2001, 136.

⁶¹ Id. 136.

⁶² Stern 2001, 156–158, no. 56.

⁶³ Whitehouse 1997, no. 401; Nenna 2003, 362, fig. 7.

⁶⁴ Nenna 2003, 362.

⁶⁵ Nenna 2007, 142.

⁶⁶ Lazar, Tomanič Jevremov 2000; Lazar 2007, 67.

⁶⁷ Nenna 2003, 362; 2007, 141.

⁶⁸ Stern 2001, 156.

Čaše

Skupina čaša je prema broju prilično skromno zastupljena. Proizvodi koji su u rimsko doba upotrebljavani za piće, u rijetkim primjerima i za pohranu (primjerice malene čaše s udubljenjima i otiskom novca na dnu za kozmetičke pripravke i slično), kao grobni prilog su rjeđi negoli zdjelice. Analiza nekih groblja i grobnih priloga pokazuje da se u grobovima čaše često pojavljuju zajedno s bocama, vrčevima te keramičnim predmetima jednakih oblika.

Tri čaše pripadaju (t. 6: 1–3) skupini čaša s naboranim stijenkama ili udubljenjima (Is 32),⁶⁹ koje su se u rimsko doba pojavile u većem broju varijacija (sl. 7). Udubljenja, odnosno nabori na površini koje je oblikovao staklar dok je staklo još bilo toplo, okomiti su i najčešće ih je četiri. Poznajemo pak i proizvode na kojima je površina gušće naborana. Uglavnom su izrađeni od modrozelenkastog i bezbojnog stakla. Najranije čaše s naboranim stijenkama imaju cilindrično ili blago prema van nagnuto tijelo, rub je ravno odrezan ili zataljen, dno je ravno i u sredini udubljeno ili oblikovano u prstenastu nogu. Takvi oblici čaša pojavili su se sredinom 1. stoljeća te nadalje i česti su bili u flavijskom razdoblju, a javljali su se i u 2. stoljeću;⁷⁰ pokatkad ih nalazimo još u kontekstima 3. stoljeća (npr. Trier, Köln).

Čaše s udubljenjima oblika Is 32 (sl. 7 – lijevo) česti su nalazi u sjevernim provincijama (Trier, Vindonissa, Köln), u sjevernoj i središnjoj Italiji (Ticino, Alessandria, Rovigo, Herculanum, Settefinestre), te na sredozemnom području (Karanis, Tripoli, Cipar).⁷¹ Izrađivali su ih u različitim središtima, od Cipra do Kampanije.⁷² Sa slovenskih nalazišta poznajemo primjere u Ajdovščini, Cerknici, Logatcu, Drnovem, Šempetru i Starom trgu pri Slovenj Gradcu. Nalazi su datirani u drugu pol. 1. st. i u 2. st.⁷³ Iz emonskih grobova spomenimo usporedbe u grobovima 301,⁷⁴ 159 i 332.⁷⁵ Među nalazištima u Hrvatskoj spomenimo Pulu, Nezakcij, Burnum,⁷⁶ Argyruntum⁷⁷ i Zadar.⁷⁸

Čaša s udubljenjima na izvučenoj prstenastoj nozi (Is 35; t. 6: 3), prilično kvadrataste forme, pripada oblicima koji su pokatkad češći negoli potonja opisana skupina. U sjevernoj Italiji su vrlo rašireni u više inačica. Vjerojatno je u tom razdoblju na tom prostoru postojala radionica takvih čaša,⁷⁹ a vremenski raspon tih proizvoda seže od flavijskog vremena do 3. stoljeća.

Cilindrična čaša, koja se sužava prema rubu na stijenki ima nataljenu nit i stoji na niskoj nataljenoj prstenastoj nozi. S obzirom na usporedbe, proizvod je staklarskih radionica istočnog Sredozemlja, vjerojatno ciparskih (sl. 7 – desno). Analogije nisu česte, spomenimo nalaze iz Zadra koje čuvaju muzeji u Muranu⁸⁰ i Akvileji.⁸¹ Datirane su u drugu pol. 1. i u 2. st. Poradi oblika možda ih je moguće uspoređivati kao mlađu varijantu bikoničnih čaša nazvanih »a sacco«, ciparske proizvodnje, koje su služile i za pohranu.

⁶⁹ Lazar 2003, oblik 3.5.1.

⁷⁰ Cool, Price 1995, 70.

⁷¹ Biaggio Simona 1991, 102.

⁷² Scattozza Höricht 1986, 40.

⁷³ Lazar 2003, 100–101.

⁷⁴ Petru 1972, t. 27: 25.

⁷⁵ Plesničar Gec 1972, t. 44: 6; 86: 10.

⁷⁶ Trasparenze 1998, 126, no. 65–69.

⁷⁷ Fadić 1997, br. 94.

⁷⁸ Gluščević 1995, 221.

⁷⁹ Biaggio Simona 1991, 112.

⁸⁰ Ravagnan 1994, 187, no. 365, 366.

⁸¹ Calvi, 1968, 68, tav.: C: 9.

Beakers and goblets

Beakers are fairly modestly represented in terms of number. These products that were used for beverages in the Roman period, and in rare examples also for storage (such as small indented beakers with an impression of a coin on the base used for cosmetic unguents and so forth), are less common as grave goods than bowls. The analysis of several cemeteries and grave goods has shown that beakers often appear in graves together with bottles, jugs, and pottery products of the same shape.

Three beakers (pl. 6: 1–3) belong in the group of beakers with indented walls (Is 32),⁶⁹ which appear in the Roman period in a great number of variants (fig. 7). The hollows or indentations on the surface, which were formed by the glass-worker while the glass was still hot, are vertical and most often there are only four of them, although examples are known where the walls have more indentations. They were mostly made from blue-green and colourless glass. The earliest indented beakers have cylindrical or slightly outwards leaning walls, the rim is cut-off or fire-rounded, the base is flat and concave in the center or formed into a ring base. Such forms of beakers appear from the middle of the 1st century onwards and are common primarily in the Flavian period, while they also appear in the 2nd century,⁷⁰ and sometimes can even be found in 3rd century contexts (e.g. Trier, Köln).

Indented beakers of form Is 32 (fig. 7 – left) are frequent finds in the northern provinces (Trier, Vindonissa, Köln), in northern and central Italy (Ticino, Alessandria, Rovigo, Herculanum, Settefinestre), and in the Mediterranean region (Karanis, Tripoli, Cyprus).⁷¹ They were made in various production centres, from Cyprus to Campagna.⁷² Examples are known from Slovenian sites at Ajdovščina, Cerknica, Logatec, Drnovo, Šempeter and Stari trg near Slovenj Gradec. These finds are dated to the second half of the 1st century and in the 2nd century.⁷³ Similar finds are known from the Emona graves 301,⁷⁴ 159, and 332.⁷⁵ Finds in Croatia come from the sites of Pula, Nesactium, Burnum,⁷⁶ Argyruntum,⁷⁷ and Zadar.⁷⁸

A beaker with indentations on a tubular base ring (pl. 6: 3; Is 35), of fairly square shape, belongs among forms that are sometimes even more common than the above described group. Several variants were very widespread in northern Italy and a production centre for such beakers probably existed there.⁷⁹ The chronological span of these products extends from the Flavian period to the 3rd century.

A cylindrical beaker (pl. 6: 4), which narrows towards the rim, has an applied trail on the walls, and stands on a low applied ring base, was probably from Cyprus, given comparisons to the products of the glass-working centres of the eastern Mediterranean (fig. 7 – right). Analogies are not common, but finds from Zadar can be noted from the museums in Murano⁸⁰ and Aquileia.⁸¹ They are dated to the second half of the 1st and to the 2nd century. Perhaps because of their form

⁶⁹ Lazar 2003, form 3.5.1.

⁷⁰ Cool, Price 1995, 70.

⁷¹ Biaggio Simona 1991, 102.

⁷² Scattozza Höricht 1986, 40.

⁷³ Lazar 2003, 100–101.

⁷⁴ Petru 1972, pl. 27: 25.

⁷⁵ Plesničar Gec 1972, pl. 44: 6; 86: 10.

⁷⁶ Trasparenze 1998, 126, nos. 65–69.

⁷⁷ Fadić 1997, no. 94.

⁷⁸ Gluščević 1995, 221.

⁷⁹ Biaggio Simona 1991, 112.

⁸⁰ Ravagnan 1994, 187, nos. 365, 366.

⁸¹ Calvi, 1968, 68, pl.: C: 9.



Sl. 7 Čaše | Fig. 7 Beakers (Inv. br. / Inv. no. 11317, 11337, 11023)

Zvonasta čaša (t. 6: 5) s horizontalnim urezima i ravnim dnom (oblika Is 29) bila je raširena posuda za piće 1. stoljeća i višekratno je prikazana na istodobnim freskama s motivima simpozija. Izrađene su od prirodno obojenog ili dekoloriranoga stakla, koje može biti i mutno mliječno bijelo. Stijenke tih finih i tanko puhanih posuda su obično konusne, cilindrične, ili ovoidne, odnosno zvonaste. Ukras pak tvore pojedini vodoravni urezi. Najraniji proizvodi potječu iz tiberijskog vremena, a njihova uporaba potrajala je cijelo 1. stoljeće.⁸² Čaše su izrađivane u Italiji i sjeverozapadnim provincijama imperija, gdje su također raširene (Magdalensberg, Nîmes, Ticino);⁸³ pojedine primjere poznajemo i na istoku. Biaggio Simona utvrđuje da su najstariji proizvodi ovoidnog oblika, a kasnije su prevladavale konusne i više forme.⁸⁴ Nekoliko takvih čaša otkriveno je u Zatonu pokraj Zadra,⁸⁵ iz Slovenije spominjemo usporedbe iz Ribnice na Dolenjskem (neobjavljena građa) i Emona.⁸⁶

Čaša na nozi s visokim cilindričnim kaležom (t. 6: 6) ima posebno puhanu šuplju nogu i pripada široj skupini posuda koje su bile glatke, ukrašene urezima, nataljenim plastičnim ukrasom ili na njima nalazimo ugrebene natpise.⁸⁷ Te proizvode Harden pripisuje

they can be compared as a late variant of the biconical beakers called 'a sacco', of Cyprian production, which also served for storage.

A bell-shaped beaker (pl. 6: 5) with horizontal wheel-cut lines and a flat base (form Is 29) was a widespread type of drinking glass of the 1st century and was depicted several times on frescoes of the time with motifs of symposia. They were made of naturally coloured or decoloured glass, which can also be opaque milk white. The walls of these refined and thinly blown vessels are usually conical, cylindrical, or slightly ovoid or bell-shaped. The decoration consists of individual horizontal wheel-cut lines. The earliest products come from the Tiberian period, and their use continued throughout the entire 1st century.⁸² The beakers were manufactured in Italy and the northwestern provinces of the Empire, where they were also widespread (Magdalensberg, Nîmes, Ticino),⁸³ while individual examples are also known from the east. Biaggio Simona claimed that the earliest products had an ovoid form, while later conical and taller forms predominated.⁸⁴ Several such beakers were discovered at Zaton near Zadar,⁸⁵ while analogies from Slovenia are known from Ribnica na Dolenjskem (unpublished material) and Emona.⁸⁶

A footed goblet with a tall cylindrical chalice (pl. 6: 6) and a separately blown hollow foot belongs to a broad group of vessels that could be smooth, decorated with engravings or applied elements, or with

⁸² Stern 2001, 46.

⁸³ Czurda-Ruth 1979, 99, no. 753–561; Sternini 1991, 139, no. 556; Biaggio Simona 1991, 100, tav. 10.

⁸⁴ Biaggio Simona 1991, 101.

⁸⁵ Gluščević 1986, 260.

⁸⁶ Petru 1972, 163, t. 70: 932–9.

⁸⁷ Barkóczi 1981, 36; Lazar 2003, 114, oblici 3.8.4. in 3.8.5., sl. 34.

⁸² Stern 2001, 46.

⁸³ Czurda-Ruth 1979, 99, nos. 753–561; Sternini 1991, 139, no. 556; Biaggio Simona 1991, 100, pl. 10.

⁸⁴ Biaggio Simona 1991, 101.

⁸⁵ Gluščević 1986, 260.

⁸⁶ Petru 1972, 163, pl. 70: 932–9.

sirijskim radionicama i uvrštava ih u prvu pol. 3. st.;⁸⁸ neki raniji proizvodi pojavili su se već potkraj 2. stoljeća.⁸⁹ Najbrojnije usporedbe za čaše iz Bakra poznajemo u Panoniji i Porajnju, a također iz zbirke u Corningu.⁹⁰

Barkóczy ih je sakupio i razvrstao u četiri skupine prema obliku i sedam skupina prema ukrasu.⁹¹ S obzirom na jednostavan linearni ukras, čašu iz Bakra uspoređujemo sa skupinom proizvoda s brušenim ukrasom skupine 'g', kako ih razvrstava Barkóczy.⁹² U toj su skupini doduše poznatiji proizvodi s različitim natpisima, najčešće na grčkome. Slova su obično izrađena u više linija, motiv ukrasa je razdijeljen u više polja koja su ispunjena geometrijskim ili biljnim ukrasima. Ukras je izrađen plitkim ili dubokim urezom pomoću tokarskog stroja. Primjere poznajemo na području Crnog mora, s nalazišta Tanais i Pantikapaion, gdje je figuralni ukras naslikan na površinu čaše.⁹³ U Kölnu je, primjerice, očuvana čaša s figuralnim ukrasom, koji prikazuje Prometeja.⁹⁴

Prvotno su te čaše, ponajprije poradi grčkih natpisa, pripisivali aleksandrijskim radionicama.⁹⁵ Kasnije je Fremersdorf utvrdio da više od trećine očuvanih posuda s figuralnim ukrasom potječe iz kölnskog područja, ali i ostala nalazišta su u vezi sa izvozom iz Kölna.⁹⁶ Prema tome utvrdio je kako je većina proizvoda nastala u kölnskim radionicama.⁹⁷ Kölnske radionice su djelovale od kraja 2. stoljeća i u 3. stoljeću, a njihovi proizvodi povezani su s dotokom stanovnika sa istoka potkraj 2. stoljeća, među kojima su bili staklarski majstori.⁹⁸ Barkóczy je poradi brojnih ulomaka tih čaša i ukrasnih motiva povezanih s panonskim nalazištima pobornik lokalne proizvodnje u Intercisi, gdje je u 3. stoljeću djelovala staklarska radionica.⁹⁹

Djelomice očuvana čaša iz Bakra ima zbog jednostavnog ukrasa vodoravnih ureza odgovarajuću istodobnu usporedbu iz zbirke u Corningu.¹⁰⁰ Slične, ali nešto više čaše otkrivene su na jednom od rimskih groblja u Sudanu (grob WT 8-Sedeinga).¹⁰¹ Datirane su u drugu pol. 3. st.¹⁰²

Visoka zvonolika čaša (t. 6: 7), koja se na prijelazu u dno širi u nabor i preko zaokruženog dna završava na visokoj, posebno puhanjoj šupljoj nozi također nosi jednostavan ukras. Stijenka je ukrašena s tri pojasa gustih i plitkih ureza, a ispod odebljanog ruba nataljena je staklena nit. Izrađena je od finog, dekoloriranog stakla. Oblik bi odgovarao formi Is 36b, no nažalost odgovarajuće usporedbe su rijetke. Po obliku srodan, ali prilično robusnije izrađen, proizvod je poznat iz zbirke u Corningu,¹⁰³ Apta i Arlesa u Francuskoj.¹⁰⁴ Čaše te vrste česte su na nalazištima Velike Britanije i predstavljaju najrašireniju pivsku posudu te provincije

incised inscriptions.⁸⁷ These products were attributed by Harden to Syrian workshops and dated to the first half of the 3rd century,⁸⁸ while some earlier examples appeared already at the end of the 2nd century.⁸⁹ The most numerous analogies for the goblet from Bakar are known from Pannonia and the Rhine valley, as well as from the Corning collection.⁹⁰

Barkóczy gathered and classified them into four groups according to form and seven groups according to decoration.⁹¹ In terms of the simple linear decoration, the goblet from Bakar can be compared with the group of products with wheel-cut decoration of Barkóczy's group 'g'.⁹² This group is better known for products with various inscriptions, most often in Greek. The letters were usually written in several lines, and the decorative motif was separated into several fields filled with geometric or floral decorations. The decoration was made with wheel-cut shallow or deep lines. Examples are known from the Black Sea region, from the sites of Tanais and Pantikapaion, where the figural decoration was painted onto the surface of the goblet.⁹³ A goblet with figural decoration is preserved in Köln, depicting Prometheus.⁹⁴

Originally these goblets were attributed to Alexandrian workshops, primarily because of the Greek inscriptions.⁹⁵ Later Fremersdorf established that more than a third of the preserved vessels with figural decoration came from the Köln region, and that the other finds were also tied to the Köln export area.⁹⁶ From these conclusions he established that the majority of products had been created in the Köln workshops.⁹⁷ The Köln production centres were active from the end of the 2nd century and in the 3rd century, and their products are connected to the arrival of inhabitants from the east at the end of the 2nd century, including expert glass-workers.⁹⁸ The numerous fragments of these goblets, tied by decorative motifs, at Pannonian sites led Barkóczy to suggest local production at Intercissa, where a glass workshop was active in the 3rd century.⁹⁹

The only partly preserved goblet from Bakar has the closest analogies because of the simple decoration of horizontal incised lines to an example from the collection in Corning.¹⁰⁰ Similar, but somewhat taller goblets were discovered at one of the Roman cemeteries in the Sudan (grave WT 8-Sedeinga).¹⁰¹ They are dated to the second half of the 3rd century.¹⁰²

A tall bell-shaped goblet (pl. 6: 7), which at the transition to the base broadens into a biconical section, and whose rounded base ends in a tall, separately blown hollow foot, was decorated on the walls with three bands of dense and shallow incised lines, with an applied glass trail below the thickened rim. It was made of refined decoloured glass. The form would correspond to Is 36b, but unfortunately only

⁸⁸ Barkóczy 1981, 57.

⁸⁹ Barag 1967, 59.

⁹⁰ Whitehouse 1997, 251, no. 128, 429.

⁹¹ Barkóczy 1981, 36.

⁹² Barkóczy 1981, 36.

⁹³ Sorokina 1979, Abb. 2.

⁹⁴ Fremersdorf 1951, Taf. 10.

⁹⁵ Morin-Jean 1913, 240; Harden 1936, 101.

⁹⁶ Fremersdorf 1951, 22.

⁹⁷ Fremersdorf 1951, 23.

⁹⁸ Fremersdorf 1959, 15.

⁹⁹ Barkóczy 1981, 56.

¹⁰⁰ Whitehouse 1997, 251, 429.

¹⁰¹ Leclant 1973, 55–56, fig. 2–4.

¹⁰² Leclant 1973, 68.

¹⁰³ Whitehouse 1997, 228, no. 387.

¹⁰⁴ Foy, Nenna 2003, 286, no. 227, 228.

⁸⁷ Barkóczy 1981, 36; Lazar 2003, 114, forms 3.8.4 and 3.8.5, fig. 34.

⁸⁸ Barkóczy 1981, 57.

⁸⁹ Barag 1967, 59.

⁹⁰ Whitehouse 1997, 251, nos. 128, 429.

⁹¹ Barkóczy 1981, 36.

⁹² Barkóczy 1981, 36.

⁹³ Sorokina 1979, fig. 2.

⁹⁴ Fremersdorf 1951, pl. 10.

⁹⁵ Morin-Jean 1913, 240; Harden 1936, 101.

⁹⁶ Fremersdorf 1951, 22.

⁹⁷ Fremersdorf 1951, 23.

⁹⁸ Fremersdorf 1959, 15.

⁹⁹ Barkóczy 1981, 56.

¹⁰⁰ Whitehouse 1997, 251, 429.

¹⁰¹ Leclant 1973, 55–56, fig. 2–4.

¹⁰² Leclant 1973, 68.

u prvoj pol. i sredinom 2. st.¹⁰⁵ Poznat je velik broj inačica, a ugrubo razlikujemo dvije skupine: ranija koja ima prstenastu nisku nogu, i druga skupina s visokom, posebno puhanom nogom. Tijelo je konusno, cilindrično ili konveksno. Nalazi pokazuju da je njihova uporaba najraširenija sredinom i u drugoj pol. 2. st., a tijekom 3. stoljeća njihov se broj vidljivo smanjio.¹⁰⁶

Vrčevi

Kao skupinu vrčeva oprijedijelili smo posude s ručkom (ili dvije), koje imaju stajaću površinu zamjetno užu od najveće širine stijenke; posuda je kuglastog, kruškastog ili bikonusnog oblika. U pravilu imaju jednu ručku. Prvenstveno su te posude bile namijenjene uporabi na stolu – pri posluživanju hrane i vina, vode i vjerojatno još kakve tekućine. Oblik je već ranije, odnosno od početka uporabe slobodno puhanih staklenih posuda zastupljen i kao grobni prilog u bogatijim grobovima.

Vrčevi s duljim uskim vratom pripadaju najranijim stolnim proizvodima luksuznog staklenog posuđa. Njihovo tijelo je kruškasto, kuglasto ili malo stlačenije bučasto. Vrat završava razgrnutim ili prema natrag svinutim i spljoštenim rubom. Ručke tih posuda su precizno izrađene, rebraste i pričvršćene na rame posude te srednji ili gornji dio vrata. Njihova značajka je i oštar kut u pregibu ručke. Dno je ravno ili oblikovano u nogu te na sredini udubljeno. Proizvodi su puhani od obojenog ili od marmoriziranog stakla (ukras obojenih mrlja na stijenci). Svi primjeri iz Bakra izrađeni su od modrozelenkastog stakla (sl. 8).

Vrč bez oblikovane noge, s ovalnim stijenka, vodoravnim urezima i blago stisnutim prijelazom vrata u stijenku pripada varijanti oblika Is 14 (t. 7: 1). Značajka mu je uvlačka na kraju vrata, a nije češći ni plići vodoravni ukras brušenih linija. Po veličini je to najveća posuda među očuvanim vrčevima iz Bakra i mogla je služiti za serviranje vina ili vode na stolu. To su rani oblici vrčeva koje poznajemo još od prve polovine 1. stoljeća. Varijanta sa stisnutim prijelazom vrata i malo više postavljenom ručkom je mlađa i pretežno se javljala od sredine stoljeća nadalje.¹⁰⁷ Pretpostavlja se da je riječ o proizvodima sjevernotalijanskih radionica, a najviše primjera nalazimo upravo u Padovi,¹⁰⁸ Akvileji¹⁰⁹ i Trevisu.¹¹⁰ Među primjerima iz Hrvatske spomenimo vrč iz zbirke u zadarskome muzeju.¹¹¹ Datirani su u 1. stoljeće,¹¹² a pokad tad ih još nalazimo u kontekstima 2. stoljeća.

Drugi oblik vrča (t. 7: 2), opredijeljen kao forma Is 55a, prvenstveno srodan bikonusnim oblicima Is 14 i 13 posebno je raširen na području sjeverne Italije i Ticina,¹¹³ a malo manje na području Akvileje. Stoga je već Calvi izrazila mišljenje o mogućoj

rare analogies are known. Examples similar in shape, but more robustly made are known from the Corning collection,¹⁰³ and Apt and Arles in France.¹⁰⁴ Goblets of this type are very common at sites in Great Britain as they represent the most widespread drinking vessel of that province in the first half and middle of the 2nd century.¹⁰⁵ An exceptionally large number of variants are known, and two groups can be roughly distinguished: the earlier has a low ringed foot, and the other group a tall specially blown foot. The body is conical, cylindrical, or somewhat convex. The finds indicate that their use was most widespread in the middle and second half of the 2nd century, while through the 3rd century their number visibly declined.¹⁰⁶

Jugs

The group of jugs has been defined as vessels with a handle (or two) and a standing surface considerably smaller than the broadest diameter of the walls, globular, pear-shaped or biconical in form. As a rule they have one handle. These vessels were primarily intended for use at the table – for serving wine, water, and probably other beverages. The form was present quite early, from the beginning of the use of free-blown glass vessels, as a grave good in wealthy graves.

Jugs with a long narrow neck belong among the earliest luxurious glass tableware products. Their bodies could be pear-shaped, globular, or compressed sideways. The neck ends in a folded rim with the edge bent and flattened. The handles of these vessels were precisely made, ribbed, and attached to the shoulder of the vessel and the central or upper part of the neck. One characteristic feature is the sharp angle where the handle is bent. The base is flat or formed into an open ring foot, and is concave in the centre. The jugs were blown from coloured or marbled glass (a decoration of coloured spots on the walls). All the examples from Bakar were made of blue-green glass (fig. 8).

A jug with a simple base and with oval walls, horizontal incised lines, and a slight constriction at the transition from the neck to the walls, belongs to a variant of the form Is 14 (pl. 7: 1). A characteristic feature is the constriction at the end of the neck, while the decoration of shallow wheel-cut lines is not very common. In terms of size, this is the largest vessel among the preserved jugs from Bakar, and it could have been used for serving wine or water. These are early types of jugs known from as early as the first half of the 1st century. The variant with the constricted transition to the neck and a somewhat higher placed handle is later and appeared primarily from the middle of the century and later.¹⁰⁷ It is considered that these were produced in northern Italian workshops, and the greatest number of analogies can in fact be found in Padova,¹⁰⁸ Aquileia,¹⁰⁹ and Treviso.¹¹⁰ Other examples from Croatia include a jug from the collection of the Archaeological Museum in Zadar.¹¹¹ Such jugs are dated to the 1st century,¹¹² and sometimes they can still be found in 2nd century contexts.

¹⁰⁵ Cool, Price 1995, 79.

¹⁰⁶ Cool, Price 1995, 79–80.

¹⁰⁷ Isings 1957, 31.

¹⁰⁸ Zampieri 1998, 152, no. 250.

¹⁰⁹ Mandruzzato, Marcante 2005, 83, 152.

¹¹⁰ Casagrande, Ceselin 2003, 193–194, no. 304, 305.

¹¹¹ Trasparenze 1998, 162, no. 131.

¹¹² Mandruzzato, Marcante 2005, 83.

¹¹³ Biaggio Simona 1991, 190.

¹⁰³ Whitehouse 1997, 228, no. 387.

¹⁰⁴ Foy, Nenna 2003, 286, nos. 227, 228.

¹⁰⁵ Cool, Price 1995, 79.

¹⁰⁶ Cool, Price 1995, 79–80.

¹⁰⁷ Isings 1957, 31.

¹⁰⁸ Zampieri 1998, 152, no. 250.

¹⁰⁹ Mandruzzato, Marcante 2005, 83, 152.

¹¹⁰ Casagrande, Ceselin 2003, 193–194, nos. 304, 305.

¹¹¹ Trasparenze 1998, 162, no. 131.

¹¹² Mandruzzato, Marcante 2005, 83.



Sl. 8 Vrčevi | Fig. 8 Jugs (Inv. br. / Inv. no. 11067, 11065, 11006)

proizvodnji na srednje padanskom dijelu Italije,¹¹⁴ Biaggio Simona pak spominje proizvodnju u ticinskom i piemontskom području.¹¹⁵ Usporedbe poznajemo u emonskim grobovima¹¹⁶ te u Hrvatskoj u Zadru.¹¹⁷

Vrčevi s konusno oblikovanim tijelom u grobnim su se cjelinama pojavili sredinom 1. stoljeća, a najveću rasprostranjenost zadobili su u klaudivsko-neronskom i trajanskom razdoblju, što znači da je njihova proizvodnja obuhvatila sredinu i treću četvrtinu 1. stoljeća.¹¹⁸

Vrčevi s kuglastim ili blago konusnim stijenkama i dnom oblikovanim u nogu (Is 52a) su jednako tako značajan proizvod radionica 1. stoljeća (t. 7: 3). Njihova veličina varira od malih do gotovo 30 cm visokih posuda. S obzirom na rasprostranjenost i učestalost nalaza u talijanskom prostoru, Biaggio Simona pretpostavlja da je riječ o proizvodima koji su vjerojatno nastali u radionicama središnje, sjeverne ili zapadne Italije.¹¹⁹ Izvan Italije nalazimo ih među inima još u Vindonisi,¹²⁰ Trieru,¹²¹

Another form of jug (pl. 7: 2), classified as form Is 55a, is fairly similar to the biconical forms Is 14 and 13, and is particularly widespread in the region of northern Italy and Ticino,¹¹³ and somewhat less in the region of Aquileia. Hence Calvi suggested a possible production in the central Po valley region of Italy,¹¹⁴ while Biaggio Simona also mentioned as possible production in the Ticino and Piedmont regions.¹¹⁵ Analogies are known from graves at Emona in Slovenia,¹¹⁶ and in Croatia from Zadar.¹¹⁷

Jugs with conical bodies appear in grave units sometime in the middle of the 1st century, and the greatest distribution is noted between the reigns of Claudius, Nero and Trajan, meaning that their production probably took place between the middle and third quarter of the 1st century.¹¹⁸

Jugs with globular or slightly conical walls and an open ring base (Is 52a) are an equally characteristic product of 1st century workshops (pl. 7: 3). Their dimensions vary from somewhat small to almost 30 cm high vessels. Considering the distribution and frequency of finds in the Italian region, Biaggio Simona hypothesized that these were products probably manufactured in the workshops of central,

¹¹⁴ Calvi 1968, 212.

¹¹⁵ Biaggio Simona 1991, 190.

¹¹⁶ Plesničar Gec 1972, 157, gr. 35, 141, 168, 194, 320.

¹¹⁷ Trasparenze 1998, no. 131, 134.

¹¹⁸ Biaggio Simona 1991, 191.

¹¹⁹ Biaggio Simona 1991, 196.

¹²⁰ Berger, 1960, 42, no. 89.

¹²¹ Goethert Polaschek 1977, 190–191.

¹¹³ Biaggio Simona 1991, 190.

¹¹⁴ Calvi 1968, 212.

¹¹⁵ Biaggio Simona 1991, 190.

¹¹⁶ Plesničar Gec 1972, 157, gr. 35, 141, 168, 194, 320.

¹¹⁷ Trasparenze 1998, nos. 131, 134.

¹¹⁸ Biaggio Simona 1991, 191.

Emoni¹²² i na Cipru.¹²³ Oblik je nastao još u tiberijskom razdoblju. Rasprostranjen je bio od druge četvrtine do kraja 1. stoljeća.¹²⁴

Posve drukčiju, robusniju formu predstavlja vrč s jednom ručkom i širokim, kratkim vratom (t. 7: 4). Vrat je kratak i prelazi u prema van nagnut rub koji je jednostavno svinut prema unutra; na nj je nataljena trakasta ručka koji se na vrhu širi u oslonac za palac. Vrču nalazimo posve malo odgovarajućih usporedbi, srodne primjere poznajemo iz muzeja u Corningu u SAD-u, a datiran je u 1. i 2. stoljeće.¹²⁵ Najbliže analogije lako se mogu naći na hrvatskim nalazištima u Zadru i Argyruntumu.¹²⁶ Možda bi u tom primjeru mogli vidjeti oblik koji je nastao u lokalnim radionicama toga područja. Vrčevi su datirani u drugu pol. 1. st. i u 2. st.

Dva vrča – jedan je očuvan u cijelosti, a drugi djelomice (t. 7: 5, 6), – imaju obod oblikovan u izljev. Možemo ga opredijeliti kao oblik Is 56b. Izljev oba vrča nije djetelinasto oblikovan, kao primjerice kod oblika Is 56a, ali je produžen u kljunastiju formu. Trakasta ručka koja je pričvršćena na rub posude i u tom se primjeru širi u oslonac za palac. U cijelosti očuvan vrč kvalitetne izrade i vrlo tanko puhanog stakla ima usporedbe među građom kantona Ticino, u Bresciji,¹²⁷ Akvileji¹²⁸ i Emoni,¹²⁹ iako su potonji prilično većih dimenzija (20 cm). Među nalazima iz Herkulanuma i Pompeja nalazimo slične vrčeve koji po kvaliteti nadilaze nalaze iz sjeverne Italije.¹³⁰ Nažalost, rijetki su nalazi iz dobro datiranih konteksta, a taj oblik posude opredjeljujemo u drugu pol. 1. st. i prvu pol. 2. st.¹³¹

northern, and western Italy.¹¹⁹ Outside of Italy, they can be found among other places at Vindonissa,¹²⁰ Trier,¹²¹ Emona,¹²² and on Cyprus.¹²³ The form evolved as early as the Tiberian period, and was widespread from the second quarter to the end of the 1st century.¹²⁴

A completely different, more robust form is represented by a jug with one handle and a wide, short neck (Pl. 7: 4). The neck is short and merges into an everted rim that is simply turned inwards, with a ribbon handle attached to it that has a thumb-rest on the top. Quite few entirely corresponding analogies to this jug can be found, while related examples are in the museum in Corning, dated to the 1st and 2nd centuries.¹²⁵ The closest analogies can be sought at Croatian sites, and particularly at Zadar and Argyruntum.¹²⁶ Perhaps in this case it would be possible to perceive a form that was created in the local workshops of this region. Such jugs are dated to the second half of the 1st century and the 2nd century.

Two jugs, one of them entirely preserved, and the other partially (pl. 7: 5, 6), have rims formed into a spout, and can be classified as form Is 56b. The spouts of both jugs are not trefoil shaped, like form Is 56a, for example, but rather are elongated into a beaked form. The ribbon handle attached to the edge of the rim in this case also spreads into a thumb-plate. The completely preserved jug of high quality workmanship and very thinly blown glass has analogies among the material from the canton of Ticino, from Brescia,¹²⁷ Aquileia,¹²⁸ and Emona,¹²⁹ although the latter have fairly large dimensions (20 cm). Similar jugs that surpass the finds from northern Italy in quality can be found among the finds from Herculaneum and Pompeii.¹³⁰ Unfortunately, finds are rare from well dated contexts, and at present this form is dated to the second half of the 1st and second half of the 2nd century.¹³¹

¹²² Plesničar Gec 1972, 205, gr. 365.

¹²³ Vessberg 1952, 130 Bl, pl. VI, 11, 12.

¹²⁴ Biaggio Simona 1991, 197; Stern 2001, 49.

¹²⁵ Whitehouse 1997, 359, 189, sl. 331.

¹²⁶ trasparenze 1998, 181, no. 169, 170.

¹²⁷ Biaggio Simona 1991, 206.

¹²⁸ Calvi 1968, 62, no. 152.

¹²⁹ Plesničar Gec 1972, 119, gr. 326; Petru 1972, 164, gr. 23.

¹³⁰ Scattozza Hörich 1986, 49, no. 29.

¹³¹ Biaggio Simona 1991, 209.

¹¹⁹ Biaggio Simona 1991, 196.

¹²⁰ Berger, 1960, 42, no. 89.

¹²¹ Goethert Polaschek 1977, 190-191.

¹²² Plesničar Gec 1972, 205, gr. 365.

¹²³ Vessberg 1952, 130 Bl, pl. VI, 11, 12.

¹²⁴ Biaggio Simona 1991, 197; Stern 2001, 49.

¹²⁵ Whitehouse 1997, 359, 189, fig. 331.

¹²⁶ trasparenze 1998, 181, nos. 169, 170.

¹²⁷ Biaggio Simona 1991, 206.

¹²⁸ Calvi 1968, 62, no. 152.

¹²⁹ Plesničar Gec 1972, 119, gr. 326; Petru 1972, 164, gr. 23.

¹³⁰ Scattozza Hörich 1986, 49, no. 29.

¹³¹ Biaggio Simona 1991, 209.

Posuđe za pohranu

Boce

Kako se Rimsko Carstvo munjevito proširilo po cijeloj Europi, tijekom 1. stoljeća s njim se proširio i staklarski obrt i njegov razvojni dosezi. Iz sjeverne i sjeveroistočne Italije staklarske su se radionice proširile i nadalje razvijale u svim novim provincijama Carstva. Važni i inovativni pomaci u samoj staklarskoj industriji zbivali su se upravo u 1. stoljeću, kada je za puhanje stakla uvedena metalna staklarska cijev, a zajedno s njom još neki drugi pomoćni alati, primjerice metalna motka ili hvataljka te puhanje u kalup.¹³²

Upravo takvi napretci omogućili su razvoj u smislu nove funkcije i uporabe staklenih proizvoda. Pojavile su se velike staklene posude za pohranu i transport, njihovu izradu je omogućila upravo uporaba metalne staklarske cijevi. Masovna proizvodnja tih uporabnih proizvoda još je više pojednostavnila uporaba glatkih, najvjerojatnije drvenih kalupa u koje su puhali stijenke boca i tako omogućili brzu i opsežnu proizvodnju posuđa široke uporabe. Povećanoj potražnji i popularnosti tih proizvoda pripomogao je njihov oblik prikladan za transport u drvenim sanducima kao i osobine stakla. Posude nisu preuzele miris sadržaja koji su pohranjivale; stoga ih je bilo moguće višekratno upotrijebiti za različite sadržaje. Različiti otisci koje prepoznajemo na dnu tih proizvoda, u obliku natpisa ili kratica kao i različitih figuralnih i geometrijskih motiva mogu odražavati opseg i trgovački potencijal pojedinih radionica kao i sadržaj ili proizvođača sadržaja koje su u staklenim posudama transportirali.¹³³

Primjena zahtjevne tehnike puhanja u ukrašene kalupe, koja je bila u uporabi za izradu malih luksuznih staklenih proizvoda i za masovnu proizvodnju transportnog posuđa se, prema mišljenju E. M. Stern, lako mogla razviti u sjevernoitaljskim radionicama, možda u Akvileji, jer su staklarski majstori izvrsno ovladali svojim obrtom u svim njegovim detaljima.¹³⁴

Devet boca kvadratnog i pravokutnog oblika, koje su bile očuvane u bakarskim grobovima, govore o popularnosti i proširenosti tog oblika kao posuđa za pohranu i transport (sl. 9). Četverokutne boce bile su puhane u kalupe ili slobodno puhane i dorađene tj. dooblikovane. Nakon puhanja su ih još vruće spljoštili na mramornoj ili željeznoj ploči ispred peći.¹³⁵ Najčešće su boce s

¹³² Stern 2005, 2007; Lazar 2005c.

¹³³ Lazar 2005a; 2006e.

¹³⁴ Stern 2001, 41.

¹³⁵ Seitter 1991, 527, Abb. 1, 2.

Storage vessels

Bottles

Just as the Roman Empire spread with lightning speed throughout all of Europe in the 1st century, so too did glass working and its developmental achievements. The glass production centres spread from northern and northeastern Italy, and developed further in all the new provinces of the empire. Important and innovative improvements in the glass industry in fact occurred in the 1st century, when the metallic glass blowing pipe was introduced, together with other implements, such as the metal rod or pontil, as well as the technique of blowing into a mould.¹³²

Such advances enabled development in the sense of new functions and uses for glass products. Large glass vessels for storage and transport appeared, and their manufacture was in fact enabled by the use of metal glass-blowing pipes. The mass production of such objects of everyday use was further simplified by the utilization of smooth, probably wooden moulds into which the walls of bottles were blown, thus enabling the rapid and extensive production of vessels of widespread use. The increased demand for and popularity of such products was aided by their form, suitable for transport in wooden cases, as well as by the very characteristics of glass. The vessels did not pick up the scent of the contents they contained, and hence they could be reused several times for different materials. The various stamps known from the bases of these products, in the form of inscriptions or abbreviations or various figural and geometric motifs could reflect the span and trade potential of individual production centres, as well as the contents or the producer of the contents transported in the glass vessels.¹³³

The transferal of the demanding technique of blowing glass into a decorative mould, which had previously been used for the manufacture of small luxurious glass products, to the mass production of blown vessels for transport, could well have developed, according to Stern, in the northern Italian workshops, perhaps in Aquileia, where the master glass-workers had perfected knowledge of their craft to the smallest details.¹³⁴

The nine bottles of square and rectangular form that were preserved from the Bakar graves indicate how popular and widespread this form was as a storage and transport vessel (fig. 9). The square bottles were blown into a mould or free blown and further processed. After they were blown, while still hot, they were flattened on a marble or

¹³² Stern 2005, 2007; Lazar 2005c.

¹³³ Lazar 2005a; 2006e.

¹³⁴ Stern 2001, 41.

kvadratnim stijenkama, rjeđe su pravokutne i prizmatične, a trokutaste su rijetke.¹³⁶

Ručke na bocama pričvršćene su tik pod obodom i na prijelazu vrata u tijelo boce, odnosno na ramenu. Uobičajena je jedna, odnosno dvije ručke kod nekih pravokutnih i poligonalnih boca. Najčešće su široke, gusto rebraste (izrađene posebnim oruđem – češljem), neke su također glatke (trakaste), profilirane, ponekad sa dva ili tri rebra.¹³⁷ Najranije boce znane su sa Magdalensberga.¹³⁸ Široku uporabu zadobile su od druge pol. 1. st. U uporabi su bile tijekom duljega razdoblja, ponegdje još u 4. stoljeću.¹³⁹

Posebna značajka četverokutnih boca je i na dnu utisnut ornament, odnosno pečat. Objasnjavamo ih kao oznake radionica ili proizvođača, poznajemo ih i na četverokutnim loncima.¹⁴⁰ Svi ti otisci znače svojevrsni zaštitni znak. Njihovo proučavanje odgovara na pitanja o distribuciji i trgovačkim putevima pojedinih proizvoda.¹⁴¹

Među arheološkim nalazima očuvalo se i nekoliko kalupa pomoću kojih su ukrašavana dna boca. Najčešće su bili izrađeni od kamena koji je očito izvanredno postojan, te također od keramike.¹⁴² Među motivima najčešće su očuvani uzorci koncentričnih krugova; posebno zanimljiv primjerak iz Hrvatske je kalup iz Salone s prikazom gladijatora i imenom majstora *Miscenius Ampliatus*.¹⁴³

Najbrojniji otisci ili žigovi najrazličitijih tipova poznati su sa četvrtastih boca (sl. 10). Razlikujemo dvije veće skupine – uzorke s koncentričnim krugovima, geometrijskim i figuralnim motivima te slovima. Brojni i različiti otisci na dnu staklenih posuda s europskih nalazišta nedavno su prikupljeni u okviru projekta *Les marques sur verre*, koji je pokrenuo AFAV, a o tome su objavljene dvije publikacije koje su uredili M.-D. Nenna i D. Foy.¹⁴⁴

Skupina otisaka koja predstavlja plastične koncentrične krugove je najbrojnija. Najčešći otisci u toj skupini su sastavljeni od dva, tri, četiri ili pet krugova. Neki primjeri su kombinacija koncentričnih krugova s točkama i kombinacija krugova i rozeta, a ostali tipovi predstavljeni su s po jednim fragmentom. U Bakru su očuvane dvije boce sa četiri koncentrična kruga na dnu (t. 8: 1, 4).

Boce s koncentričnim krugovima na dnu zastupljene su u većem broju u grobovima u Ljubljani, na Ptuju i Drnovom, a samo su neki nalazi poznati iz naselja. To upućuje tek na stanje istraživanja i ne znači da taj materijal ne poznajemo i iz naselja. Do sada nije postojala mogućnost intenzivnijeg istraživanja staklenih nalaza iz naselja tijekom terenskih istraživanja ili čak publikacija. Prvi je pokušaj učinjen tijekom posljednjeg iskopavanja 2001–2003. godine u Ribnici. Ispitivanjem materijala s Ribnice (rimska putna postaja *Romula* na cesti *Aquileia-Emona-Siscia*) opažamo da su fragmenti dna boca relativno brojni među nalazima stakla u naselju;¹⁴⁵ otisci na njima uključuju plastične koncentrične krugove te neke druge oznake. Nasebinski nalazi s putne postaje u Ribnici na Dolenjskom bili su otkriveni u sloju s kraja 1. stoljeća i iz 2. i 3. stoljeća.¹⁴⁶

¹³⁶ Cool, Price 1995, 179.

¹³⁷ Rottloff 1999, 41.

¹³⁸ Czurda-Ruth 1979, 135.

¹³⁹ Isings 1957, 64–65.

¹⁴⁰ Stern 1997, 130; Lazar 2006b.

¹⁴¹ Lazar 2006e.

¹⁴² Amrein, Nenna 2006, 491–504.

¹⁴³ Rottloff 1999, 42, Abb. 2–5; Buljević 2005a, 193.

¹⁴⁴ Foy, Nenna 2006a.

¹⁴⁵ Lazar 2006b, SI 49–62; 65.

¹⁴⁶ Lazar 2006b, 245.

iron slab in front of the furnace.¹³⁵ Bottles with a square-sectioned body are most common, while rectangular or prismatic forms, and especially triangular forms, are more rare.¹³⁶

The handles on bottles were attached just below the rim and at the transition from the neck to the body of the bottle, at the shoulder. One handle is usual, while some rectangular and polygonal bottles have two. They are mostly broad and densely ribbed (or »reeded«, with a special combed tool), and some are smooth (band, ribbon handles), profiled, or have two or three ribs.¹³⁷ The earliest bottles are known from Magdalensberg,¹³⁸ while widespread utilization occurred from the second half of the 1st century onwards. They were in use throughout a long span of time, and can be traced in certain areas as late as the 4th century.¹³⁹

A special characteristic of square bottles is the ornament or rather stamp pressed into the base. They are explained as the marks of the workshop or producer, and they can also be found on square jars.¹⁴⁰ All of these impressions represent a kind of trademark, and their study can lead to insight about the distribution and trade routes of individual products.¹⁴¹

Some moulds used to decorate the base of bottles have been preserved among archaeological material. They were most often made of stone, which was evidently longest lasting, and also of pottery.¹⁴² The most commonly preserved motifs are patterns of concentric circles; a particularly interesting example is a mould from Salona with an image of a gladiator and the name of *Miscenius Ampliatus*.¹⁴³

The most numerous and diverse types of base marks are known from square bottles (fig. 10). Two large groups can be defined – designs with concentric circles, geometric and figural motifs and letters. The numerous base marks on glass vessels from European sites were recently collected in the framework of the project *Les marques sur verre*, initiated by the AFAV and published in two publications edited by M.-D. Nenna and D. Foy (2006).¹⁴⁴

The group of base marks with relief concentric circles is the most numerous. The commonest marks in this group consist of two, three, four or five circles. Individual examples are represented with only one but also with seven concentric circles. Some examples exhibit a combination of concentric circles with dots or a combination of circles and rosettes, while other types are represented by only one fragment. Two bottles with four concentric circles on the base have been preserved from Bakar (pl. 8: 1, 4).

Bottles with concentric circles on the bottom are often present in graves from Ljubljana, Ptuj, and Drnovo, while only few finds are known from settlements. This merely reflects the present state of research and does not mean such material cannot be found at settlements. So far no possibility has existed to study glass finds intensively from settlements during the course of excavation or even afterwards for publication. A first attempt was made for the most recent excavations in 2001–2003 at Ribnica. If we look at the material from Ribnica (the Roman road station *Romula* on the *Aquileia-*

¹³⁵ Seitter 1991, 527, fig. 1, 2.

¹³⁶ Cool, Price 1995, 179.

¹³⁷ Rottloff 1999, 41.

¹³⁸ Czurda-Ruth 1979, 135.

¹³⁹ Isings 1957, 64–65.

¹⁴⁰ Stern 1997, 130; Lazar 2006b.

¹⁴¹ Lazar 2006e.

¹⁴² Amrein, Nenna 2006, 491–504.

¹⁴³ Rottloff 1999, 42, fig. 2–5; Buljević 2005a, 193.

¹⁴⁴ Foy, Nenna 2006a.



Sl. 9 Cilindrična i kvadratne boce | Fig. 9 Cylindrical and square bottles (Inv. br. / Inv. no. 11002, 11004, 11005)



Sl. 10 Kvadratne boce | Fig. 10 Square bottles

Grobovi iz Emone (Ljubljana) datirani su od druge pol. 1. st. do početka 3. st.¹⁴⁷ Postoji primjer skeletnog ukopa sa staklenom bocom s kraja 3. i početka 4. stoljeća.¹⁴⁸ Nalazi iz Poetovione (Ptuj) i Neviodunuma (Drnovo) većinom su stari nalazi otkriveni u 19. i početkom 20. stoljeća i samo neki među njima mogu biti datirani prema poznatim grobnim priložima.¹⁴⁹ Iz Hrvatske spominjemo objavljene usporedbe iz Argyruntuma i Zadra.¹⁵⁰

Sljedeći otisci dna su točke u kombinaciji s rombom (t. 9: 1). Jednak se znak pojavljuje na dnu kvadratičnih boca iz groba 463 u Ptuj, ¹⁵¹ datiranih u drugu pol. 2. i početak 3. st.¹⁵² Nalazi iz Mađarske datirani su u drugu pol. 1. st.,¹⁵³ iz Aquileije na svršetak 1. i u 2. st.,¹⁵⁴ a trebamo spomenuti i udaljenu paralelu iz Cesareje u Alžiru.¹⁵⁵

Rozete kao otisci na dnu su uobičajene i predstavljene su s nekoliko tipova: šestolisne rozete u krugu, rozete sa dva koncentrična kruga, rozete u krugu kombinirane sa zrnima na unutrašnjem dijelu kruga, rozete u krugu sa slovima u kutovima itd., ako spomenemo tek nekoliko tipova. Boca iz Bakra pokazuje osmolisnu rozetu (t. 8: 6) kao i male stilizirane rozete u krugu (t. 9: 4). Usporedbi s prvim tipom je svega nekoliko, ali možemo spomenuti jednak tip rozete otkrivene na oktogonalnoj, takozvanoj pseudo-Merkur boci iz Argyruntuma.¹⁵⁶ Taj ukras je najbolja usporedba s bocom iz Bakra i možda možemo razmišljati o nekakvoj vezi u njihovoj proizvodnji. Ukras dna s drugim tipom rozete nema poznatih paralela. Boca je visoka, izrađena od stakla dobre kvalitete i primjer je izrade umješnih obrtnika. Prema detaljima na rubu i ručki može se datirati u drugu pol. 1. st. i u 2. st.

U nastavku spominjemo nekoliko fragmenata dna s rozetama pronađenim kao otpadni materijal iz dvije staklarske radionice – iz Celeije (Celje) i Poetovione (Ptuj). Proizvodnja staklarskih radionica u Celeiji pripisuje se 2. stoljeću, a možda i početku 3. stoljeća.¹⁵⁷ U Poetovionu dobar broj otpadnih fragmenata potječe od četvrtastih boca¹⁵⁸ kao i nekoliko komada gusto rebrastih ručki. Ostaci staklene proizvodnje pokazuju da su peći iz Donje Hajdine iz Ptuja bile u uporabi u 2. stoljeću, a vjerojatno i u prvoj pol. 3. st.¹⁵⁹ Oznake dna s rozetama imaju brojne analogije među materijalom iz susjedne Mađarske.¹⁶⁰ Sličnost spomenutih oznaka dna ukazuje na trgovačke veze i kontakte između panonskih gradova i mogućih trgovačkih puteva stakla iz Poetovione.

Tek na jednoj boci očuvan je otisak u obliku figuralnog motiva (t. 9: 3). Prikazuje pticu, smještenu u središtu a u kutovima su dodane četiri točke. Ptica kao motiv nije rijetko zastupljena među otiscima na posuđu, pokadkad je moguće odrediti vrste ptica ili životinja koje se pojavljuju, primjerice golubovi, pijetlovi itd. Mogu biti kombinirani s jednostavnim geometrijskim

Emona-Siscia road), we can observe that the base fragments of bottles are relatively numerous among glass finds;¹⁴⁵ and the base marks on them include relief concentric circles and also some other marks. The settlement finds from the road station at Ribnica in Dolenjska (Lower Carniola) were found in strata from the end of the 1st through the 2nd and 3rd centuries.¹⁴⁶

The graves from Emona (Ljubljana) are dated from the second half of the 1st century to the beginning of the 3rd century.¹⁴⁷ There is also an example of a skeleton burial from the end of the 3rd and beginning of the 4th century with a glass bottle.¹⁴⁸ The finds from Poetovio (Ptuj) and Neviodunum (Drnovo) are mostly old finds from the 19th century and beginning of the 20th century, and therefore only a few of them can be dated according to the known grave contexts.¹⁴⁹ Published analogies from Argyruntum and Zadar can be noted from Croatia.¹⁵⁰

The next base mark consists of dots in combination with a rhomb (p. 9: 1). The same mark appears on the base of a square bottle from grave 463 in Ptuj,¹⁵¹ dated to the second half of the 2nd and beginning of the 3rd centuries.¹⁵² Finds from Hungary are dated to the second half of the 1st century,¹⁵³ from Aquileia to the end of the 1st and into the 2nd century,¹⁵⁴ while we should also mention a distant parallel from Cesarea in Algeria.¹⁵⁵

Rosettes are also very common as base marks and several types are known: a six-leaf circular rosette, a rosette with two concentric circles, a rosette in a circle combined with grains in the inner side of the circle, a rosette in a circle with letters in the corners, to mention only several types. One bottle from Bakar (pl. 8: 6) bears an eight-leaf rosette, and another (pl. 9: 4) has a small stylized rosette in a circle. Comparisons to the first type are rare, but an identical type of rosette was discovered on octagonal, so-called pseudo-Mercury flask from Argyruntum.¹⁵⁶ This decoration is the best analogy to the bottle from Bakar and perhaps some connection could be considered in the production of these products. The base mark with the second type of rosette has no known parallels. The bottle is tall, made of good quality glass, and was made by a skilled craftsman. According to the details of the rim and the handle, it can be dated to the second half of the 1st century and in the 2nd century.

Several base fragments with rosette decoration can also be mentioned that were found as a waste material from two glass workshops – in Celeia (Celje) and Poetovio (Ptuj). Production at the glass workshop in Celeia can be assigned to the 2nd century and perhaps the beginning of the 3rd century.¹⁵⁷ At Poetovio, a fair number of waste fragments were from square bottles,¹⁵⁸ as well as several pieces of reeded handles. The remains of glass products indicate that the furnaces at Spodnja Hajdina in Ptuj were in function in the 2nd century and probably also in the first half of the 3rd century.¹⁵⁹ Base

¹⁴⁷ Plesničar Gec 1977, 19, 47.

¹⁴⁸ Plesničar Gec 1977, 40.

¹⁴⁹ Istenič 2000, 150; Lazar 2006b, SI33.

¹⁵⁰ Lazar 2006c, 273, CRO 3, 4, 6–8.

¹⁵¹ Lazar 2006b, SI36.

¹⁵² Istenič 2000, 150.

¹⁵³ Lazar 2006d, H 10.

¹⁵⁴ Mandruzzato, Marcante 2005, 71, no. 81, 82

¹⁵⁵ Foy 2006, 349, MAG-A7.

¹⁵⁶ Fadić 2005, 206, 1.15, 1.16.

¹⁵⁷ Lazar 2003, 215.

¹⁵⁸ Lazar 2003, Pl. 1: 6–8; 2: 1; 6: 11, 12.

¹⁵⁹ Lazar 2003, 230.

¹⁶⁰ Barkóczy 1988, no. 417, 424, 423, 422, 412.

¹⁴⁵ Lazar 2006b, SI 49–62; 65.

¹⁴⁶ Lazar 2006b, 245.

¹⁴⁷ Plesničar Gec 1977, 19, 47.

¹⁴⁸ Plesničar Gec 1977, 40.

¹⁴⁹ Istenič 2000, 150; Lazar 2006b, SI33.

¹⁵⁰ Lazar 2006c, 273, CRO 3, 4, 6–8.

¹⁵¹ Lazar 2006b, SI36.

¹⁵² Istenič 2000, 150.

¹⁵³ Lazar 2006d, H 10.

¹⁵⁴ Mandruzzato, Marcante 2005, 71, nos. 81, 82

¹⁵⁵ Foy 2006, 349, MAG-A7.

¹⁵⁶ Fadić 2005, 206, 1.15, 1.16.

¹⁵⁷ Lazar 2003, 215.

¹⁵⁸ Lazar 2003, Pl. 1: 6–8; 2: 1; 6: 11, 12.

¹⁵⁹ Lazar 2003, 230.

ukrasima, a nalazimo ih povezane s kraticama ili imenima proizvođača, odnosno vlasnika radionica. U tom kontekstu spominjemo C. Salvija Grata (gl. u daljnjem tekstu), koji je kratice svojeg imena kombinirao s pečatima tri različita prikaza ptica.¹⁶¹ Stoga i pečat s motivom ptice s točkama povezuju s krugom proizvoda CSG, iako na njemu ne postoje kratice imena. Identičan pečat poznajemo iz groba u Locarnu, koji pripada drugoj pol. 1. st.¹⁶²

Najzanimljiviji otisci na dnu boca su uvijek imena i njihove kratice. Ti pečati su obično kombinirani i s geometrijskim motivima, primjerice koncentrični krugovi i točke s biljnim ili figuralnim ukrasom u obliku listova, grana, životinja itd. Dvije boce iz Bakra imaju očuvan žig s imenom i stoga su još zanimljivije. Kvadratna boca ima na dnu otisak tri koncentrična kruga, srcolikih listova u kutu, a među njima su rastavljena slova C S G (t. 9: 6). U njima prepoznajemo skraćenicu imena *CAIVS SALVIVS GRATVS*, majstora ili vlasnika koji je svoje proizvode označavao s više različitih pečata i ostvario zavidan prodajni krug svojih proizvoda. Pečati sa skraćenicama u obliku slova pojavljuju se u više inačica: kombinirani su s tri kruga i srcolikim listovima u kutu, kao na bakarskoj boci, s tri različite ptice, rombom i palmetom u krugu i poluduguljasti romb s uspravnom palmetom. Posebno raznoliki pečati otkriveni su na području Recije; zato Rottloff pretpostavlja kako je riječ o samostalnim ispostavama pa se pečati pojavljuju na uvezenim i lokalnim proizvodima.¹⁶³ Vjerojatno je u primjeru Salvija Grata prije riječ o imenu vlasnika radionice nego staklarskom majstoru. Pečati su vrlo različiti i neki su tako slabo izrađeni, odnosno slova su tako nespretno napisana kao da su nastala ispod ruku jedva pismenih ili nepismenih radnika.¹⁶⁴

Proizvodi označeni tim pečatima su raznoliki, obuhvaćaju boce i žare, odnosno lonce. U ovom kontekstu spominjemo nov zanimljiv nalaz s natpisom na kvadratnom loncu¹⁶⁵ iz groba u Poetovionu. Pečat nosi natpis C. *SALVI / GRATI* i kombiniran je s tri koncentrična kruga i grančicom. Posuda je pronađena u paljevinskom grobu s lokalno izrađenom keramikom i svjetiljkama datiranim na kraj 2. stoljeća i u prvu pol. 3. st.¹⁶⁶ Natpis je otprije poznat jedino s kvadratnih boca. I svi fragmenti su bili donedavna tumačeni kao dijelovi kvadratičnih boca. Novi nalaz pokazuje i novi oblik proizvoda u krugu C. Salvija Grata.

Ime C. *Salvius Gratus* moglo bi se povezati s proizvodnjom stakla u sjevernoj Italiji. C. Calvi je prikupila sedam boca sa spomenutim pečatom u Aquileji, gdje je i pretpostavila središte proizvodnje ili sjedište radionice. Prema publikacijama CCAVV, objavljenim u rasponu od 1998. do 2004. godine, možemo dodati nova mjesta, poput Pavije, Locarna, Verone, Calvatonea, podmorskih nalaza iz Grada itd.¹⁶⁷ Ime je poznato s nalazišta u Hrvatskoj, primjerice iz Zadra.¹⁶⁸ Dalje na sjeveru, u Njemačkoj proizvode s natpisom C. S. *Gratus* prvi je put prikupio Fassold,¹⁶⁹ a poznajemo ih i iz Austrije¹⁷⁰ i Augsburga. Iz *Augusta Vindelicum* poznata su dvadeset dva (22) fragmenta s otiskom "C. *Salvius Gratus*", dio

marks with rosettes have numerous analogies among the material in neighbouring Hungary.¹⁶⁰ The similarity of the mentioned base marks indicates trade contacts and connections between the Pannonian towns and also the possible trade routes of glass from the Poetovio workshops.

A base mark in the form of a figural motif was preserved only on one bottle (pl. 9: 3). A bird was depicted in the centre, while a dot was added in each corner. As a motif, birds are not uncommon as impressions on vessels, and sometimes it is even possible to determine the species of bird or animal, such as doves, roosters, etc. They can be combined with simple geometric decorations, and they can also be tied to abbreviations or the names of producers, or workshop owners. In this context we must mention C. *Salvius Gratus* (see the text below), who combined the abbreviation of his name on the marks with three different depictions of birds.¹⁶¹ Hence the stamp with the motif of a bird and dots is related to the circle of CSG products, even lacking the abbreviation. An identical mark is known from a grave at Locarno, dated to the second half of the 1st century.¹⁶²

The most interesting base marks on bottles are always names and their abbreviations. These stamps are usually combined with geometric motifs, such as concentric circles and dots with floral or figural decoration in the form of leaves, branches, animals, and so forth. Two bottles from Bakar bear a preserved stamp with a name, and are hence particularly interesting. The square bottle has a base mark of three concentric circles, with heart-shaped leaves in the corners, and between them the separate letters C S G (pl. 9: 6). These can be recognized as the abbreviation of the name *CAIVS SALVIVS GRATVS*, a craftsman or owner who marked his products with several different stamps and achieved an enviable market for his goods. Stamps with abbreviations in the form of letters appeared in several variants: combined with three circles and heart-shaped leaves in the corners, like on the bottle from Bakar, with three different birds, a rhomb and palmette in a circle, and an oblong rhomb with an upright palmette. Particularly diverse stamps were discovered in the region of Rhaetia, hence Rottloff hypothesized that these were independent branches, and the stamps appeared both on imported and local products.¹⁶³ In the case of *Salvius Gratus*, it is more likely that this was the name of the owner of a workshop than a master glass-worker, as the stamps are highly varied and sometimes so poorly made and the letters so awkwardly written that they could only have been created by the hand of a barely literate or illiterate worker.¹⁶⁴

The products marked with these stamps are diverse, including both bottle and jars. In this context we should mention an interesting new find of an inscription on a square jar from a grave at Poetovio.¹⁶⁵ The stamp bears the letters C. *SALVI / GRATI* and is combined with three concentric circles and a branch. The vessel was found in a cremation grave with locally produced pottery and oil lamps dated to the end of the 2nd century or first half of the 3rd century.¹⁶⁶ Such an inscription was previously known only from square bottles. And all such fragments were until recently interpreted as parts of square bottles. The new find points to new form of production in the workshops of C. *Salvius Gratus*.

¹⁶¹ Rottloff 2006, 146, taf. 9.

¹⁶² Biaggio Simona 1991, 183–185, tav. 35: 134.2.048; Amrein 2006, 209, pl. 6: CH30; id. 1991, 185.

¹⁶³ Rottloff 2006, 146, D-RA2, 191, 51, 158.

¹⁶⁴ Rottloff 2006, 146.

¹⁶⁵ Lazar 2006b, 247, SI81.

¹⁶⁶ Lazar 2006b, 247, 260.

¹⁶⁷ Buora 2004, 152.

¹⁶⁸ Gluščević 1991, 190; Buljević 2005b, 95.

¹⁶⁹ Fassold 1985, 197.

¹⁷⁰ Glöckner 2006, 187, AUS 62.

¹⁶⁰ Barkóczy 1988, nos. 417, 424, 423, 422, 412.

¹⁶¹ Rottloff 2006, 146, pl. 9.

¹⁶² Biaggio Simona 1991, 183–185, pl. 35: 134.2.048; Amrein 2006, 209, pl. 6: CH30; id. 1991, 185.

¹⁶³ Rottloff 2006, 146, D-RA2, 191, 51, 158.

¹⁶⁴ Rottloff 2006, 146.

¹⁶⁵ Lazar 2006b, 247, SI81.

¹⁶⁶ Lazar 2006b, 247, 260.

fragmenata pripada otpadu od proizvodnje.¹⁷¹ Iznimno raznoliki pečati SCG i pečati iz njegova kruga prikupljeni su u Reciji.¹⁷² Prema brojnim novim nalazima, hipoteza o sjedištu u Aquileiji više nije toliko pouzdana. Sudeći prema najnovijim nalazima, možemo govoriti o radionicama specijaliziranim za izradu transportnih i pohrambenih posuda, poput boca i lonaca. Vjerojatno nije riječ o tek jednoj radionici koja je djelovala u sjevernoj Italiji, već o nekoliko grana organiziranih u drugim provincijskim središtima na sjeveru (i istoku) od njegova sjedišta.

Druga boca nosi natpis *L. Aemilius Blastus*, koji je na žigu skraćen u LA/EM/IBL/ASI, u sredini je dopunjen s tri koncentrična kruga i četiri točke na kutovima (t. 9: 5). Krugovi koje je utisnuo vrlo su slični pečatu C. S. Grata, iako svoje oznake nije kombinirao s listovima i palmetama. Do sada je najviše njegovih pečata otkriveno u Italiji,¹⁷³ šest u Reciji,¹⁷⁴ jedan u Mađarskoj¹⁷⁵ i, ako uzmemo u obzir nalaz iz Bakra, dva u Hrvatskoj.¹⁷⁶ I Lukij Emilij Blastus bio je italski poduzetnik, koji je svoje djelovanje proširio na više strana imperija, a zasada pokazuje da se osim na zapad usmjerio i prema istoku i jugu.

Boce pravokutno oblikovanih stijenki nisu tako česte kao kvadratne boce. Boca iz Bakra (t. 9: 2) je gotovo minijturni proizvod, ima dvije ručke, na stijenkama je na većim stranicama vidljiv otisak dva cilindrična kruga, dno pak nosi dekoraciju s pet točaka. Obliku ne nalazimo veliki broj usporedba. Najbližu možemo prvo potražiti u Hrvatskoj i Mađarskoj te u Sloveniji. Prema obliku i ukrasu istovjetni su nalaz s Cresa¹⁷⁷ i bočica iz Budimpešte, koja je datirana u 2. stoljeće.¹⁷⁸

U Poetovionu, minijturna pravokutna boca¹⁷⁹ izrađena od prirodnog stakla pronađena je u jednom od grobova južne nekropole (grob 56). Dno je ukrašeno sa četiri točke u kutovima i koncentričnim krugom. Ženski grob sadržavao je jantarne perle, par srebrnih naušnica, drvenu škrinju i dvije staklene posude. Mala pravokutna bočica dodana je u grob zajedno s globularnom bocom i udubljenjima na tijelu (Is 103). Boca je vrsno načinjena i izrađena od bezbojnog stakla. Grob je moguće datirati u prvu pol. 3. st. Minijturne posude pronađene su u raznim grobovima iste nekropole.¹⁸⁰ Izrađivane su od bezbojnog stakla i njihovi oblici su bili savršene kopije većih posuda poznatijih u tipologiji materijala iz Poetovione (br. 74 je identičan oblicima 6.2.4.).¹⁸¹

Drugi je nalaz tek fragment dna¹⁸² malene pravokutne boce iz Ribnice; otisak čine dva polukruga na kraćim stranama boce okrenutim prema središtu. Između oba polukruga nalazi se križ (?) ili rozeta sa četiri lista. Fragment je pronađen u naseobinskom sloju s keramičkim nalazima iz 2. stoljeća.¹⁸³

Sam motiv ukrasa bakarske boce, odnosno pečata na dnu s pet točaka je donekle čest i nalazimo ga na kvadratnim i pravokutnim

The name of *C. Salvius Gratus* could be perhaps connected with glass production in northern Italy. C. Calvi collected seven bottles with this stamp in Aquileia and presumed this to be the production centre or seat of this workshop. From the CCAVV publications published from 1998 to 2004, we can add new find spots such as Pavia, Locarno, Verona, Calvatone, underwater finds from Grado, etc.¹⁶⁷ The name is also known from sites in Croatia, such as Zadar.¹⁶⁸ Further to the north, in Germany, products with the legend *C. S. Gratus* were first gathered by Fassold,¹⁶⁹ and they are also known from Austria¹⁷⁰ and Augsburg. From *Augusta Vindelicum* come twenty-two (22) fragments with the base mark »C. Salvius Gratus«, some of the fragments being production debris.¹⁷¹ An exceptional variety of these stamps and base marks from this circle have been gathered in Rhaetia.¹⁷² The hypothesis about a production centre in Aquileia no longer seems so certain. Judging from the most recent finds, these were workshops specialized for the production of transport and storage vessels, such as bottles and jars. Most likely this was not a single workshop operating in northern Italy, but rather several branches organized in other provincial centres to the north (and east) of its seat.

The second bottle bears the inscription of *L. Aemilius Blastus*, abbreviated on the stamp as LA/EM/IBL/ASI, further decorated with three concentric circles in the centre and four dots, one in each corner (pl. 9: 5). The stamped circles are very similar to the mark of C. S. Gratus, although they were not combined with leaves and palmettes. So far, most of his stamps have been found in Italy,¹⁷³ six in Rhaetia,¹⁷⁴ one in Hungary,¹⁷⁵ and if the find from Bakar is taken into consideration, two in Croatia.¹⁷⁶ Lucius Aemilius Blastus was also an Italic entrepreneur, who expanded his activities throughout the Empire, including the east and south.

Bottles with a rectangular body are not as common as those with square body. The bottle from Bakar (pl. 9: 2) is an almost miniature product, with two handles, and on the larger sides of the walls the impression of two cylindrical circles can be seen, while the base has a decoration of five dots. Not many analogies to the form can be found. The closest can be sought in Croatia, Hungary, and Slovenia. In terms of the form and decoration, an identical find comes from Cres,¹⁷⁷ along with a small bottle from Budapest, which is dated to the 2nd century.¹⁷⁸

In Poetovio, a miniature rectangular bottle made of natural glass was found in one of the graves in the southern necropolis (grave 56).¹⁷⁹ The base is decorated with four dots, one in each corner, and a concentric circle. This female grave contained amber beads, a pair of silver earrings, a wooden chest, and two glass vessels. A small rectangular bottle was added to the grave together with a globular bottle with a constriction on the neck and indentations on the body (Isings 103). The bottle was excellently made and produced from colourless glass. The grave can be dated to the first half of the 3rd

¹⁷¹ Rottloff 1999, 189–192.

¹⁷² Rottloff 2006, 163–164.

¹⁷³ Ceselin 1997, 33–36.38

¹⁷⁴ Rottloff 2006, 147, D-RA 1, 104, 122, 204, 216, 217.

¹⁷⁵ Barkóczy 1988, no. 413.

¹⁷⁶ Asseria ili Zadar; Fadić 1997, no. 56; Trasparenze 1998, no. 125.

¹⁷⁷ Fadić 1995, 185; Lazar 2006c, 273, CRO18.

¹⁷⁸ Barkóczy 1988, 161, no. 370.

¹⁷⁹ Lazar 2004, 72; 2006b, SI66.

¹⁸⁰ Lazar 2004b, 72, br. 74–77.

¹⁸¹ Lazar 2003, 140, Fig. 41.

¹⁸² Lazar 2006b, SI65.

¹⁸³ Lazar 2006b, 252.

¹⁶⁷ Buora 2004, 152.

¹⁶⁸ Gluščević 1991, 190; Buljević 2005b, 95.

¹⁶⁹ Fassold 1985, 197.

¹⁷⁰ Glöckner 2006, 187, AUS 62.

¹⁷¹ Rottloff 1999, 189–192.

¹⁷² Rottloff 2006, 163–164.

¹⁷³ Ceselin 1997, 33–36.38

¹⁷⁴ Rottloff 2006, 147, D-RA 1, 104, 122, 204, 216, 217.

¹⁷⁵ Barkóczy 1988, no. 413.

¹⁷⁶ Asseria or Zadar; Fadić 1997, no. 56; Trasparenze 1998, no. 125.

¹⁷⁷ Fadić 1995, 185; Lazar 2006c, 273, CRO18.

¹⁷⁸ Barkóczy 1988, 161, no. 370.

¹⁷⁹ Lazar 2004, 72; 2006b, SI66.

bocama. Spomenimo usporedbu iz Emone,¹⁸⁴ jednak motiv na kvadratnom loncu iz Sirije¹⁸⁵ i Merkur bočici iz Brigetia, koja je datirana u prvu pol. 3. st.¹⁸⁶

Cilindrične boce s ručkama bile su, ponajprije, posude za uporabu namijenjeno pohrani, a pojavile su se kao niska ili visoka inačica (sl. 9 – lijevo). Niski oblici koji često imaju kraći, širi vrat i veći otvor bili su primjereni za tekuće i suhe tvari, a viši oblici bili su pretežno namijenjeni prenošenju tekućina. Najstariji primjerci tog oblika pojavljuju se prije 79. godine, a u uporabi su bili još dugo u kasno rimsko doba (primjerice oblik Is 126). Brojne lokalne inačice, koje se pokazuju u oblikovanju oboda, ručki i ukrasa govore kako je riječ o proizvodu koji je nastao u staklarskim središtima širom imperija. U istočnosredozemnim radionicama su cilindrične boce slobodno puhanе, u radionicama zapadnog dijela imperija su pak rabili glatke drvene kalupe, što se prepoznaje u blagom rebru među stijenjkama i ramenom posude, gdje završava gornji rub kalupa.¹⁸⁷

Jedini primjer niske cilindrične boce (t. 10: 1) s bikonusno oblikovanim stijenjkama uspoređujemo s nalazima iz Italije (oblik Is 51a). Tamo su potonje brojno zastupljene, njihova visina varira između 11 i 22 cm, a pojedini predmeti su niži i dosežu do 10 cm u visinu.¹⁸⁸ Na zapadnom dijelu cisalpinskog područja su tako česte da postoji pretpostavka o lokalnoj proizvodnji. Najstariji nalazi datirani su još u tiberijsko razdoblje, na Magdalensbergu su se prvi nalazi tih oblika mogli pojaviti još u augustovskome vremenu.¹⁸⁹ Prvi predmeti izrađeni su i od prirodnog i obojenog stakla, potom su prevladali proizvodi od prirodno obojenog stakla, koji su više piriformnih, odnosno bikonusnih oblika i bili su rašireni kroz cijelo 1. stoljeće i na početku 2. stoljeća.¹⁹⁰

Visoka boca s dvije ručke (t. 11: 2) i dnom oblikovanim u nogu te profiliranim ručkama je kvalitetan proizvod sa četiri vodoravne linije na stijenjkama koje omeđuju tanko brušene crte. Širok rub s naborom, koji je svinut prema dolje, prema gore i prema van, vodoravno, kako bi stvorio rub (sl. 11) značajka je predmeta sa istoka. Više istočnih sredozemnih radionica na području Cipra, Male Azije i područja Crnog mora, koje nažalost nisu precizno locirane, procvjetale su u razdoblju kada se slobodno puhanje nezadrživo širilo po zapadnom dijelu imperija.¹⁹¹ Boca po obliku podsjeća na amfore, odnosno male amforiske, koje su izrađivale istočnosredozemne radionice.¹⁹² Potpuno joj je srodna i oslikana amfora iz Kerča, koja je sa svojih 20 cm točno upola manja od boce iz Bakra koja mjeri 40 cm u visinu.¹⁹³ Ukrašen kombinacijom kanelira i plitko brušenog ukrasa lako uspoređujemo s proizvodima iz 1. i 2. stoljeća jer se pojavljuje na različitim oblicima boca, vrčeva itd.¹⁹⁴ Oblik doduše podsjeća na formu Is 156; odnosno AR 175;¹⁹⁵ ali bakarska boca ipak ima drukčije oblikovani obod i naglašeno dno u obliku noge. Najbolje je opredjeljuje ravan, već opisan obod u obliku ovratnika, što je značajno za proizvode s područja istočnog Sredozemlja od

century. Miniature vessels were found in various graves of the same necropolis.¹⁸⁰ They were all made of colourless glass and their forms were perfect copies of larger vessels known from the typology of the Poetovio material (no. 74 is identical to the form 6.2.4).¹⁸¹

The second find is only a base fragment of a small rectangular bottle from Ribnica,¹⁸² and the stamp consists of two semicircles on each shorter side of the bottle facing the centre. Between both semicircles is a cross (?) or a four-leaf rosette. The fragment was found in a settlement layer together with pottery finds from the 2nd century.¹⁸³

The motif of the decoration or the base mark with five dots is relatively common and can be found on both square and rectangular bottles. An analogy can be cited from Emona,¹⁸⁴ along with an identical motif on a square jar from Syria,¹⁸⁵ and a Mercury flask from Brigetio, which is dated to the first half of the 3rd century.¹⁸⁶

Cylindrical bottles with handles were primarily vessels intended for storage, and they appeared in short or tall variants (fig. 9 – left). The short forms, which often had a shorter and wider neck and a larger opening were suitable both for liquid and dry substances, while the taller forms were primarily intended for transporting liquids. The earliest examples of this form appear even before AD 79, and remain in use for a long time into the late Roman period (such as form Is 126). The numerous local variants, which can be distinguished on the basis of the formation of the rim, handle, and decoration, indicate that this was a product created in glass centres throughout the Empire. Cylindrical bottles were free-blown in the eastern Mediterranean workshops, while in the workshops of the western part of the Empire they used smooth wooden moulds, as can be noted from the slight rib between the walls and the shoulder of the vessel, where the upper edge of the mould ended.¹⁸⁷

The only example of a short cylindrical bottle (pl. 10: 1) with somewhat biconical walls (squat bottle) can be compared to finds from Italy (form Is 51a). They are fairly numerous there, and their height varies between 11 and 22 cm, while individual examples are even lower and reach only 10 cm in height.¹⁸⁸ They are so common in the western part of the Cisalpine region that local production has been hypothesized. The earliest finds are dated as early as the Tiberian period, and the first finds of this form at Magdalensburg could even be from the Augustan period.¹⁸⁹ The first products were made from both natural and coloured glass, followed by those produced exclusively from naturally coloured glass, which were more pear-shaped or biconical and were widespread throughout the 1st century, and at the beginning of the 2nd century.¹⁹⁰

A tall bottle with two profiled handles (pl. 11: 2) and a base formed into an open foot is a high quality product with four horizontal grooves on the walls bordered by light incisions. The broad folded rim, bent down, up and out to form a collar rim (fig. 11), is a characteristic of eastern products.

Several eastern Mediterranean workshops in the region of Cyprus, Asia Minor, and the Black Sea, which unfortunately have not been

¹⁸⁴ Lazar 2006b, 245, S15.

¹⁸⁵ Nenna 2006, 431, PO-SY62.

¹⁸⁶ Barkóczy 1988, 131, no. 267.

¹⁸⁷ Stern 2001, 51.

¹⁸⁸ Biaggio Simona 1991, 173, no. 176.2.135.

¹⁸⁹ Biaggio Simona 1991, 176; Czurda-Ruth 1979, 131, no. 1013.

¹⁹⁰ Biaggio Simona 1991, 176.

¹⁹¹ Stern 2001, 40.

¹⁹² Vessberg 1956, 151, fig. 47: 25.

¹⁹³ Sorokina 1993, 59; Rütli 2003, 352, fig. 8.

¹⁹⁴ vidi npr. Stern 2001, no. 37–39; Biaggio Simona 1991, 188, no. 163.1.001, 176.1.001.

¹⁹⁵ Rütli 1991, 57.

¹⁸⁰ Lazar 2004b, 72, nos. 74–77.

¹⁸¹ Lazar 2003, 140, Fig. 41.

¹⁸² Lazar 2006b, S165.

¹⁸³ Lazar 2006b, 252.

¹⁸⁴ Lazar 2006b, 245, S15.

¹⁸⁵ Nenna 2006, 431, PO-SY62.

¹⁸⁶ Barkóczy 1988, 131, no. 267.

¹⁸⁷ Stern 2001, 51.

¹⁸⁸ Biaggio Simona 1991, 173, no. 176.2.135.

¹⁸⁹ Biaggio Simona 1991, 176; Czurda-Ruth 1979, 131, no. 1013.

¹⁹⁰ Biaggio Simona 1991, 176.



Sl. 11 Cilindrična boca sa dvije ručke | Fig. 11 *Cylindrical bottle with two handles*

posljednje četvrtine 1. stoljeća nadalje.¹⁹⁶ Nalazi su grupirani na Cipru, u Maloj Aziji i Grčkoj te na sjevernoj i zapadnoj obali Crnog mora. Oblik oboda se lako uspoređuje s keramičkim i metalnim posuđem iz pergamonskih radionica; zato se pojavila hipoteza da su te staklene posude izrađivale radionice stakla na širem području Pergamona.¹⁹⁷ Nalazi zasada te pretpostavke još nisu potvrdili. Bocu iz Bakra bi dakle na osnovi njenog značaja lako uvrstili na kraj 1. ili u prvu pol. 2. st.

Boce s urezanim ukrasom vodoravnih linija brojčano su dobro zastupljene među građom iz Bakra (5 kom.; tab. 10, 11). Riječ je o mlađoj varijanti cilindričnih boca, koje su izrađivane većinom od dekoloriranog stakla i u uporabi su bile kao stolno posuđe.¹⁹⁸ U modu su ušle potkraj 2. stoljeća. Boce imaju ljevasto oblikovan obod s rubom svinutim prema dolje i potom prema gore, kratak vrat i gotovo vodoravno rame. Stijenke se prema dnu blago sužavaju u donekle udubljeno dno. Posude su ukrašene pojedinačnim urezanim linijama ili gušćim pojasevima linija. Ručka, koja je pod oštrim kutom prelomljena, u većini je primjera gusto rebrasta.

U Britaniji su se te boce pojavljivale na nalazištima od kasnog 2. do ranog 3. stoljeća.¹⁹⁹ Poznajemo ih iz Kölna i Nida-Hedderheim,²⁰⁰ gdje njihova uporaba nije trajala dalje od prve pol. 3. st. Treba spomenuti nalaze boca iz Ticina većeg formata s pojedinačnim kanelirama po stijenkama,²⁰¹ koje su radile lokalne radionice sjeverne Italije još od 1. stoljeća. Njima je srodna boca iz Bakra pod inv. brojem 11007 (t. 10: 3), izrađena od zelenkastog stakla i malo debljih stijenki i mogli bismo je usporediti s nalazima iz Italije koji su tijekom 2. stoljeća već nestali iz upotrebe.²⁰²

Kuglaste boce su čest i raširen oblik i bolji proizvodi su se već u prvih nekoliko stoljeća upotrebljavali i kao stolno, a ne tek kao posuđe za pohranu. Precizno opredjeljujemo dvije gotovo u cijelosti očuvane boce.

Prva pripada obliku Is 103, za koju je značajna profilacija na prijelazu vrata u stijenku i sužen, ravno odrezan obod (t. 12: 1). Te boce raširen su i značajan oblik kasnorimskog doba. Izrađene su od prirodno obojenog ili bezbojnog stakla. Kvalitetniji proizvodi imaju stijenke ukrašene brušenim vodoravnim pojasevima, geometrijskim ukrasima ili figuralnim motivima, a neke krase i različiti natpisi.²⁰³ Kao primjer spomenimo nalaze iz grobova u Trieru (oblik 93), datirane u drugu pol. 3. i prvu pol. 4. st.²⁰⁴ Nalazi iz Kölna datirani su pretežno u drugu pol. 3. st.²⁰⁵ Novi grobni nalazi sa istog nalazišta govore da dosežu vremenski raspon sve do prve pol. 4. st.²⁰⁶ Dvije bočice iz Celja pripadaju kasnorimskom grobu s kraja 3. ili početka 4. stoljeća.²⁰⁷ Bočica iz Ptuja s brušenim ukrasom krugova i vodoravnih kanelira iz groba prve pol. 3. st. vjerojatno je import iz kölnskih radionica.

precisely located, flourished in the period when free blowing irrepressibly spread throughout the western part of the Empire.¹⁹¹ The shape of the bottle is reminiscent of an amphora, or rather the small amphorae produced by the eastern Mediterranean workshops,¹⁹² and a painted amphora (*amphoriskos*) from Kertch (Ukraine) is quite similar, measuring with its 20 cm exactly half of the height of the 40 cm tall bottle from Bakar.¹⁹³ The decoration with its combination of grooves and shallow incisions can be compared to products of the 1st and 2nd centuries, as it appears on various forms of bottles, jugs, etc.¹⁹⁴ The form is otherwise reminiscent of the form Is 156 or AR 175,¹⁹⁵ but the bottle has a differently formed rim and emphasized open foot. It is best to assign it to the previously described collar rim form, which was characteristic for products from the region of the eastern Mediterranean from the last quarter of the 1st century onwards.¹⁹⁶ Finds are concentrated on Cyprus, in Asia Minor and Greece, and along the northern and western coasts of the Black Sea. The rim shape can be compared to that on pottery and metal vessels from the Pergamon workshops, and hence the hypothesis was set forth that such glass vessels had been produced at glass workshops in the broader area of Pergamon.¹⁹⁷ The finds have not yet confirmed this hypothesis. The bottle from Bakar on the basis of its characteristics can be assigned to the end of the 1st century or in the first half of the 2nd century.

Bottles with incised and grooved decoration of horizontal lines are well represented among the material from Bakar (5 examples; pl. 10, 11). These were late variants of the cylindrical bottles, mostly made from decoloured glass and used as tableware.¹⁹⁸ They became popular at the end of the 2nd century. The bottles have funnel shaped mouths with the rim bent down and then up, a short neck, almost horizontal shoulders, and walls that slightly narrow towards the somewhat concave base. The vessels are decorated with individual incised or grooved lines or denser bands of lines. The handle, which was bent at a sharp angle, was most often densely ribbed or reeded.

These bottles appear at sites in Britannia from the late 2nd to the early 3rd centuries.¹⁹⁹ They are known on the European continent from Köln and Nida-Hedderheim,²⁰⁰ where their use does not extend further than the first half of the 3rd century. Finds of bottles from Ticino should be noted, of larger format with individual grooves on the walls,²⁰¹ produced by local northern Italian workshops from the 1st century onwards. One bottle from Bakar is similar, inv. no. 11007 (pl. 10: 3), made of greenish glass with somewhat thicker walls, which can be compared to finds from Italy that already begin to disappear from use during the 2nd century.²⁰²

Globular bottles are a common and widespread form and several well-made products were already used in the first centuries as tableware and not merely as storage vessels. Only two almost entirely preserved bottles can be classified precisely.

¹⁹⁶ Stern 2001, 48.

¹⁹⁷ Stern 2001, 50.

¹⁹⁸ Lazar 2003, 155, oblik 6.3.6.

¹⁹⁹ Cool, Price 1995, 200.

²⁰⁰ Welker 1974, 137, no. 302.

²⁰¹ Biaggio Simona 1991, 188, no. 163.1.001, 176.1.001.

²⁰² Biaggio Simona 1991, 188.

²⁰³ Harden *et al.* 1988, 208, sl. 116; Fünfschilling 1999, 81, Abb. 6.

²⁰⁴ Goethert-Polaschek 1977, 351.

²⁰⁵ Fremersdorf, Polónyi-Fremersdorf 1984, 36–39.

²⁰⁶ Friedhoff 1991, 158.

²⁰⁷ Lazar 1997, 326.

¹⁹¹ Stern 2001, 40.

¹⁹² Vessberg 1956, 151, fig. 47: 25.

¹⁹³ Sorokina 1993, 59; Rütli 2003, 352, fig. 8.

¹⁹⁴ See Stern 2001, nos. 37–39; Biaggio Simona 1991, 188, no. 163.1.001, 176.1.001.

¹⁹⁵ Rütli 1991, 57.

¹⁹⁶ Stern 2001, 48.

¹⁹⁷ Stern 2001, 50.

¹⁹⁸ Lazar 2003, 155, form 6.3.6.

¹⁹⁹ Cool, Price 1995, 200.

²⁰⁰ Welker 1974, 137, no. 302.

²⁰¹ Biaggio Simona 1991, 188, nos. 163.1.001, 176.1.001.

²⁰² Biaggio Simona 1991, 188.

Druga ptujska bočica s pojasevima horizontalnih brušenih linija pripada grobu koji datiramo na završetak 3. stoljeća.²⁰⁸

Srodna po obliku, iako bolje kvalitete izrade, jest bočica od dekoloriranog stakla na posebno puhanj nozi (t. 12: 4). Kuglaste stijenke i vrat, koji se prema obodu unekoliko širi, krasi plitke kose kanelire (optičko puhanje) i dvije profilacije na vratu. Noga je bila zasebno puhana i nataljena na donji dio posude koja je iznimno tanko puhana. Po obliku i ukrasu slična joj je boca iz Fažane koja se čuva u pulskome muzeju, iako se njezina lokalna izrada kvalitetom ne može usporediti s proizvodom iz groba u Bakru.²⁰⁹ Potonju bismo s obzirom na detaljnu izradu datirali u 2. ili 3. stoljeće.

The first belongs to form Is 103, with its characteristic constriction at the transition from the neck to the body, and a narrowed, cut-off rim (pl. 12: 3). Such bottles are a widespread and characteristic form of the late Roman period. They are made of naturally coloured or colourless glass. Higher quality products have walls decorated with incised horizontal bands, geometric ornaments, or figural motifs, while some also bear various legends.²⁰³ Analogies are finds from graves in Trier (form 93), dated to the second half of the 3rd and first half of the 4th centuries,²⁰⁴ while finds from Köln are dated primarily to the second half of the 3rd century.²⁰⁵ New grave finds from the same site indicate that the chronological span here also extends into the first half of the 4th century.²⁰⁶

Two small bottles from Celje come from a Late Roman grave from the end of the 3rd or beginning of the 4th century.²⁰⁷ A small bottle from Ptuj with a wheel-cut decoration of circles and horizontal grooves from a grave dated to the first half of the 3rd century was probably an import from the Köln workshops. A second bottle from Ptuj with bands of horizontal incised lines was found in a grave that is dated to the end of the 3rd century.²⁰⁸

Similar in terms of shape, although of better workmanship, is a bottle of decoloured glass on a separately blown foot (pl. 12: 4). The globular body and the neck that widens slightly towards the rim are decorated with shallow oblique channels (optical blowing) and two constrictions on the neck. The foot was blown separately and attached to the lower part of the vessel, which was quite thinly blown. A similar bottle in terms of shape and decoration comes from Fažana, and is stored in the Archaeological Museum in Pula, although its local workmanship cannot compare in quality to the product found in a grave at Bakar.²⁰⁹ The latter could be assigned on the basis of details of the workmanship to the 2nd or 3rd centuries.

Žare ili lonci

Među priloženim žarama u grobovima Volcere očuvano je pet komada koji pripadaju dvijema inačicama (okrugle i kvadratne posude), pokrov je vjerojatno dio jedne od neočuvanih posuda. Kuglaste posude sa široko izvučenim obodom i udubljenim dnom su među staklenim proizvodima česte i proširene. Inače dijelimo prema obliku i izradi oboda koji je izvučen i potom svinut na više načina. Izradili su ih u više veličina i vjerojatno su ih upotrebljavali za različite namjene, a veće su najčešće služile kao žare. Kako potvrđuju nalazi iz gradova, npr. Pompeja i Herkulanuma često su ih upotrebljavali i u domaćinstvu kao posude za pohranu.²¹⁰

Osim jednostavnih kuglastih posuda bez ručki prošireni su proizvodi s dvjema ručkama različitih oblika (oblik Is 63 i 65).

Ponajprije proizvodi iz 1. i 2. stoljeća imaju ponekad dodan stakleni poklopac. U rijetkim je primjerima poklopac oblikovan kao lijevak koji je služio pri pogrebnim svečanostima.²¹¹ Položili bi ga na obod žare sa cjevčicom prema dolje i u posudu su ulijevali darove namijenjene pokojniku.²¹² Kad su se raširili skeletni pokopi, od 3. stoljeća, uporaba u pogrebnim običajima počela je zamirati, dok su kao posude za pohranu upotrebljavane i u mlađem dobu.²¹³ Najstariji predmeti oblika Isings 67 poznati

Jars

Among the jars placed in graves at *Volcera*, five examples were preserved that belonged to two variants (globular and square vessels), while the lid was probably part of one of the unpreserved vessels. Globular vessels with a broad everted rim and a concave base are common and widespread among glass products. The variants are classified according to the form and workmanship of the rim, which is everted and then bent in various manners. They were produced in many sizes and were probably used for various purposes, the larger ones most often serving as urns. As is confirmed by finds from cities like Pompeii and Herculaneum, they were also often used in households as storage vessels.²¹⁰

In addition to the simple globular vessels without handles, examples were also widespread with two handles of various forms (forms Is 63 and 65). Products from the 1st and 2nd centuries in particular sometimes had a glass lid added. In rare examples, the lid was shaped like a funnel to serve in funerary ceremonies.²¹¹ It would be placed on the rim of the urn with the funnel facing down, and gifts

²⁰⁸ Istenič 2000, 203; Tušek 1985, 242.

²⁰⁹ Trasparenze 1998, 144, no. 101.

²¹⁰ Scattozza-Höricht 1986, 68–70.

²¹¹ Whitehouse 1997, no. 302.

²¹² Whitehouse 1997, 172.

²¹³ Cool, Price 1995, 110.

²⁰³ Harden *et al.* 1988, 208, fig. 116; Fünfschilling 1999, 81, fig. 6.

²⁰⁴ Goethert-Polaschek 1977, 351.

²⁰⁵ Fremersdorf, Polónyi-Fremersdorf 1984, 36–39.

²⁰⁶ Friedhoff 1991, 158.

²⁰⁷ Lazar 1997, 326.

²⁰⁸ Istenič 2000, 203; Tušek 1985, 242.

²⁰⁹ Trasparenze 1998, 144, no. 101.

²¹⁰ Scattozza-Höricht 1986, 68–70.

²¹¹ Whitehouse 1997, no. 302.

su sa Magdalensberga iz sredine 1. stoljeća.²¹⁴ Tijekom druge pol. 1. i do početka 3. st. česti su na mnogim nalazištima zapadnog dijela imperija. I nalazi iz slovenskog prostora su većinom dijelovi grobnih cjelina; međutim, iz naseobinskih slojeva poznajemo ih vrlo malo.²¹⁵ Nalazi iz naselja su zbog fragmentarne očuvanosti teže prepoznatljiviji, odnosno teže se određuju.

Žare iz Bakra (t. 13: 1, 2) pripadaju obliku Is 67a, odnosno 7.2.3. u Sloveniji.²¹⁶ Oblik 7.2.3. pojavljuje se u grobnim cjelinama druge pol. 1. st. i u 2. stoljeću, a iznimno još i na početku trećega. Najstariji je grob iz Šempetra, u kojem je pronađen Augustov novac.²¹⁷ Žare iz gomile u Miklavžu su dio cjeline s kraja 1. i početka 2. st.²¹⁸ Žare iz Poetovione pripadaju grobnim cjelinama iz 2. stoljeća.²¹⁹ Najmlađe su žare iz groba u Šahovcu i groba 1 u Šempetru, koje pripadaju u drugu pol. 2. odnosno na početak 3. st.²²⁰ Brojne usporedbe s hrvatskih nalazišta pokazuju jednak vremenski raspon uporabe.²²¹

Pokrov kupolastog oblika, kojem nedostaje završetak oblika puceta je najvjerojatnije pripadao (nažalost nije očuvana) žari s dvije ručke kojoj nalazimo brojne paralele. Spomenimo one najbliže: u Emoni poznajemo više vrsta žara s ručkama i poklopcima. U grobovima 109 i 746 (datiranima novcem Nerona) pronađene su žare s ručkama, iz grobova 732 i 734 očuvane su žare s poklopcima.²²² S hrvatskih nalazišta poznajemo brojne primjere u Zadru, Murteru, Argyruntumu i još ponegdje.²²³ Prema usporedbama, poklopac bismo mogli datirati u drugu pol. 1. i u 2. st.

Oba kvadratna lonca imaju širok, prema dolje cjevasto svinut rub i na dnu otisak koncentričnih krugova (t. 13: 4; 14: 1). Pripadaju obliku 7.1.4. po tipologiji za Sloveniju.²²⁴ Datirane grobne cjeline pokazuju da su se kvadratni lonci počeli pojavljivati od druge pol. 1. st. i da su najrašireniji bili u 2. stoljeću.²²⁵ Lonci su prvenstveno služili za pohranu, a oblik je posebno prilagođen i za transport (sl. 12). Kao žare su upotrebljavani od 2. stoljeća, a na početku 3. stoljeća uporaba kvadratnih lonaca počela je polako zamirati.

I otisci na dnu tih lonaca su prilično česti. Oznake na dnu uključuju nekoliko tipova: krugove, kvadrate, rozete s lišćem i otisci s imenom na dnu. Posude s koncentričnim krugovima zastupljene su u većem broju u grobovima Emone.²²⁶ Na četiri vrča su otisci dva, pet ili sedam koncentričnih krugova. Usporedbe su poznate i među neobjavljenim materijalom iz grobova kraj Slovenijalesa (gr. 2 s vespazijanskim novčićem, gr. 21).²²⁷ Na osnovi grobnih priloga možemo datirati grobove u drugu pol. 1. st. i u 2. st. Iz

intended for the deceased would be poured in.²¹² Parallel with the increase in skeleton burial from the 3rd century onwards, their use in burial rituals died off, but they were still in use as storage in later periods.²¹³ The earliest examples of form Isings 67 are known from Magdalensberg from the middle of the 1st century,²¹⁴ while from the second half of the 1st century up to the beginning of the 3rd century they are frequent at many sites in the western part of the Empire. The finds from Slovenia are also mostly parts of grave units, while very few are known from settlement contexts.²¹⁵ Finds from settlements are also more difficult to recognize and determine because of fragmentation.

The urns from Bakar (pl. 13: 1, 2) belong to form Is 67a, or form 7.2.3 in Slovenia.²¹⁶ Form 7.2.3. appears in grave units of the second half of the 1st and in the 2nd century, and exceptionally further at the beginning of the 3rd century. The earliest is a grave from Šempeter, in which a coin of Augustus was found.²¹⁷ The urns from the tumulus at Miklavž were part of a grave unit from the end of the 1st and beginning of the 2nd century,²¹⁸ while the urns from Poetovio belong to grave units from the 2nd century.²¹⁹ The latest are urns from a grave at Šahovec and grave 1 at Šempeter, dated to the second half of the 2nd and the beginning of the 3rd century, respectively.²²⁰ The numerous comparisons at Croatian sites indicate an identical chronological span of use.²²¹

A domed lid, missing its button-shaped top, most probably belonged to a jar with two handles (unfortunately not preserved) for which numerous parallels are known. To mention merely the nearest, several types of urns with handles and lids are known from Emona. Graves 109 and 746 (dated by a coin of Nero) contained urns with handles, while from graves 732 and 734 were preserved urns with lids.²²² Numerous examples are known from Croatian sites: Zadar, Murter, Argyruntum, and elsewhere.²²³ On the basis of comparisons the lid could be dated to the second half of the 1st century and the 2nd century.

Both square jars have a wide downward rolled tubular rim and an impression of concentric circles on the base (pl. 13: 4; 14: 1). They belong to type 7.1.4. according to the typology for Slovenia.²²⁴ Dated grave units show that square jars appeared from the second half of the 1st century onwards and that they were most widespread in the 2nd century.²²⁵ Jar primarily served for storage, while the form was particularly suitable for transport (fig. 12). They were used as urns from the 2nd century onwards, and from the beginning of the 3rd century square jars slowly disappeared from use.

Impressions on the bases of such jars are fairly common. Several types of base marks and/or impressions exist including circles,

²¹⁴ Czurda-Ruth 1979, 156.

²¹⁵ Plesničar Gec 1983, t. 3: 18; 9: 2,3; 30: 16; Celje – neobjavljena građa.

²¹⁶ Lazar 2003, 163.

²¹⁷ Kolšek 1977, 15.

²¹⁸ Pahič 1969, 74.

²¹⁹ Istenič 2000, 204, 214, 57.

²²⁰ Slabe 1976, 245; Kolšek 1977, 13.

²²¹ Gregl 2007, 279, t. 6: 1,2; 8: 3; Trasporenze 1998, 226, no. 259, 260.

²²² Petru 1972, t. 15: 33; Plesničar-Gec 1972, t. 208: 1; Plesničar-Gec 1972, t. 169: 1; 170: 1.

²²³ Trasporenze 1998, 218, no. 241, 242, 246.

²²⁴ Lazar 2003, 160.

²²⁵ Lazar 2003, 161.

²²⁶ Lazar 2006b, 247, SI70–77.

²²⁷ Lazar 2008, t. 1: 13; 8: 16; u tisku.

²¹² Whitehouse 1997, 172.

²¹³ Cool, Price 1995, 110.

²¹⁴ Czurda-Ruth 1979, 156.

²¹⁵ Plesničar Gec 1983, pl. 3: 18; 9: 2,3; 30: 16; Celje – unpublished material.

²¹⁶ Lazar 2003, 163.

²¹⁷ Kolšek 1977, 15.

²¹⁸ Pahič 1969, 74.

²¹⁹ Istenič 2000, 204, 214, 57.

²²⁰ Slabe 1976, 245; Kolšek 1977, 13.

²²¹ Gregl 2007, 279, pl. 6: 1, 2; 8: 3; Trasporenze 1998, 226, nos. 259, 260.

²²² Petru 1972, pl. 15: 33; Plesničar-Gec 1972, pl. 208: 1; Plesničar-Gec 1972, pl. 169: 1; 170: 1.

²²³ Trasporenze 1998, 218, nos. 241, 242, 246.

²²⁴ Lazar 2003, 160.

²²⁵ Lazar 2003, 161.

2. stoljeća je grob 130 iz Poetovione s vrčem istovjetnog tipa i dekoracije.²²⁸

Veći kvadratični lonac (t. 14: 1) sadrži pet koncentričnih krugova na dnu kombiniranih sa slovima: A u središtu i S u gornjem desnom kutu. U donjem desnom kutu vidljivi su tragovi slijedećeg slova (S ili C?), dva kuta na lijevoj strani su nečitljiva. Najbolja usporedba oznake dna može se naći u Mađarskoj;²²⁹ u grobu iz Solymára pronađeno je dno kvadratične boce (?) ili lonca sa istovjetnim otiskom dna u dekoraciji i slovima - pet koncentričnih krugova sa slovom A u središtu i slovima A i S u gornjim kutovima. Na osnovi vrča iz Bakra moguće je nazrijeti tragove trećeg slova, možda još jednoga S. Četvrti kut nije dobro očuvan ni na jednoj posudi da bi se moglo zaključiti je li postojao otisak četvrtog slova ili ne. Grob iz Solymára datiran je u prvu pol. 2. st.²³⁰

Varia

U ovu smo skupinu uvrstili više proizvoda različitih namjena (posude za piće, kozmetičke i medicinske posude, odnosno pomagala) koji se pojavljuju u manjem broju, odnosno samo po jedan komad.

Među rjeđim oblicima pripada rog, odnosno riton (*rhyton*) s dužim vratom i cjevasto savijenim rubom (t. 15: 1). Pripada obliku Is 73b, a među slovenskom građom lako bismo ga opredijelili kao posebnu inačicu u posljednjoj skupini proizvoda (oblik 10.4.2.).²³¹ Oblik Is 73b pripada jednostavnim izvedbama, a varijanti Is 73a pripadaju predmeti šireg oboda; zašiljeni donji dio oblikovan je poput životinjske glave i obično stoji na niskoj nozi.²³² Taj oblik posuda se prvotno izrađivao od životinjskih rogova, a kasnije su nastale inačice u slonovači, metalu, keramici i staklu.²³³ Na vrhu roga je mali prirodni otvor, koji osoba koja pije zatvori prstom kada je posuda puna. Uporaba rogova za piće dokumentirana je i na freski u Herkulanumu.²³⁴

O uporabi jednostavnijih inačica (10.4.2. – Is 73b) manje znamo; možda su ih upotrebljavali kao sifon ili lijevak (*infundibulum*).²³⁵ U kalup puhana posuda poznata je iz Pompeja.²³⁶ Rogove s ukrasom nataljenih komadića stakla nalazimo u građi muzeja u Adriji²³⁷ i u Emoni, a datirani su u 1. stoljeće. Ima više poznatih posuda bez ukrasa. Najbližu usporedbu nalazimo u grobu 588 iz Emone²³⁸ i u Akvileji;²³⁹ spomenimo još i nalaz iz prve pol. 1.

²²⁸ Istenič 2000, 235.

²²⁹ Barkóczy 1988, 177, no. 421.

²³⁰ Barkóczy 1988, 177.

²³¹ Lazar 2003, 24, 173.

²³² vidi npr. Calvi 1969, Taf. 19: 1; Whitehouse 1997, 118–120.

²³³ Saldern 1976.

²³⁴ Sampaolo 1986, 170, št. 340.

²³⁵ Isings 1957, 91.

²³⁶ Isings 1957, 91.

²³⁷ Bonomi 1994, 199, no. 450.

²³⁸ Plesničar Gec 1972, t. 135: 11.

²³⁹ Mandruzzato, Marcante 2005, 35, no. 330, 331.

squares, rosettes with leafs, and also inscriptions on the base. Vessels with concentric circles are represented in great numbers in the graves of *Emona*.²²⁶ Four jars have two, five or seven concentric circles. Analogies are also known among the unpublished material from the graves at the *Slovenijales* site (gr. 2 with a coin of Vespasian, gr. 21).²²⁷ On the basis of the grave goods, the graves can be dated to the second half of the 1st and the 2nd centuries. Grave 130 from Poetovio with a jar of the same type and decoration is also from the 2nd century.²²⁸

The larger square jar (pl. 14: 1) has five concentric circles on the bottom combined with letters: A in the centre and S in the upper right corner. On the lower right corner are visible traces of another letter (S or C?), while two corners on the left are illegible. The best comparison for the base mark can be found in Hungary;²²⁹ a base of a square bottle (?) or jar was found in a grave from Solymár with an identical base mark in terms of decoration and letters – five concentric circles with the letter A in the centre and the letters S and C in the upper corners. On the basis of the jar from Bakar traces can be perceived of the third letter, perhaps another S. The fourth corner is not well enough preserved on either of the vessels to conclude whether or not the imprint of a fourth letter existed. The grave from Solymár is dated to the first half of the 2nd century.²³⁰

Varia

Several products of varied purpose have been placed in this group (drinking glass, cosmetic and medicinal vessels or implements) that were found in smaller numbers or as a single example.

Less common forms include a drinking horn or *rhyton* with a somewhat elongated neck and a tubular everted rim (pl. 15: 1). It belongs to form Isings 73b, and among the Slovenian material it can be classified as a special variant in the last group of products (form 10.4.2.).²³¹ Form Isings 73b includes simpler versions, while variant Isings 73a consists of products with a wider mouth and a pointed lower section formed in the shape of an animal head that usually stand on a low foot.²³² This form of vessel was first made from animal horns, and variants later appeared in ivory, metal, pottery, and glass.²³³ The end of the horn usually has a small opening that the drinker closes with a finger when the vessel is full. The use of drinking horns has been documented on a fresco from Herculaneum.²³⁴

Less is known about the use of simpler versions (10.4.2 – Isings 73b); perhaps they were used as a siphon or funnel (*infundibulum*).²³⁵ A mould blown vessel of this type is known from Pompeii.²³⁶ A drinking horn with a decoration of marvered chips of glass can be found among the material in the museum in Adria,²³⁷ dated to the 1st century. More undecorated vessels are known. The closest analogies can be found in grave 588 from Emona,²³⁸ at Aquileia,²³⁹ along

²²⁶ Lazar 2006b, 247, S170–77.

²²⁷ Lazar 2008, pl. 1: 13; 8: 16; in press.

²²⁸ Istenič 2000, 235.

²²⁹ Barkóczy 1988, 177, no. 421.

²³⁰ Barkóczy 1988, 177.

²³¹ Lazar 2003, 24, 173.

²³² See e.g. Calvi 1969, pl. 19: 1; Whitehouse 1997, 118–120.

²³³ Saldern 1976.

²³⁴ Sampaolo 1986, 170, no. 340.

²³⁵ Isings 1957, 91.

²³⁶ Isings 1957, 91.

²³⁷ Bonomi 1994, 199, no. 450.

²³⁸ Plesničar Gec 1972, pl. 135: 11.

²³⁹ Mandruzzato, Marcante 2005, 35, nos. 330, 331.



Sl. 12 Cilindrična boca i kvadratne urne | Fig. 12 Cylindrical bottle and two square jars (Inv. br. / Inv. no. 11377, 11345, 11864)

st. iz Kölna²⁴⁰ te primjerke iz Nîmes iz 1. stoljeća.²⁴¹ Bakarskomu rogu gotovo identičan primjerak s malo duljim vratom nalazimo u Hrvatskoj, na zadarskoj nekropoli Relja u grobu 450 te u Argyruntumu.²⁴² Prvi je s obzirom na grobnu cjelinu datiran u drugu pol. 1. st. i u 2. stoljeće, drugi pak s obzirom na usporedbu, u drugu pol. 1. st. U muranskome muzeju čuva se još jedan rog iz Zadra koji je ukrašen s uzdužno postavljenim rebrima a najvjerojatnije je nastao u jednoj od sjevernoitalskih radionica.²⁴³ Kao nalaz iz nekropole datiran je u drugu pol. 1. st. i 2. st. S obzirom na usporedbu, opredjeljujemo bakarski nalaz u drugu pol. 1. st.

Osamljeni nalaz među bakarskim staklom je posebna ampula s odebljanjem u sredini i savijenim donjim dijelom (t. 15: 2). Ni donji ni gornji kraj nisu u cijelosti očuvani, stoga o veličini možemo tek nagađati. Ampule koje su upotrijebljene u medicinske i kozmetičke (ili prehrambene) svrhe, očuvale su se u različitim izvedbama. Vremenski ih je teško odrediti jer je riječ o obliku kod kojeg je važna funkcionalnost, a ne moda, te su istovjetni oblici u uporabi bili kroz duže vrijeme. Možda bismo nalaz iz Volcere lako odredili kao gustomjer, odnosno sifon za kušanje vina, kakvih se iz rimskog doba očuvalo vrlo malo. Govori se o obliku Is 76, gdje autorica spominje dva do tada poznata nalaza iz druge pol. 1. st.²⁴⁴ Od novijih objava poznajemo još primjerke iz Akvileje i Zadra²⁴⁵ za koje autorice pretpostavljaju da su italski proizvodi te oba sifona datiraju u 1. stoljeće.²⁴⁶

Posebno je zanimljiva amforica s ostatkom stakla na vanjskoj strani dna (t. 15: 3), po čemu zaključujemo da je možda bila dio neke veće posude. Donjim dijelom je bila pričvršćena na udubljeno dno, možda lonca, žare ili kakvog drugog oblika veće posude na unutrašnjoj strani. Kakva je bila namjena te kombinacije samo nagađamo; slične staklene nosače poznajemo na kasnoantičkim svjetiljkama,²⁴⁷ gdje su bili namijenjeni držanju stijenja (fitalja). Točnih usporedbi za naš nalaz među objavljenom građom nismo našli te ga nije moguće precizno datirati.

with a find from the first half of the 1st century from Köln²⁴⁰ and examples from Nîmes dated to the 1st century.²⁴¹ Almost identical analogies to the Bakar horn with a somewhat longer neck can be found among Croatian material, from grave 450 at the necropolis of Relja in Zadar and from Argyruntum.²⁴² The first is dated by the grave context to the second half of the 1st century and in the 2nd century, while the second was dated on the basis of comparisons to the second half of the 1st century. Another horn from Zadar, decorated with lengthwise ribs, is in the museum in Murano and was probably made in one of the northern Italian workshops.²⁴³ It is dated like the find from the Zadar necropolis to the second half of the 1st and the 2nd centuries. Similarly, on the basis of comparisons, the find from Bakar can be assigned to the second half of the 1st century.

An isolated find among the Bakar glass is an ampulla with a thickening in the centre and a curved lower section (pl. 15: 2). Neither the lower nor the upper ends have been preserved, hence the dimensions remain unknown. Ampullae that were used for medical and cosmetic (or alimentary) purposes have been preserved in various versions. It is difficult to classify them chronologically, as these were forms where the function and not fashion was important, and identical forms were in use throughout a lengthy period. Perhaps the find from Volcera could be classified as a siphon for trying wines, very few of which have been preserved from the Roman period. This would be form Is 76, where the author mentions only two finds known until then, from the second half of the 1st century.²⁴⁴ More recent publications offer additional examples from Aquileia and Zadar.²⁴⁵ The authors consider them to be Italic products and both siphons are dated to the 1st century.²⁴⁶

A small flask or miniature amphora is quite interesting, with remains of glass on the exterior side of the base (pl. 15: 3), leading to the conclusion that it had once been part of some larger vessel. The lower part was attached to the inner side of the concave base of some larger vessel, such as a jar, urn, or some other form of large vessel. The purpose of such a combination can only be conjectured; similar glass bases are known for Late Roman candelabras,²⁴⁷ where they were used to store wicks. No exact analogies were found for this find among the published material and hence it cannot be dated precisely.

²⁴⁰ Fremersdorf 1958, 56, taf. 130.

²⁴¹ Sternini 1991, 181–182, Pl. 64.

²⁴² Trasparenze 1998, 209, no. 218, 219.

²⁴³ Ravagnan 1994, 236, no. 471.

²⁴⁴ Isings 1957, 93.

²⁴⁵ Mandruzzato, Marcante 2005, 35, no. 329; Ravagnan 1994, 234, no. 470.

²⁴⁶ Mandruzzato, Marcante 2005, 35.

²⁴⁷ Whitehouse 1997, 359, no. 339.

²⁴⁰ Fremersdorf 1958, 56, pl. 130.

²⁴¹ Sternini 1991, 181–182, pl. 64.

²⁴² Trasparenze 1998, 209, nos. 218, 219.

²⁴³ Ravagnan 1994, 236, no. 471.

²⁴⁴ Isings 1957, 93.

²⁴⁵ Mandruzzato, Marcante 2005, 35, no. 329; Ravagnan 1994, 234, no. 470.

²⁴⁶ Mandruzzato, Marcante 2005, 35.

²⁴⁷ Whitehouse 1997, 359, no. 339.

Kozmetičko posuđe

U toj skupini, u kojoj najveći dio čine balzamariji, prvo govorimo o vrčiću s dvije ručke (t. 15: 4), odnosno amforici od obojenog stakla (*aryballos*). Karakteristična posudica od jantarnog stakla s plavim ručkama (sl. 17) proizvod je koji su u grčkom i rimskom svijetu upotrebljavali u kupalištima za pohranu ulja. Prvotno su je povezivali s običajima kupanja muškog dijela populacije, te bi ih nosili privezane, odnosno pričvršćene oko zapešća na sportske priredbe. Poznajemo nekoliko slučajeva kada su osim staklene posude očuvane brončane ručke s omčom.²⁴⁸

Prvi puhani aribaldi izrađeni su od obojenog stakla, imaju malo viši vrat i dvije ručke, koje su obično izrađene od stakla kontrastne boje. Dodatak stakla kontrastne boje na posudi (ručke, rub) još jače naglašava intenzivnost, primjerice kobaltno tamnoplave, jantarne ili tamnozeleno boje samog proizvoda. Proizvodnja tih posudica počela je malo prije sredine 1. stoljeća, a nastale su u više različitih radionica. Pretpostavka o sirijskom ili palestinskom izvoru proizvoda nažalost nije potkrijepljena konkretnim nalazima na terenu.²⁴⁹ N. Sorokina te aribale razdijelila je u više skupina, a nalaz iz Bakra pripadao bi tako skupini I.²⁵⁰ Ti rani proizvodi iz radionica istočnog Sredozemlja rašireni su uglavnom kroz cijelo 1. stoljeće. Ipak, nalazišta nisu ograničena samo na istočni dio rimske države, pojedini nalazi poznati su iz Iraka s Arapskog poluotoka.²⁵¹ U Italiji i zapadnim provincijama takve su posudice rijetke. Iznimka su nalazi na jadranskoj obali koje poznajemo iz Zadra, Nina, Aserije,²⁵² a jedna je bila nađena u grobu u Emoni.²⁵³

E. M. Stern pretpostavlja da su možda aribaldi kao izvozni proizvod bili namijenjeni u prvom redu onim područjima imperija gdje su događanja u velikim javnim kupalištima imala važnu ulogu u javnom životu.²⁵⁴ Stoga broj nalaza na područjima kao što su primjerice Crno more i jadranska obala, koji su imali intenzivne trgovačke veze s istočnim Sredozemljem, ne iznenađuje.

²⁴⁸ Lazar 2003, 169, 8.3.4.; Wiewegh 2003, 59, t. 35: 2.

²⁴⁹ Stern 2001, 44.

²⁵⁰ Sorokina 1987, 40–46.

²⁵¹ Stern 2001, 44.

²⁵² Ravagnan 1994, 43, no. 49; Trasprenze 1998, 132, no. 79–81.

²⁵³ Plesničar Gec 1972, gr. 90, t. 22.

²⁵⁴ Stern 2001, 45.

Vessels for cosmetics and medicinal unguents

This group, which primarily consists of balsamaria, also includes a small two-handled jug (pl. 15: 4), or miniature amphora of coloured glass (*aryballos*). This characteristic small vessel of amber glass with blue handles (fig. 17) is an item that was used in the baths of the Greek and Roman world to store oil. These bath flasks were primarily related to the bathing customs of the male part of the population, who carried them to sports events tied or attached to a wrist. Several examples are known where in addition to the glass vessel, bronze handles with loops have been preserved.²⁴⁸

The first blown aryballoi were made from coloured glass and have a somewhat longer neck and two handles, usually made from a contrasting colour of glass. The addition of glass with a contrasting colour to the vessel (handles, rim) further emphasized the intensive colour of the product, such as cobalt blue, dark green or amber. The production of these vessels began a little before the middle of the 1st century, and they were made in several different workshops. The theory of a Syrian or Palestinian origin unfortunately is not supported by concrete finds in the field.²⁴⁹ N. Sorokina classified these small flasks into several groups, and the find from Bakar would belong to group I.²⁵⁰ These early products from eastern Mediterranean workshops are fairly widespread throughout the entire 1st century. Finds are nonetheless not limited merely to the eastern part of the Roman state, as individual finds are also known from Iraq and the Arabian peninsula.²⁵¹ Such vessels are rare in Italy and the western provinces. The exceptions are sites along the Adriatic coast, where they are known from Zadar, Nin, and Asseria,²⁵² and one example was also found in a grave at Emona.²⁵³

E. M. Stern suggested that perhaps aryballoi were primarily intended as an export product, especially for those regions of the empire where events in large public baths played an important role in public life.²⁵⁴ Hence the number of finds in areas such as the Black Sea and the Adriatic coast, which had intensive trade connections with the eastern Mediterranean, is not surprising.

²⁴⁸ Lazar 2003, 172, 8.3.4; Wiewegh 2003, 59, pl. 35: 2.

²⁴⁹ Stern 2001, 44.

²⁵⁰ Sorokina 1987, 40–46.

²⁵¹ Stern 2001, 44.

²⁵² Ravagnan 1994, 43, no. 49; Trasprenze 1998, 132, nos. 79–81.

²⁵³ Plesničar Gec 1972, gr. 90, pl. 22.

²⁵⁴ Stern 2001, 45.

Pod imenom Merkur-bočice poznajemo posude četverokutnih stijenki s dugim vratom koje su vjerojatno služile za pohranu ulja i mirisa, a dugi je vrat sprečavao prebrzo hlapljenje sadržaja. Stijenka je bila puhana u kalup. Glavna značajka tih posuda su različiti pečati i otisci na dnu, rjeđe i na stijenkama. Najčešće je na dnu ukras palmete, kombiniran sa četiri točke u kutu ili kraticama proizvođača.²⁵⁵ Neke boce na dnu imaju lik boga Merkura i kratice proizvođača (?) u kutu te im je upravo to dalo ime.²⁵⁶ Jednostavniji otisci imaju samo naznačeno kvadratno polje, krugove u kutovima ili pojedinačna slova,²⁵⁷ a pojavljuju se i lik Venere.²⁵⁸ Različite varijante ovih posudica pokazuju da su nastajale u mnogim radionicama. Iznimno se pojavljuju i šesterokutne i osmerokutne posude koje su u većem broju znane ponajprije u Istri i Dalmaciji. Vjerojatno je riječ o lokalnim varijantama, pa su zato dobile ime pseudo Merkur-bočice.²⁵⁹

Nalaz iz Bakra pripada klasičnoj varijanti sa četverokutnim stijenkama od dekoliranog stakla (t. 16: 1) s otiskom rozete na dnu. Druga boca je osmerokutna (t. 16: 2), od prirodno obojenog stakla i na dnu ima otisak nepravilno raspoređenih šest točaka. Potonjoj nalazimo usporedbu među zadarskom građom.²⁶⁰

Velik broj kvadratnih bočica na terenu sjeverne Italije, grupiranih prvenstveno uz rijeku Pad, kojom se odvijala trgovina padskog područja s teritorijem Istočnih Alpa i Panonije navodi na zaključak da je negdje na tom području postojala radionica takovrsnih proizvoda. Većina nalaza datirana je u 2. i 3. stoljeće.²⁶¹

Mali okrugli lončići sa široko razgrnutim obodom i svinutim rubom (minijaturene žare) pretežno su izrađeni od prirodno obojenog stakla. Vjerojatno su služili za pohranu različitih masti i drugih pripravaka upotrebljivanih u kozmetici i medicini. Međusobno se razlikuju u detaljima. Većinom imaju snažno razgrnut obod koji je zataljen i odebljan ili cjevasto savijen. Uobičajeno je da su stijenke kuglaste, blago bikonične s istaknutim ili malo jače ovalno oblikovanim ramenom.

Lončići ne pripadaju vrlo čestim nalazima, a svejedno ih poznajemo s nalazišta u Britaniji, Njemačkoj i Mađarskoj. Najstariji nalazi datirani su u klaudivjevsko vrijeme, a poznati su iz Hofheima – oblik 19.²⁶² Najčešće se pojavljuju u kontekstima s kraja 1. stoljeća i u 2. stoljeću, a nalazimo ih u grobovima iz 3. stoljeća.²⁶³ Nalazi iz Mađarske većinom su datirani na kraj 1. stoljeća i u 2. stoljeće.²⁶⁴ Rützi pak nalaze iz Augsta datira u rasponu od klaudivjevskog vremena do 4. stoljeća.²⁶⁵

Nekoliko ranih primjeraka ovih posudica poznajemo iz Zadra, a izrađeni su od obojenog i višebojnog stakla i datirani su u 1. stoljeće.²⁶⁶ Poredbene primjerke iz Slovenije poznajemo iz groba 14 iz Formina, koji je datiran na kraj 1., odnosno početak 2. stoljeća, a grob 338 u 2. stoljeće.²⁶⁷ Grobovi 238 i 778 na

The term Mercury flask is used for small vessels with square body and a long neck that were probably used to store oils and perfumes, with the long neck preventing the contents from evaporating too quickly. The walls were blown into a mould. The main characteristics of these vessels are various stamps and impressions on the base, and more rarely also on the walls. The most frequent decoration on the base is a palmette, combined with four points in the corners or abbreviations of the name of the manufacturer.²⁵⁵ Some flasks have an image of the god Mercury on the base along with the manufacturer's initials (?) in the corners, and this was what gave the flasks their name.²⁵⁶ More simple impressions merely have a square field, circles in the corners, or individual letters.²⁵⁷ The image of Venus can also be depicted.²⁵⁸ The diverse variants of these vessels indicate that they were produced in many workshops. Six-sided and eight-sided vessels also occasionally appear, known in greater numbers primarily from Istria and Dalmatia. These were probably local variants, and hence they have been given the name pseudo-Mercury flasks.²⁵⁹

One find from Bakar belongs to the classical variant with square body, made from decoloured glass (pl. 16: 1) with a rosette mark on the base. The other flask is octagonal (pl. 16: 2), made of naturally coloured glass, with six irregularly arranged points on the base. Analogies can be found for the latter among the material from Zadar.²⁶⁰

The exceptional quantity of square flasks in the region of northern Italy, grouped primarily along the waterways of the Po valley, the trade routes of the Po region with the lands of the Eastern Alps and Pannonia, leads to the conclusion that a workshop manufacturing such products probably existed somewhere in this region. Most of the finds are dated to the 2nd and 3rd centuries.²⁶¹

Small globular jars with widely splayed and tubular rims (miniature jars) were mostly made of naturally coloured glass. They probably served as storage for various ointments and other preparations used as cosmetics and in medicine. They differ only in details. Most have a strongly everted rim that is fire-rounded, thickened, or tubularly bent. The walls are usually globular in form, slightly biconical with an emphasized shoulder, or somewhat more oval shaped.

Small jars are not very common finds, but they are still known from sites in Great Britain, Germany, and Hungary. The earliest finds, dated to the Claudian period, are known from Hofheim – form 19.²⁶² They most often appear in contexts from the end of the 1st and in the 2nd century, and can also be found in graves of the 3rd century.²⁶³ Finds from Hungary are mostly dated to the end of the 1st century and the 2nd century.²⁶⁴ Rützi dates the finds from Augst in a span from the Claudian period to the 4th century.²⁶⁵

Several early examples of these vessels are known from Zadar, made of coloured and multicoloured glass and dated to the 1st century.²⁶⁶ Comparisons from Slovenia are known from grave 14 at Formin, which is dated to the end of the 1st or beginning of the 2nd century, and from grave 338, dated to the 2nd century.²⁶⁷ Graves 238 and

²⁵⁵ Facchini 1995, Tav. B, D.

²⁵⁶ Facchini 1995, Tav. C: 28; E: 1, 3.

²⁵⁷ Facchini 1995, Tav. A.

²⁵⁸ Sablerolles 2006, 24.

²⁵⁹ Fadić 1987, 113; Kirigin 1980, 63; Lazar 2006c, 280, CRO 25–35.

²⁶⁰ Fadić 2005, 206, fig. 1.13.

²⁶¹ Facchini 1995, 170–171.

²⁶² Ritterling 1912, 376.

²⁶³ Cool, Price 1995, 116.

²⁶⁴ Barkóczy 1988, 205.

²⁶⁵ Rützi 1991, 51.

²⁶⁶ Trasparenze 1998, 124, no. 63, 64.

²⁶⁷ Mikl-Curk 1975, Y 182; Kujundžić 1982, 50.

²⁵⁵ Facchini 1995, pl. B, D.

²⁵⁶ Facchini 1995, pl. C: 28; E: 1, 3.

²⁵⁷ Facchini 1995, pl. A.

²⁵⁸ Sablerolles 2006, 24.

²⁵⁹ Fadić 1987, 113; Kirigin 1980, 63; Lazar 2006c, 280, CRO 25–35.

²⁶⁰ Fadić 2005, 206, fig. 1.13.

²⁶¹ Facchini 1995, 170–171.

²⁶² Ritterling 1912, 376.

²⁶³ Cool, Price 1995, 116.

²⁶⁴ Barkóczy 1988, 205.

²⁶⁵ Rützi 1991, 51.

²⁶⁶ Trasparenze 1998, 124, nos. 63, 64.

²⁶⁷ Mikl-Curk 1975, Y 182; Kujundžić 1982, 50.

zapadnoj petovijskoj nekropoli su iz prve pol. 2. st.²⁶⁸ Z. Buljević taj oblik naziva oliformni balzamariji ili teglice (3i)²⁶⁹ i smatra da su u Salonu pristizali kao import iz sjevernoitalske radionice od početka flavijevskog doba do kraja 2. stoljeća. Posudice iz Bakra imaju cjevasto savijen (t. 16: 3–5) i malo deblji rub (t. 16: 6) te ih s obzirom na analogije, možemo datirati na kraj 1. stoljeća i u 2. stoljeće.

Balzamariji

Kao posljednju skupinu izdvajamo balzamarije koji su, kao obično, i u bakarskoj zbirci zastupljeni u najvećem broju i s različitim varijantama oblika (sl. 13–16). Balzamariji pripadaju najstarijim oblicima staklenih posuda. Još u Egiptu i Mezopotamiji su ih izrađivali tehnikom nabiranja stakla oko jezgre. Veličina posudica govori o dragocjenom i ne svima dostupnom sadržaju koji je u njih pohranjivan. Poradi jednostavnog oblika to su bili i prvi proizvodi koji su nastali tehnikom slobodnog puhanja stakla. Datiramo ih u posljednju četvrtinu 1. st. pr. Kr.²⁷⁰ Još je u augustovsko doba proizvodnja balzamarija u zapadnom i istočnom dijelu imperija dosegla vrhunac. Ubrzo potom rasprostranili su se dekorativni, u kalup puhani balzamariji.²⁷¹ Služili su za pohranu i transport kozmetičkih tvari različitih mirisa, ulja, boja, medicinskih pripravaka i osušenih biljaka. Dug i uzak vrat sprečavao je hlapljenje tvari iz posudice, a za doziranje sadržaja pomagali su dugi stakleni štapići ili različite medicinske žličice.

Sadržaj balzamarija rijetko je očuvan. S obzirom na oblik, ne možemo sa sigurnošću tvrditi je li određeni tip balzamarija bio povezan s točno određenim sadržajem. Zatvarani su čepom, zatvaračem od organskih materijala. Na nekim bočicama prepoznajemo na dnu otiske ili pečate u geometrijskim i figuralnim izvedbama, a također i u kombinacijama s različitim imenima i kraticama koje su vjerojatno povezane s izradom i pripremom mirisnih tvari, ulja ili masti. Stoga su se neke staklarske radionice razvile u neposrednoj blizini proizvodnih centara dragocjenih mirisnih supstancija, primjerice u Izraelu i Kampaniji.²⁷²

Balzamariji su izrađivani od obojenog, višebojnog i prirodnog modrozelenkastog stakla. Proizvodi od višebojnog ili obojenog neprozirnog stakla pripadaju luksuznim primjercima. Obojeno staklo je u prvoj pol. 1. st. bilo posebice omiljeno. Treba naglasiti da su neke tvari koje su balzamariji čuvali bile osjetljive na svjetlost; zato su ih morali pohranjivati u posude od neprozirnog ili tamnije obojenog stakla. Pojedini su oblici tih posudica bili unaprijed punjeni sadržajem i potom zatvarani grijanjem stakla; takvi su balzamariji u obliku ptica, češera i sl., koji imaju uvijek odlomljen vrh. Ti oblici bili su popularniji i rašireniji u zapadnom dijelu imperija nego kod staklara u istočnom Sredozemlju.²⁷³

Raspon oblika slobodno puhanih balzamarija iznimno je širok. Uvijek je potrebno naglasiti da se zbog prirode tehnike puhanja, svaka i najmanja razlika u obliku, odnosno detalju izrade ne može – niti je to smisleno – opredijeliti kao novi oblik. Te su male potankosti dobrano ovisne o više ili manje iskusnom staklaru ili njegovu pomoćniku (i duže ili kraće tradicije pojedine radionice),

778 at the western necropolis of Poetovio are from the first half of the 2nd century.²⁶⁸ Z. Buljević calls this form olla-shaped balsamaria or little pots (form 3i),²⁶⁹ and considers that they arrived in Salona as imports from northern Italic workshops from the beginning of the Flavian period to the end of the 2nd century. The vessels from Bakar have tubularly rolled (pl. 16: 3-5) and somewhat thickened rims (pl. 16: 6), and they can be dated to the end of the 1st century and the 2nd century on the basis of analogies.

Balsamaria

The last group to be discussed consists of balsamaria, which are as usual represented with the greatest numbers and diverse variations in form (figs. 13–16). Balsamaria are among the earliest forms of glass vessels. In ancient Egypt and Mesopotamia they were made with a technique of core forming. The size of the miniature vessels speaks of the valuable contents, not accessible to all, that were stored in them. The simple form meant that these were also the first products to be created using the free-blowing glass technique. They can be dated to the last quarter of the 1st century BC.²⁷⁰ In the Augustan period, the production of balsamaria reached its peak in the western and eastern parts of the empire. Shortly afterwards decorative mould-blown balsamaria spread widely.²⁷¹ They served for the storage and transport of cosmetic substances, various scents, oils, paints, medicinal preparations, and dried herbs. The long and narrow neck prevented evaporation from the vessel, and dosages were removed with long glass rods or various medicinal spoons and implements.

The contents of balsamaria have rarely been preserved. In terms of form, it cannot be established with certainty if a given type of balsamarium was connected with a specific content. They were closed with a stopper made from organic material. Some flasks have figural and geometric impressions or stamps on the bottom, also in combination with various names and abbreviations that were probably connected to the manufacture and preparation of fragrant substances, oils, or ointments. Hence some glass workshops developed in the immediate vicinity of production centers of precious fragrant substances, such as in Israel and Campagna.²⁷²

Balsamaria were made of coloured, multicoloured, and natural blue-green glass. Products of multicoloured or coloured opaque glass can be classified as luxurious examples, and in the first half of the 1st century, coloured glass was particularly popular. It should also be noted that certain substances that were kept in balsamaria were sensitive to sunlight, and hence they had to be stored in vessels of opaque or darkly coloured glass. Individual forms of these vessels were filled with the contents first and then closed by heating the glass; examples are balsamaria in the form of birds, pinecones, etc., which always have the top broken off. Such forms were more popular and widespread in the western part of the empire than among the glass workshops of the eastern Mediterranean.²⁷³

The range of forms of free-blown balsamaria is extraordinarily broad. Nonetheless it is necessary to emphasize that because of the nature of the free-blowing technique each minor difference in form or feature of workmanship should not and cannot be defined as a new form. To a great extent these are small details depending on the amount of experience of the glassworker or his apprentice (as well as the lengthy or brief tradition of individual workshops), who was

²⁶⁸ Istenič 2000, 87, 251.

²⁶⁹ Buljević 2004, 85.

²⁷⁰ De Tommaso 1990, 19.

²⁷¹ De Tommaso 1990, 20.

²⁷² Stern 2001, 43.

²⁷³ Stern 2001, 43.

²⁶⁸ Istenič 2000, 87, 251.

²⁶⁹ Type 3i; 2004, 85.

²⁷⁰ De Tommaso 1990, 19.

²⁷¹ De Tommaso 1990, 20.

²⁷² Stern 2001, 43.

²⁷³ Stern 2001, 43.



Sl. 13 Balzamariji od obojenog stakla | Fig. 13 Balsamaria made of coloured glass
(Inv. br. / Inv. no. 11095, 11082, 11335, 11334, 11333, 11332)

koji se obučavao u majstorstvu puhanja najprije u izradi jednostavnijih oblika. Puhanje obične kuglaste boce iziskuje malo obrade oruđem; okrugli, cjevasti ili kruškasti oblik staklar lako izrađuje samo puhanjem, bez dodatne dorade.²⁷⁴

Različite tipologije ovih posudica dovele su neke autore do mnogobrojnih varijanti. De Tommaso²⁷⁵ je pripremio tipologiju talijanskih nalaza pomoću numeriranja. Mjerne razlike i detalji rezultirali su izvanrednim brojem oblika. Posebnu tipologiju balzamarija iz Salone pripremila je Z. Buljević, koja detaljno dijeli bočice u grupe i podgrupe.²⁷⁶

U podjeli bakarskih balzamarija uzeli smo u obzir samo one posude koje su potpuno ili dovoljno sačuvane za podjelu na tipove. Uglavnom smo slijedili podjelu materijala na osnovi šire tipologije C. Isings i materijala iz Slovenije,²⁷⁷ ali smo uključili i podjelu Z. Buljević, jer je riječ o materijalu jadranskog područja.²⁷⁸

Cjevasti balzamariji imaju usko tijelo, koje je pokatkad u sredini naglašeno profilacijom i donji dio tijela je zaokružen (8.6.1.–

trained in the craft secrets of blowing glass first with the production of simple forms. Blowing an ordinary globular bottle requires only a little working with tools; circular, tubular, or pear-shaped forms can be made by a glassworker merely by blowing and without any additional working.²⁷⁴

The diverse typologies of these vessels have led some authors to suggest numerous variants. De Tommaso prepared a typology of the Italian finds by using a numbering system.²⁷⁵ Differences in measurement and details led to an exceptional number of forms. A separate typology of the balsamaria from Salona was prepared by Z. Buljević, who divided these flasks into groups and sub-groups in great detail.²⁷⁶

In the classification of the balsamaria from Bakar, only those vessels were considered that were completely or sufficiently preserved for assignment into types. In general the material was assigned according to the somewhat broader typologies of C. Isings and the Slovenian glass material,²⁷⁷ but we also took into account the typology of Buljević, as this directly concerned material from the Adriatic region.²⁷⁸

²⁷⁴ Stern 1994, 84.

²⁷⁵ De Tommaso 1990.

²⁷⁶ Buljević 1999; 2000, 465; 2004.

²⁷⁷ Isings 1957; Lazar 2003.

²⁷⁸ Buljević 1999; 2000, 465; 2004.

²⁷⁴ Stern 1994, 84.

²⁷⁵ De Tommaso 1990.

²⁷⁶ Buljević 1999; 2000, 465; 2004.

²⁷⁷ Isings 1957; Lazar 2003.

²⁷⁸ Buljević 1999; 2000, 465; 2004.

3.).²⁷⁹ Dno je obično ravno ili blago zaokruženo, rub je izvučen prema van. Balzamariji s glatkim tijelom najraniji su među cjevastim balzamarijama i poznati su već od flavijevskog i trajanovskog razdoblja te u 2. stoljeću.²⁸⁰ Balzamariji s profilacijom na tijelu upotrebljavani su duže vrijeme; potječu već iz 2. i 3. stoljeća, što je posvjedočeno u grobovima Poetovione.²⁸¹ U datiranim grobnim cjelinama balzamariji oblika 8.6.2. poznati su u Ticinu između 20. i 50. god. po Kr.²⁸² Oblik se tijekom stoljeća razvijao od manjih varijanti, gdje je odnos tijelo i vrat 1:1, sve do većih, kojima je vrat dvostruko dulji od tijela.²⁸³ Upotreba ovog oblika bila je najveća u drugoj polovini 1. stoljeća i potrajala je još u prvim desetljećima 2. stoljeća.²⁸⁴ U Sloveniji je taj oblik balzamarija bio vrlo raširen²⁸⁵ i sudeći prema grobnim nalazima, upotrebljavan je u cijelom 2. stoljeću.²⁸⁶ Cjevasti balzamariji iz Bakra srodni su grupi balzamarija iz Salone, za koje Z. Buljević smatra da su italski import iz sredine 1. i početka 2. stoljeća (3k3–5).²⁸⁷

Samo s pojedinim primjercima zastupani su balzamariji oblika 8.6.4. i 8.6.5.²⁸⁸ Prvi, ovalni balzamariji, prema analogijama datirani su na kraj 1. stoljeća i u 2. stoljeće. Balzamariji s manjim, trokutastim tijelom, koji su zastupani s nekoliko primjeraka, također su bili rašireni u drugoj pol. 1. st. i u 2. st.²⁸⁹ Ta je grupa balzamarija manjkavo izrađena, obodi su nejednakomjerni, dno je nepravilno i stoga posudice vise na stranu. Mogli bismo pretpostaviti da su to proizvodi nekih lokalnih radionica u blizini, vjerojatno na samoj jadranskoj obali.

Balzamariji s trokutasto oblikovanim tijelom (t. 17: 9–11) među građom iz Bakra zastupljeni su u većem broju.²⁹⁰ Vrat i tijelo često su odvojeni uvlakom, odnosno profilacijom, koja naglašava prijelaz u vrat. Prema veličini i zapremini tijela prilično premašuju prethodnu skupinu. U Ticinu su ti oblici balzamarija datirani od druge pol. 1. do prve pol. 2. st.²⁹¹ De Tommaso ih opredjeljuje kao tip 43 i 46 te datira u vrijeme flavijevaca do antonina.²⁹² Nalazi iz Slovenije u Poetovionu potvrđuju upotrebu tog oblika u istom razdoblju te još na početku 3. stoljeća.²⁹³ U Saloni (oblik 3l) datirani su od sredine 1. do sredine 2. stoljeća,²⁹⁴ u grobovima iz Medulina pak u 2. i 3. stoljeće.²⁹⁵

Oblik 8.6.9.²⁹⁶ obuhvaća balzamarije malo većih dimenzija (sl. 15 lijevo); tijelo je blago lukovičasto i pokadkad uvlakom odijeljeno od vrata (t. 18: 1–3). Spomenimo analogije iz Slovenije (Ptuj),²⁹⁷ datirane na kraj 1. stoljeća i u prvu pol. 2. st. S hrvatskih nalazišta poznajemo, među inim, analogije u Istri – nekropola

Tubular balsamaria have a narrow body, sometimes emphasized in the centre with a constriction, and the lower part of the body is rounded (8.6.1.–3.).²⁷⁹ The base is usually flat or gently rounded, and the rim is everted. Balsamaria with a smooth body are the earliest of the tubular balsamaria and are known as early as from the Flavian to Trajanic periods and in the 2nd century.²⁸⁰ Balsamaria with a constriction on the body were in use throughout a long time, and they can be found in 2nd and 3rd century contexts, as is indicated by the grave units from Poetovio.²⁸¹ The first appearance of balsamaria of form 8.6.2. in a dated context is known from Ticino, in the period between AD 20 and 50.²⁸² Throughout the course of the century, the form developed from small variants, where the proportion of body to neck was 1:1, to larger vessels where the neck was twice as long as the body.²⁸³ The use of this form was most widespread in the second half of the 1st century, and continued into the first decades of the 2nd century.²⁸⁴ This form of balsamaria was the most numerous at Slovenian sites,²⁸⁵ and the grave finds, indicate that it was still in use throughout the entire 2nd century.²⁸⁶ The tubular balsamaria from Bakar are related to the group of balsamaria from Salona, considered by Z. Buljević to be Italic imports from the middle of the 1st century and the beginning of the 2nd century (types 3k3–5).²⁸⁷

Balsamaria of forms 8.6.4 and 8.6.5 are represented only by a few examples.²⁸⁸ The first, balsamaria with an oval body, can be dated through analogies to the end of the 1st century and in the 2nd century. Balsamaria with a small triangular body, represented by several examples, were also widespread in the second half of the 1st century and in the 2nd century.²⁸⁹ This group of balsamaria is very poorly made, the rims are quite uneven, the base is irregular, and hence the vessels lean to the side. It can be hypothesized that these were the products of some local workshops in the vicinity, probably on the Adriatic coast.

Balsamaria with a conical body (pl. 17: 9–11) are represented in large numbers among the material from Bakar.²⁹⁰ The neck and body are often separated by a constriction or profile emphasizing the transition to the neck. In terms of size and volume, this type is considerably larger than the previous group. At Ticino this form of balsamaria is dated from the second half of the 1st to the first half of the 2nd centuries.²⁹¹ De Tommaso classified them as types 43 and 46 and placed them in the Flavian to Antonine periods.²⁹² Finds from Poetovio in Slovenia confirm the use of this form in the same chronological period, and even at the beginning of the 3rd century.²⁹³ At Salona (form 3l) they are dated from the middle of the 1st to the middle of the 2nd centuries,²⁹⁴ and in graves from Medulin to the 2nd and 3rd centuries.²⁹⁵

²⁷⁹ Lazar 2003, 8.6.1.–3.

²⁸⁰ De Tommaso 1990, 85.

²⁸¹ Istenič 2000, 82, 83, 85, 93.

²⁸² Biaggio Simona 1991, 144.

²⁸³ Biaggio Simona 1991, 141, 111.6.

²⁸⁴ Biaggio Simona 1991, 144.

²⁸⁵ Lazar 2003, 177.

²⁸⁶ Lazar 2003, 195.

²⁸⁷ Buljević 2004, 87, 3k3–5.

²⁸⁸ Lazar 2003, 181.

²⁸⁹ Lazar 2003, 181, 194.

²⁹⁰ Lazar 2003, 182, 8.6.6.

²⁹¹ Biaggio Simona 1990, 132–135.

²⁹² De Tommaso 1990, 66, 69.

²⁹³ Istenič 2000, 14, 54, 116, 157.

²⁹⁴ Buljević 2004, 89.

²⁹⁵ Girardi Jurkić, Džin 2003, 140, br. 114–116.

²⁹⁶ Lazar 2003, 195.

²⁹⁷ Istenič 2000, 35, 206.

²⁷⁹ Lazar 2003, 8.6.1.–3.

²⁸⁰ De Tommaso 1990, 85.

²⁸¹ Istenič 2000, 82, 83, 85, 93.

²⁸² Biaggio Simona 1991, 144.

²⁸³ Biaggio Simona 1991, 141, 111.6.

²⁸⁴ Biaggio Simona 1991, 144.

²⁸⁵ Lazar 2003, 177.

²⁸⁶ Lazar 2003, 195.

²⁸⁷ Buljević 2004, 87, 3k3–5.

²⁸⁸ Lazar 2003, 181.

²⁸⁹ Lazar 2003, 181, 194.

²⁹⁰ Lazar 2003, 182, 8.6.6.

²⁹¹ Biaggio Simona 1990, 132–135.

²⁹² De Tommaso 1990, 66, 69.

²⁹³ Istenič 2000, 14, 54, 116, 157.

²⁹⁴ Buljević 2004, 89.

²⁹⁵ Girardi Jurkić, Džin 2003, 140, nos. 114–116.



Sl. 14 Posuđe od obojenog stakla iz nekropole Bakar | Fig. 14 Vessels made of coloured glass from Bakar

Medulin-Burle²⁹⁸ i u Argyruntumu,²⁹⁹ gdje su datirani od 2. do 3. stoljeća. Nalazi iz Zadra datirani su pak na kraj 1. stoljeća i u 2. stoljeće.³⁰⁰

Oblici sa spljoštenim³⁰¹ tijelom nisu vrlo rasprostranjeni, a dovoljno su značajni za vremensko određivanje. Rašireni su u sjevernoj Italiji, Trieru i na istoku, a De Tommaso ih opredjeljuje kao tip 49 i datira u drugu pol. 2. st.³⁰² U grobnim cjelinama u Poetovionu su najčešći iz 2. stoljeća i u uporabi su bili još u 3. stoljeću.³⁰³ Kod tih su proizvoda često na dnu otisnuti pečati, koji su vjerojatno u vezi s proizvođačima kozmetičkih tvari ili čak s pojedinim radionicama koje su izrađivale proizvode za posebne naručioce.³⁰⁴ Skupina malih balzamarija sa spljoštenim trokutastim tijelom iz Bakra (t. 18: 4–6) izrađena je od manje kvalitetnog stakla, s nejednakomjerno oblikovanim obodom ili dnom; možda je riječ o proizvodima lokalnih radionica. Analogije nalazimo u Saloni, Puli, Naroni i Zadru.³⁰⁵

Form 8.6.9.²⁹⁶ consists of balsamaria of somewhat greater dimensions (fig. 15 – left), whose body somewhat bulbous and is sometimes separated from the neck with a constriction (pl. 18: 100150–3). Analogies can be noted from Slovenia (Ptuj),²⁹⁷ dated to the end of the 1st century and in the first half of the 2nd century. From Croatian sites, comparisons are known from Istria at the necropolis of Medulin-Burle,²⁹⁸ and from Argyruntum,²⁹⁹ where they were dated from the 2nd to 3rd centuries. The finds from Zadar, however, were dated to the end of the 1st century and in the second century.³⁰⁰

Forms with a flattened body³⁰¹ are not very widespread, but are sufficiently characteristic for chronological determination. They are known from northern Italy, Trier, and the East, and De Tommaso classified them as type 49 and assigned them to the second half of the 2nd century.³⁰² They were most common in the grave units at Poetovio in the 2nd century, and continued in use in the 3rd century.³⁰³ Special stamps were often impressed on the base of these products, which were probably related to the manufacturers of cosmetic

²⁹⁸ Girardi Jurkić, Džin 2003, 136, br. 93, 94, 99.

²⁹⁹ Fadić 1997, 22.

³⁰⁰ Ravagnan 1994, 70, br. 114, 115.

³⁰¹ Lazar 2003, 187, 8.6.10.; 8.6.11.

³⁰² De Tommaso 1991, 71.

³⁰³ Kujundžić 1982, 13; Istenič 2000, 128, 180.

³⁰⁴ Fropa 1971, 38; Pasqualucci 1998, 115.

³⁰⁵ Buljević 2004, 91, br. 220, 227; Girardi Jurkić, Džin 2003, 120, br. 32; Buljević 2003, 112, t. 1:18; Trasprenze 1998, 104, br. 29.

²⁹⁶ Lazar 2003, 195.

²⁹⁷ Istenič 2000, 35, 206.

²⁹⁸ Girardi Jurkić, Džin 2003, 136, nos. 93, 94, 99.

²⁹⁹ Fadić 1997, 22.

³⁰⁰ Ravagnan 1994, 70, nos. 114, 115.

³⁰¹ Lazar 2003, 187, 8.6.10; 8.6.11.

³⁰² De Tommaso 1991, 71.

³⁰³ Kujundžić 1982, 13; Istenič 2000, 128, 180.



Sl. 15 Balzamariji | Fig. 15 Balsamaria (Inv. br. / Inv. no. 11051, 11053, 11047, 11044, 11063)

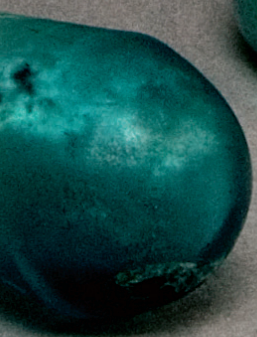



Sl. 16 Vretenasti i spljošteni balsamariji | Fig. 16 Spindle-shaped balsarium and balsamaria with flattened body
(Inv. br. / Inv. no. 11339, 11025, 11330)

među ostalim iz Murse i Narone.³¹⁹ Rani proizvodi imaju kratak vrat s izvučenim obodom i odrezanim rubom. Vjerojatno je riječ o akvilejskom importu. U grobovima se pojavljuju još do prve pol. 2. st. Nalazimo ih primjerice u petovijonskim grobovima iz razdoblja od 1. stoljeća do prve pol. 2. st.³²⁰ U Hrvatskoj im nalazimo usporedbe među građom iz Salone (oblik 3f), gdje su datirani u prvu pol. 1. st., te iz Narone i Zadra.³²¹ Potonji pripadaju 1. stoljeću. Proizvodi većih dimenzija s dugim vratom i udubljenim dnom su mlađi i rašireni su u 2. i 3. stoljeću, iznimno i kasnije, primjerice u grobu 499 iz Poetovione.³²²

Piriformni balsamariji su italski proizvod, koji je stigao na jadransku obalu preko Akvileje (t. 20: 2–6). Rašireni su od kraja 1. stoljeća pr. Kr. do prve pol. 1. st. Izrađivani su u italskim radionicama; ponajčešće su od prozirnog obojenog stakla plave, jantarne ili ljubičaste boje. Poznajemo također višebojne proizvode, među inima iz Zadra,³²³ koji su datirani u prvu pol. 1. st. Neki proizvodi su po stijenkama ukrašeni plitkim vodoravnim linijama.³²⁴ Spomenimo da među građom nalazimo minijaturne izvedbe tog oblika, a jedna takva je očuvana iz Bakra (t. 20: 5). S hrvatskih nalazišta, među ostalima poznajemo analogije u Saloni (oblik 3h)³²⁵ iz prve pol. 1. st. i u Zadru.³²⁶

was reflected in the production and distribution of glass balsamaria or their contents cannot at present be explained.³¹⁶ Balsamaria with the mark PATRIMONI have further been discovered in Croatia at Zadar and Argyruntum,³¹⁷ and are dated to the 2nd century.

Globular balsamaria (pl. 19) were widespread throughout all of Italy (form Is 6), and they are very numerous in Ticino and the western provinces. They were produced from as early as the Augustan period onwards and many were blown from coloured glass (8.6.13).³¹⁸ High quality products made from coloured glass are known from Mursa and Narona, among other places.³¹⁹ Early examples have a short neck and out-turned and cut-off rim. They were probably imported from Aquileia. They appear in graves up to the first half of the 2nd century. They can be found, for example, in graves at Poetovio from the 1st century to the first half of the 2nd century.³²⁰ Analogies can be found in Croatia among material from Salona (form 3f), where they are dated to the first half of the 1st century, Narona, and Zadar.³²¹ The latter are dated to the 1st century. Examples of larger dimensions with a long neck and a concave base are later and were widespread in the 2nd and 3rd centuries, and exceptionally also later, such as in grave 499 from Poetovio.³²²

Pear-shaped balsamaria are Italic products that arrived on the eastern Adriatic coast via Aquileia (pl. 20: 2–6). They were widespread from

³¹⁹ Trasprenze 1998, 106, br. 31, 34.

³²⁰ Istenič 2000, 108.

³²¹ Buljević 2004, 85; Buljević 2003, t. 5: 57, 58; Ravagnan 1994, 81, br. 144, 146, 149, 150.

³²² Istenič 2000, 163.

³²³ Ravagnan 1994, 66, br. 104, 105.

³²⁴ Ravagnan 1994, 62, br. 90, 91.

³²⁵ Buljević 2004, 85.

³²⁶ Ravagnan 1994, 68, br. 108.

³¹⁶ Price 2006, 286.

³¹⁷ Trasprenze 1998, no. 39; Fadić 1997, no. 111.

³¹⁸ Lazar 2003, 196.

³¹⁹ Trasprenze 1998, 106, nos. 31, 34.

³²⁰ Istenič 2000, 108.

³²¹ Buljević 2004, 85; Buljević 2003, pl. 5: 57, 58; Ravagnan 1994, 81, nos. 144, 146, 149, 150.

³²² Istenič 2000, 163.

Balzarariji sa zvonolikim tijelom zastupljeni su samo s jednim primjerkom (8.6.17.),³²⁷ a najveći broj usporedbi nalazi se u Hrvatskoj. Srodan oblik balzararija je obradio Gluščević, koji pretpostavlja da je riječ o proizvodu radionica u Zadru, te je izvan Hrvatske poznato malo njihovih nalaza.³²⁸ Nove objave, doduše šire krug tih proizvoda, no većinom ih nalazimo još i sada, u širem zaleđu jadranskog područja i u Italiji. S obzirom na grobne nalaze iz Dalmacije, datiramo ih u 2. i 3. stoljeće.³²⁹ Istodobnu dataciju potvrđuju grobovi iz Istre – Medulina.³³⁰

Balzarariji s naborima na stijenkama (t. 21: 2) nisu česti oblici (Lazar 2003, 8.6.18.),³³¹ a izrađivani su u više inačica. Razlikuju se po obliku stijenki, dužini vrata, broju udubljena itd. Usporedbe im nalazimo u Akvileji i Dalmaciji,³³² Augstu³³³ i u Mađarskoj.³³⁴ Nalaze iz Dalmacije datira Fadić u 3. i čak u 4. stoljeće,³³⁵ balzararij iz Medulina u Istri datiran je u 2 – 3. stoljeće,³³⁶ mađarske bočice pak uglavnom izviru iz 2. stoljeća.³³⁷ Nalazi iz grobnih cjelina u Sloveniji pripadaju 2. stoljeću.³³⁸ Balzararij iz Bakra ima kratak i širok vrat koji izravno prelazi u cjevast rub. Datiran je u prijelaz 2. u 3. stoljeće.

Balzararij s vretenastim stijenkama (sl. 16 lijevo) osamljeni je primjerak među nalazima iz Bakra (t. 21: 3). Veliki broj usporedbi nije pronađen, a najbliže su vezane za Akvileju³³⁹ i hrvatski prostor. Gotovo identičan čuva se u zbirci zadarskog muzeja³⁴⁰ i datiran je u 2. – 3. stoljeće. Malo drukčija je izvedba vretenastog balzararija iz Salone datiranog u 3. stoljeće i pripisanog zapadnim radionicama.³⁴¹ Bočica iz Bakra bi s obzirom na široki obod, cjevasto savijen rub i blago udubljeno dno, pripadala u 2. – 3. stoljeće.

the end of the 1st century BC to the first half of the 1st century AD. They were manufactured in Italic workshops to a great extent from transparent blue, amber or purple glass. Multicoloured products are also known, including examples from Zadar,³²³ which are dated to the first half of the 1st century. Some examples were decorated with shallow horizontal lines on the walls.³²⁴ Miniature versions of this form can be found among the material, and one such example is preserved from Bakar (pl. 20: 5). From other Croatian sites, analogies are known from Salona from the first half of the 1st century (form 3h),³²⁵ and from Zadar.³²⁶

Balsamaria with a bell-shaped body are represented with only one example (pl. 21: 1), and the greatest number of analogies can be found specifically in Croatia (8.6.17.).³²⁷ This form of balsamarium was analyzed by Gluščević, who considered that it had been produced by a workshop in Zadar, as only a few finds of these balsamaria are known outside of Croatia.³²⁸ New publications have broadened the circle of these products, but most are still found in the broader region of the eastern Adriatic coast and in Italy. They can be dated to the 2nd and 3rd centuries on the basis of grave finds from Dalmatia.³²⁹ An identical dating is confirmed by finds from Medulin in Istria.³³⁰

Balsamaria with indentations in the walls (pl. 21: 2) are not common forms (8.6.18.),³³¹ but were manufactured in several variants. They differ in terms of the form of the walls, the length of the neck, the number of indentations, etc. Analogies can be found in Aquileia and in Dalmatia,³³² at Augst,³³³ and in Hungary.³³⁴ The finds from Dalmatia are dated by Fadić to the 3rd and even the 4th centuries,³³⁵ and a balsamarium from Medulin in Istria was dated to the 2nd-3rd centuries,³³⁶ while the Hungarian examples are mainly dated to the 2nd century.³³⁷ Finds from grave units in Slovenia are classified to the 2nd century.³³⁸ The balsamarium from Bakar has a short and wide neck leading directly to a tubular rim. It is dated to the 2nd-3rd centuries.

The balsamarium with spindle-shaped walls (fig. 16 – left) is an isolated example among the finds from Bakar (pl. 21: 3). Few analogies can be found, and the closest are tied to Aquileia³³⁹ and the Croatian region. An almost identical example is in the collection of the Archaeological Museum in Zadar³⁴⁰ and is dated to the 2nd-3rd centuries. The workmanship is somewhat different on a spindle-shaped balsamarium from Salona dated to the 3rd century and attributed to western workshops.³⁴¹ The flask from Bakar would on the basis of its wide mouth, tubular rim, and slightly concave base be dated to the 2nd-3rd centuries.

³²⁷ Lazar 2003, 193; Is 82 a1.

³²⁸ Gluščević 200, 185.

³²⁹ Gluščević 2000, 188.

³³⁰ Girardi Jurkić, Džin 2003, 136, br. 91, 92, 97.

³³¹ Lazar 2003, 193.

³³² Mandruzzato, Marcante 2007, 101, br. 273; Fadić 1997, 81, 85, 86.

³³³ Rütli 1991, 73.

³³⁴ Barkóczy 1988, Taf. 18: 227–236.

³³⁵ Fadić 1997, 33.

³³⁶ Girardi Jurkić, Džin 2003, 138, br. 104.

³³⁷ Barkóczy 1988, 122.

³³⁸ Istenič 2000, 61; Urleb 1984, 313.

³³⁹ Mandruzzato, Marcante 2007, 104, br. 294.

³⁴⁰ Trasprenze 1998, 114, no. 50.

³⁴¹ Buljević 2004, 85.

³²³ Ravagnan 1994, 66, nos. 104, 105.

³²⁴ Ravagnan 1994, 62, nos. 90, 91.

³²⁵ Buljević 2004, 85.

³²⁶ Ravagnan 1994, 68, no. 108.

³²⁷ Lazar 2003, 193; Is 82 a1.

³²⁸ Gluščević 200, 185.

³²⁹ Gluščević 2000, 188.

³³⁰ Girardi Jurkić, Džin 2003, 136, nos. 91, 92, 97.

³³¹ Lazar 2003, 193.

³³² Mandruzzato, Marcante 2007, 101, no. 273; Fadić 1997, 81, 85, 86.

³³³ Rütli 1991, 73.

³³⁴ Barkóczy 1988, pl. 18: 227–236.

³³⁵ Fadić 1997, 33.

³³⁶ Girardi Jurkić, Džin 2003, 138, no. 104.

³³⁷ Barkóczy 1988, 122.

³³⁸ Istenič 2000, 61; Urleb 1984, 313.

³³⁹ Mandruzzato, Marcante 2007, 104, no. 294.

³⁴⁰ Trasprenze 1998, 114, no. 50.

³⁴¹ Buljević 2004, 85.

Zaključna zapažanja

Staklena građa iz rimske nekropole u Bakru nudi djelomičnu sliku o baštini rimskog stakla te s tim u vezi o obrtu, gospodarstvu i trgovini na području sjeverne Dalmacije i jadranske obale u cjelini. S novim podacima u širem kontekstu dopunjujemo dosadašnje poznavanje razvoja i tijek romanizacije te ekonomske odnose toga prostora. Nakon rimskih osvajanja tijekom 2. stoljeća pr. Kr. područje Istre bilo je izravno uključeno u rimsku državu (kasniju X. italsku regiju *Venetia et Histria*), a provincija Ilirik uskoro je bila podijeljena na manje jedinice, na provincije Panoniju i Dalmaciju. Proces romanizacije započeo je dodjeljivanjem prostranih zemljišnih posjeda veteranima i zaslužnim vojnicima. Prisutnost italskih obitelji osobito je opsežno dokumentirana kako u urbanim, tako i u ruralnim središtima od julijevsko-klaudijevskog razdoblja.³⁴² Spomenimo, primjerice, imena *Barbii, Calpurnii, Clodii, Laecanii, Sergii, Tullii, Valerii, Vibii* itd., kojima su se u 2. stoljeću i početkom 3. stoljeća pridružile nove obitelji (među inima: *Anlii, Flaminii, Manlii, Caesernii, Sempronii*).

Latinski jezik, umjetnost, kultura, pismo te ine kulturne stečevine znatno su se širile s velikih posjeda, raspodijeljenih u priobalnom području i zaleđu koji su bili u vlasništvu važnih trgovačkih porodica, cara i članova njegove obitelji. Brojni natpisi govore o oslobođenicima ili carevim sužnjima, carevim namjesnicima, i napokon caru osobno, koji su imali svoje posjede, primjerice na obalnom dijelu Istre.³⁴³ Središta velikih zemljišnih posjeda (*villae rusticae*) slijedimo u nizu od sjevera do juga zapadne istarske obale i u neposrednom zaleđu. Prosječna veličina tih posjeda je, primjerice na području pulskog agera, iznosila oko 118 hektara, odnosno 475 jugera.³⁴⁴ Te rimske vile, za koje je bio potreban precizno doraden i snažan upravni te administrativni aparat, djelovale su kao prava središta proizvodnje, kojima su upravljali pretežno oslobođenici. Na jadranskom su se području uglavnom bavili klesarstvom, opekarstvom, lončarstvom, obradom drva, proizvodnjom ulja, vina i ribarstvom.³⁴⁵ Glavna gospodarska grana u vrijeme Carstva bila je ponajprije uzgoj maslina i vinove loze. Već je Plinije spominjao istarsko ulje kao treće po kvaliteti u cijelom Carstvu, a izvoženo je i u Norik te podunavske provincije. Isti autor govori o kvaliteti i trajnosti vunene odjeće iz Istre; njegove podatke potvrdila su arheološka iskopavanja na sjevernoj

³⁴² Starac 2000; Girardi Jurkić 2003, 25.

³⁴³ Girardi Jurkić 2003, 26.

³⁴⁴ Girardi Jurkić 2003, 27.

³⁴⁵ Matijašić 1998.

Final observations

The discussed glass material from the Roman necropolis at Bakar offers only a partial picture of the heritage of Roman glass and with it the crafts, economy, and trade in the region of northern Dalmatia and the eastern Adriatic coast as a whole. Nonetheless in a broader context the new data definitely supplements previous knowledge of the development and course of Romanization and the economic relations in this area. From the Roman conquest during the 2nd century BC and onwards the region of Istria was directly annexed to the Roman state (*regio Venetia et Histria*), and the province of Illyricum was shortly afterwards divided into smaller units, the provinces of Pannonia and Dalmatia. The process of Romanization began with the allocation of extensive plots of land to veterans and worthy soldiers. The presence of Italic families in particular is extensively documented both in urban and rural centres from the Julian-Claudian period onwards.³⁴² Names can be noted such as *Barbii, Calpurnii, Clodii, Laecanii, Sergii, Tullii, Valerii, Vibii*, etc., who were joined in the 2nd and beginning of the 3rd centuries by new families (including: the *Anlii, Flaminii, Manlii, Caesernii, Sempronii*).

The spread of the Latin language, art, culture, and alphabet, as well as other forms of cultural achievements, took place to a great extent thanks to the large estates located both in the coastal area and inland that were owned by important merchant families, the emperors, and members of their families. Numerous inscriptions tell of freemen or imperial slaves, imperial officials, or even emperors themselves, who had estates in the coastal part of Istria, for example.³⁴³ The large landed estates (*villae rusticae*) can be traced in a line from the north to the south along the western Istrian coast and in its immediate vicinity. The average size of such estates, for instance in the area of the ager of Pula, measured around 118 hectares, or 475 iugerum.³⁴⁴ These Roman villas, which required a precisely assigned and powerful official and administrative apparatus, in fact were active as true production centres, mainly managed by freedmen. They were primarily involved in the Adriatic region with stone-working, tile-making, working wood, producing oil and wine, and fishing.³⁴⁵ The main economic branch in the imperial period was above all the cultivation of olives and grapes. Pliny mentioned the oil from Istria as being the third in quality throughout the entire empire, and it was exported to Noricum and the Danubian provinces. The same author wrote of the quality and durability of woolen

³⁴² Starac 2000; Girardi Jurkić 2003, 25.

³⁴³ Girardi Jurkić 2003, 26.

³⁴⁴ Girardi Jurkić 2003, 27.

³⁴⁵ Matijašić 1998.

obali Istre i otocima.³⁴⁶ Bogata gospodarska osnova bila je temelj žive i bogate trgovine, koja je uključivala obalno područje sa zaleđem kao i trgovinu na duge udaljenosti po cijelom imperiju. U pravilu se trgovina razvila na morskim putovima uzduž Dalmacije i zapadne obale Istre. O tome govore ostaci pristanišnih kompleksa na obali u prirodnim zaljevima, lukobranima, molovima i pristaništima, a također i manji molovi uz morske vile (*villae maritimae*). Ponegdje, pokraj tih kompleksa, otkrivena su manja ili veća skladišta (*horrea*) za sve vrste robe i tereta.

Ispitivanja keramičkih proizvoda (*terra sigillata*, opeke) pokazala su da su pomorski putovi bili izvanredno razvijeni u svim smjerovima.³⁴⁷ Roba iz Veneta već je u prvoj četvrtini 1. stoljeća putovala do Magdalensberga, Emone i na jug do Osora. Malo kasnije su se razvile veze s jadranskim i srednjoitalskim područjem. Veze su tekle između Ravenne i Pule, Picena i Zadra, s Riminijem i Adriom. Opeke iz sjevernoitalskih radionica su u flavijevskom vremenu putovale uzduž dalmatinske obale do Enone i Dokleje u Crnoj Gori.³⁴⁸

U ta živa događanja bila je, nedvojbeno, uključena i trgovina staklom. O njezinu postojanju na jadranskom području govore nalazi s potopljenog broda u blizini Mljeta. Brod je tovaren komadima sirovog stakla iz primarnih staklarskih radionica, vjerojatno negdje na Sredozemlju, kojim su opskrbljivane radionice za sekundarnu proizvodnju.³⁴⁹ Staklarske radionice su,³⁵⁰ što je dokazano ili se još pretpostavlja, djelovale na području Dalmacije i Istre. Staklarska peć bila je otkrivena u vrijeme iskopavanja u Saloni,³⁵¹ iako prema nalazu nju nije moguće usko vremenski odrediti, pretpostavlja se da je djelovala između 1. i 4. stoljeća. Postojanje staklara, odnosno radionice, u gradu potvrđuje ime staklara Pashazija i kalup za izradu dna boca s imenom *Miscenius Ampliatus*.³⁵² S područja Istre spominje se »talonica stakla« na Kravljem rtu kraj Umaga.³⁵³ Nove podatke o mogućem postojanju lokalne staklarske proizvodnje obećavaju i opsežna iskopavanja u Crikvenici.³⁵⁴

O zanimanju za staklarski obrt i novootkrivenu tehniku puhanja stakla govore i uljanice iz 1. stoljeća s prizorom staklarske peći i staklara do nje. Već dugo poznatom nalazu iz Aserije³⁵⁵ prije kratkog vremena pridružila se izvanredno očuvana uljanica iz Spodnjih Škofij blizu Kopra s potpuno identičnim reljefnim prikazom, pronađena kao grobni prilog.³⁵⁶

O raširenosti uporabe staklenih predmeta još od vremena ranog Carstva govore zbirke antičkog stakla iz dalmatinskih mjesta (*Jader, Aenona, Asseria, Argyrunum*), koje su u usporedbi s nalazima kontinentalnog dijela Hrvatske opsežnije i bogatije. Tim zbirkama lako možemo pridodati građu iz rimske nekropole u Bakru (*Volcera*). Objavljena građa doduše pruža sliku uporabe stakla kao grobnog priloga, no stanje istraživanja nam ne omogućuje usporedbe s građom iz naselja na tom području.

clothing from Istria; and his data has been confirmed by archaeological excavations along the northern coast of Istria and on the islands.³⁴⁶ The rich economic base was the foundation for the lively and wealthy trade, which encompassed both the coastal region with its hinterland as well as long-distance trade throughout the entire empire. As a rule the trade developed on the maritime routes extending along Dalmatia and the western coast of Istria. This is indicated by the remains of harbour complexes along the coast in natural bays, by breakwaters, piers, and wharfs, as well as by small jetties serving seaside estates (*villae maritimae*). Additionally such complexes occasionally also contained large or small warehouses (*horrea*) used for all kinds of goods and cargo.

Research into pottery products (*terra sigillata*, tiles) has shown that the maritime routes were exceptionally well developed in all directions.³⁴⁷ Goods from the Veneto region travelled as early as in the first quarter of the 1st century to Magdalensberg, to Emona, and in the south to Osor, and somewhat later connections were established with the Adriatic and central Italian regions. Routes ran between Ravenna and Pula, Picenum and Zadar, and to Rimini and Adria. Tiles from northern Italian workshops traveled in the Flavian period along the Dalmatian coast to Aenona, and to Docleia in present-day Montenegro.³⁴⁸

The glass trade undoubtedly played a major part in such activities. Its existence in the Adriatic region is shown by finds from the shipwreck near the island of Mljet, of a ship that was transporting pieces of raw glass from a first-stage glass workshop probably located somewhere in the Mediterranean to workshops for secondary production,³⁴⁹ as well as the remains from individual glass production centres.³⁵⁰ The latter have been proven or hypothesized to have been active in the area of Dalmatia and Istria. A glass furnace was discovered during excavations at Salona,³⁵¹ although on the basis of the finds it could not be classified specifically and is considered in general to have been active in the period between the 1st and 4th centuries. The existence of glass workshops in the city is also confirmed by the name of a glassmaker *Pashazius*, as well as a mould for making bottle bases with the name *Miscenius Ampliatus*, which further indicates the existence of glass working.³⁵² In the Istrian region, a glass melting-furnace is mentioned to have been located at Kravlji Point near Umag.³⁵³ New data about the possible existence of local glass production centres may also be offered by the recent extensive excavations in Crikvenica.³⁵⁴

The interest in the craft of glassworking and the newly discovered technique of free-blowing is shown by an oil lamp from the 1st century with a depiction of a glass furnace and glassworkers next to it. An already well-known find from Asseria³⁵⁵ has recently been joined by an excellently preserved clay lamp from Spodnje Škofije near Koper, with a completely identical relief depiction, which was found as a grave good.³⁵⁶

³⁴⁶ Girardi Jurkić 2003, 30.

³⁴⁷ Buora 1998, 53.

³⁴⁸ Buora 1998, 52–53.

³⁴⁹ Kisić 2000; Lazar 2003, 210.

³⁵⁰ Fadić 2004, 95.

³⁵¹ Auth 1979; Clairmont 1979.

³⁵² Buljević 2005b, 93.

³⁵³ Girardi Jurkić 2003, 30.

³⁵⁴ Usmeni podatak voditeljice iskopavanja dr. Goranke Lipovac Vrkljan sa Instituta za arheologiju u Zagrebu, za koji joj se iskreno zahvaljujem.

³⁵⁵ Abramić 1957.

³⁵⁶ Lazar 2004; 2005b.

³⁴⁶ Girardi Jurkić 2003, 30.

³⁴⁷ Buora 1998, 53.

³⁴⁸ Buora 1998, 52–53.

³⁴⁹ Kisić 2000; Lazar 2003, 210.

³⁵⁰ Fadić 2004, 95.

³⁵¹ Auth 1979; Clairmont 1979.

³⁵² Egger Buljević 2005b, 93.

³⁵³ Girardi Jurkić 2003, 30.

³⁵⁴ Personal communication from the excavation director, Dr. Goranka Lipovac Vrkljan of the Institute of Archaeology in Zagreb, for which I sincerely thank her.

³⁵⁵ Abramić 1957.

³⁵⁶ Lazar 2004; 2005b.



Sl. 17 Vrčič (aryballos) od obojenog jantarnog i plavog stakla | Fig. 17 Aryballos made of amber coloured and blue glass

Stoga ta slika nije nužno identična s građom koja je bila raširena i upotrebljavana u svakidašnjem životu. Uništene grobne cjeline su uzrok da temeljita socijalna analiza groblja nažalost nije moguća. Usporedba sa staklom na ostalim jadranskim nalazištima, onima u Italiji i zaleđu Jadrana, svejedno omogućuje stanovite zaključke i tvrdnje.

Vremenski raspon očuvane građe seže od početka 1. stoljeća do kraja 3. stoljeća, a težište je na razdoblju između druge pol. 1. i 2. st. Rana građa je tijekom 1. st. stizala na Jadran većinom uz posredovanje Akvileje, koja je bila glavno trgovačko središte za brojne staklarske radionice sjevernog i istočnog dijela Italije. Značajni italski proizvodi u prvoj polovini i sredinom 1. st. su tanjuri bez noge i sa stijenkama koje prelaze ravno u rub, zdjelice oblika Is 41, vrčevi kuglastog i ovalnog oblika te mali kuglasti i piriformni balzamariji. Ostali su i neki pojedinačni proizvodi kozmetičkog posuđa iz sredozemnih radionica (t. 15: 4). Sve to posuđe je u nekoliko slučajeva izrađeno od obojenog stakla koje je u to vrijeme bilo još vrlo omiljeno. Prevladavaju kobaltnoplava, jantarna i ljubičasta boja (sl. 3, 14, 17).

U drugoj pol. 1. st. raspon oblika povećan je u prvom redu zbog brojnog transportnog posuđa i posuđa za pohranu. Prevladavalo je prirodno obojeno staklo modrozelenkastog tona, a kvalitetni proizvodi izrađeni su od dekoloriranog, namjerno razbojanog stakla. Moda bezbojnog stakla koja oponaša proizvode od gorskog kristala (prozirca) nadomještala je nekadašnju želju za bojama povezanu s dragocjenim proizvodima od mozaičnog stakla. Brojne oblike boca i žara dopunjuju od stolnog posuđa tanjuri i zdjelice sa široko razgrnutim rubom, različite čaše od tanko puhanog stakla, raznovrsne čaše s udubljenjima (naboranim stijenkama), a od balzamarija najrašireniji su cjevasti oblici te posudice s trokutasto oblikovanim tijelom.

Proizvodima iz italskih radionica u 2. se stoljeću pridružilo posuđe sa Sredozemlja, ponajprije iz ciparskih središta. To su tanjuri i posudice s aplikacijama na obodu, odnosno rubu posude te veće zdjele na visokoj nozi koje oponašaju omiljene, u kalupu rađene proizvode od dekoloriranog stakla s facetiranim ukrasom. Pojedini oblici, primjerice velika boca (t. 11; sl. 11), svjedoče da je jadranska trgovina imala dodire i s maloazijskim gradovima. Među građom iz 2. i 3. stoljeća nema proizvoda porajnskih središta što govori da je tada područje bilo povezano prvenstveno sa Sredozemljem. Imućni pojedinci kojih, sudeći prema veleposjedima i cvatućem gospodarstvu nije bilo malo, lako su osmislili iznimne proizvode pojedinih radionica. Oni nisu bili dio masovne proizvodnje jeftinog stakla za svakidašnju uporabu. Takav primjer je zdjela iz radionice u Egiptu (t. 5; sl. 6), koja pripada uskoj skupini proizvoda s urezanim i brušenim figuralnim ukrasom koji se naziva »*contour groove group*«.

Ako smo za ranu građu iz Bakra našli najviše analogija na jadranskim nalazištima, od kraja 1. st. i u 2. stoljeću opažamo više sličnosti i na unutrašnjem području, što ukazuje na raširenost uporabe stakla i u zaleđu Hrvatske, na području Panonije i uporabu jednakih, najraširenijih nadregionalnih oblika (čaše s udubljenjima, boce, žare) toga vremena.

U 3. je stoljeću raznolikost oblika i njihovih inačica polako počela opadati, a prevladavale su različite boce i zdjelice te balzamariji. Pojedini oblici balzamarija (t. 18: 4–6; 21: 1) i tzv. pseudo Merkur-bočice (t. 16: 2) su forme koje određujemo kao proizvod lokalnih staklarskih radionica. Potonje je takvima odredio još I. Fadić,³⁵⁷ iako im točnu provenijenciju nije moguće odrediti dok ne budu dokazana arheološkim iskopavanjima. Njihova rasprostranjenost

The widespread use of glass products from the period of the earliest empire is clearly indicated by the collections of Roman glass from Dalmatian cities (*Iader, Aenona, Asseria, Argyruntum*), which in comparison to the finds from the continental part of Croatia are both richer and more extensive. Today the material from the Roman necropolis in Bakar (*Volcera*) can be rightfully added to these collections. The published material only offers an image of the use of glass products as grave goods, and the present state of research does not offer comparisons to the settlement material from this region. Hence such an image is not always identical to the material that was truly widespread and utilized in everyday life. The destroyed grave units also contribute to the fact that no fundamental social analysis of the cemeteries can be performed. The comparison of the material with the glass from the Adriatic coastal sites, as well as sites in Italy and the Adriatic hinterland, nonetheless enables certain conclusions and claims.

The chronological span of the preserved material extends from the beginning of the 1st century to the end of the 3rd century, with an emphasis on the period between the second half of the 1st and the 2nd centuries. The earlier material arrived in the Adriatic during the 1st century primarily through Aquileia, which was also the main trade centre for the numerous glass production centres of the northern and eastern parts of Italy. Characteristic Italic products of the first half and middle of the 1st century are plates without a foot and with walls with a direct transition to the rim, bowls of form Is 41, globular and oval jugs, and small globular and pear-shaped balsamaria. The material also includes several individual cosmetic vessels produced in Mediterranean workshops (pl. 15: 4). All of these vessels in several cases were also made of coloured glass, which was still highly popular at that time. Cobalt blue, amber, and purple predominate (fig. 3, 14, 17).

In the second half of the 1st century, the range of forms increased, primarily because of the numerous vessels for storage and transport. Naturally coloured glass with blue-green tones predominated, while high quality products were made from deliberately decoloured glass. The fashion of colourless glass that imitated products made of rock crystal replaced the former desire for colours, which had been related to valuable mosaic glass products. Numerous forms of bottles and jars were joined by plates and bowls with a wide splayed rim among tableware, along with various goblets from thinly blown glass, and various small beakers with indentations, while among the balsamaria tubular shapes were most widespread, along with small flasks with triangular bodies.

The products from Italic workshops were joined in the 2nd century by vessels from the Mediterranean, particularly from the Cyprian production centres. These were plates and bowls with applied elements on the rim and also large bowls on a high foot that imitate popular mould made products of decoloured glass with facet-cut decoration. Individual forms, such as a tall bottles (pl. 11; fig. 11), indicate that the Adriatic trade also had contacts with towns in Asia Minor. Among the material from the 2nd and 3rd centuries there are no products from the Rhine valley production centres, indicating that the region at that time was primarily connected with the Mediterranean. Wealthy individuals, who seem on the basis of the major estates and flourishing economy to have been common, could have ordered exceptional products from individual workshops that were not a part of the mass production of cheap glass for everyday use. One example is a bowl from an Egyptian workshop (pl. 5; fig. 6), which belongs to a small group of products with incised and ground decoration that is called the '*contour groove group*'.

If the greatest number of analogies for the early material from Bakar was found at sites along the Adriatic coast, from the end of the 1st

³⁵⁷ Fadić 1987, 13; 2004, 100.

na širem području Dalmacije daje naslutiti njihov nastanak i trgovinu u jednom od obalnih gradova istočnog Jadrana.

Grobne cjeline u Bakru nisu poznate, odnosno sačuvane, a pri traženju analogija nehotice smo opazili veliku sličnost među staklenom građom nekropole u Albengi (*Albigaunum*) u Liguriji i građe s hrvatske strane obale.³⁵⁸ Ligurijska nekropola pokazuje jednak vremenski raspon s naglaskom na drugu pol. 1. i 2. st.³⁵⁹ Za usporedbu navodimo pojavljivanje određenih staklenih oblika u grobovima: gr. 18 – spljošteni balzamariji i zdjela na visokoj nozi,³⁶⁰ čaša s udubljenjima kvadratne forme i zvonasti balzamariji u grobu 17,³⁶¹ vrč s izljevom, polukuglaste zdjelice, kuglaste žare te tri oblika balzamarija (8.6.2., 8.6.6. in 8.6.9.) u grobu 26,³⁶² čaša s udubljenjima i polukuglasta zdjelica u grobu 28,³⁶³ tanjur s aplikacijom zajedno s više polukuglastih zdjelica i balzamarija oblika 8.6.9. u grobu 32,³⁶⁴ ako spomenemo samo najznačajnije primjere. Na temelju toga moguće je steći uvid u sadržaj uništenih grobnih cjelina, iako nam za potpunu sliku još nedostaje keramička i metalna građa.

Utvrđujemo, na kraju, kako je istraživana staklena građa odraz razvijenog gospodarskog života na obalama Jadrana od vremena Carstva nadalje. Područje je bilo stjecište zapadnih i istočnih utjecaja. Brojna pristaništa služila su kao trgovačka uporišta za područje istočnog Sredozemlja, a živost gospodarstva, trgovine i procvat u 1. stoljeću posredno je pokazala i staklena građa iz Bakra. Nedostaju predmeti iz ranog razdoblja osvajanja toga prostora, a u 1. i 2. stoljeću zbio se potpun procvat uporabe stakla u rimskoj svakidašnjici, s bogatstvom oblika koji su nastali u uvažanim staklarskim središtima, a malo kasnije i u lokalnim radionicama. Tijekom 3. stoljeća, kad su se već počele javljati promjene u kulturi svakidašnjeg života pri uporabi stakla, koje su odražavale gospodarske teškoće i globalne pomake u ekonomiji države, vjerojatno je polako zamirala i nekropola u Bakru. Možda se smanjio njezin opseg, možda su je preselili drugamo zbog odnosa u gradu. Odgovor će dati nova istraživanja i suvremena arheološka iskopavanja na području *Volcera*.

century and in the 2nd century more comparisons can also be noted in the inland region, which reflects the spread of the use of glass into the continental parts of Croatia and the region of Pannonia, and the use of identical most widespread and supra-regional forms (indented beakers, bottles, jars) of the time.

In the 3rd century, the diversity of forms and their variants slowly declines, and various bottles and bowls and balsamaria predominate. Some forms of balsamaria in particular (pl. 18: 4-6; 21: 1) and also the so-called pseudo-Mercury flasks (pl. 16: 2) are forms that can be defined as products of local glass workshops. The latter had previously been classified in this manner by I. Fadić,³⁵⁷ although their exact provenience cannot be determined until it is proven by archaeological excavation. Their distribution throughout the broader area of Dalmatia suggests their origin and marketing in one of the coastal cities of the eastern Adriatic.

The grave units at Bakar were not preserved and are hence unknown, and while searching for analogies quite by chance a great similarity was noted between the glass material from the necropolis at Albenga (*Albigaunum*) in Liguria and the material from the Croatian Adriatic coast.³⁵⁸ The Ligurian cemetery exhibits an identical chronological span, with an emphasis on the second half of the 1st and the 2nd centuries.³⁵⁹ For comparative purposes, the appearance of certain glass forms in graves can be noted: grave 18 – flattened balsamaria and a bowl on a tall foot,³⁶⁰ an indented beaker of rectangular form and bell-shaped balsamaria in grave 17,³⁶¹ a jug with a spout, hemispherical bowls, globular jars, and three forms of balsamaria (8.6.2, 8.6.6, and 8.6.9) in grave 26,³⁶² an indented beaker and hemispherical bowl in grave 28,³⁶³ a plate with an applied element together with several hemispherical bowls and a balsamarium of form 8.6.9 in grave 32,³⁶⁴ if only the most significant examples are cited. This aids in recovering the possible composition of the destroyed grave units, although for a more complete image, the pottery and metal material is still lacking.

It can be established in conclusion that the analyzed glass material reflected the flourishing economic situation on the coast of the Adriatic from the imperial period and onwards. The region was the meeting point of western and eastern influences. The numerous harbours served as trade bases for the eastern Mediterranean area, and the lively economy, trade, and general prosperity is indirectly shown through the glass material from Bakar. If objects from the early period of the conquest and subjugation of this region are lacking, those from the 1st and 2nd centuries depict a complete explosion in the use of glass in everyday life, with a wealth of form and type created in prominent glass production centres, and somewhat later also in local workshops. During the 3rd century, when changes in the culture of everyday life in terms of the use of glass began to become apparent, as the first reflection of economic difficulties as well as global shifts in the economy of the state, the cemetery at Bakar also probably began slowly to decline. Perhaps its extent was reduced, perhaps it was moved elsewhere because of conditions in the town – answers to this will only be supplied by new research and modern archaeological excavations in the area of ancient *Volcera*.

³⁵⁸ Massabò 1999.

³⁵⁹ Macabruni 1999, 157.

³⁶⁰ Massabò 1999, 246.

³⁶¹ Id. 243.

³⁶² Id. 247.

³⁶³ Id. 249.

³⁶⁴ Id. 251.

³⁵⁷ Fadić 1987, 13; 2004, 100.

³⁵⁸ Massabò 1999.

³⁵⁹ Macabruni 1999, 157.

³⁶⁰ Massabò 1999, 246.

³⁶¹ Id. 243.

³⁶² Id. 247.

³⁶³ Id. 249.

³⁶⁴ Id. 251.

Popis literature / Bibliography

- ABRAMIĆ 1959:** Mihovil Abramić, Eine römische Lampe mit Darstellung des Glasblasens, *Bonner Jahrbücher* 159, 149–151.
- ALARCÃO 1981:** Jorge de Alarcão, Roman Glass from Troia (Portugal), u/in: *Annales du 8e Congrès de l'AIHV*, Liège, 1005–110.
- AMREIN 2006:** Heidi Amrein, Marques sur verres attestées en Suisse, u/in: D. Foy, M.-D. Nenna (eds.), *Corpus des signatures et marques sur verres antiques*, vol. 2, AFAV, Aix-en-Provence, Lyon, 209–244.
- AMREIN & NENNA 2006:** Heidi Amrein, Marie-Dominique Nenna, Inventaire des moules destinés à la fabrication des contenats de verre, u/in: D. Foy, M.-D. Nenna (eds.), *Corpus des signatures et marques sur verres antiques*, Vol. 2, AFAV, Aix-en-Provence, Lyon, 491–502.
- ARVEILLER & NENNA 2006:** Véronique Arveiller, Marie-Dominique Nenna, Marques conservées dans les musées français de provenance inconnue ou étrangère, u/in: D. Foy, M.-D. Nenna (eds.) 2006, *Corpus des signatures et marques sur verres antiques*, vol. 1– La France, AFAV, Aix en Provence – Lyon, 201–214.
- ARTE CULTURA CROAZIA 1993:** Arte e cultura in Croazia, Collezioni del Museo archeologico di Zagabria, Zagreb.
- AUTH 1975:** Susan Auth, Roman Glass, u/in: *Clairmont C. W., Excavations at Salona, Yugoslavia (1969–1972)*, Park Ridge, New York.
- BARAG 1967:** Dan Barag, »Flower and bird« and snake-thread Glass Vessels, u / in: *Annales du 4e Congrès de l'AIHV*, Liège, 55–66.
- BARAG 1978:** Dan Barag, Hanita, Tomb XV. A Tomb of the Third and Early Fourth Century CE, *Atiqot-English Series* 13, 1–60.
- BARKÓCZI 1981:** László Barkóczy, Kelche aus Pannonien mit Fadenaufgabe und Gravierung, *Acta Archaeologica Academiae Scientiarum Hungaricae* 33, 35–70.
- BARKÓCZI 1988:** László Barkóczy, *Pannonische Glasfunde in Ungarn*, *Studia Archaeologica* 9, Budapest.
- BERGER 1960:** Ludwig Berger, *Römische Gläser aus Vindonissa*, Veröffentlichungen der Gesellschaft pro Vindonissa 4.
- BIAGGIO SIMONA 1991:** Simonetta Biaggio Simona, *I vetri romani provenienti dalle terre dell'attuale cantone Ticino*, I–II. Armando Dadò editore, Locarno.
- BONOMI 1996:** Simonetta Bonomi, *Vetri antichi del Museo Archeologico Nazionale di Adria*, *Corpus CCAV 2*, Venezia.
- BULJEVIĆ 1999:** Zrinka Buljević, *Stakleni balzamariji iz Salone*, Zadar (neobjavljeni magistarski rad / *unpublished MA dissertation*), Filozofski fakultet u Zadru.
- BULJEVIĆ 2000:** Zrinka Buljević, Sferični i pticolikli balzamariji iz Arheološkog muzeja Split, *Opuscula Archaeologica* 23–24, 465–472.
- BULJEVIĆ 2002:** Zrinka Buljević, Monokromni stakleni tanjuri, u/in: E. Marin (ed.) *Longae Saloniae* II, 207–211.
- BULJEVIĆ 20003:** Zrinka Buljević, Naronitansko staklo, *Izdanja HAD* 22, 85–117.
- BULJEVIĆ 2004A:** Zrinka Buljević, The Glass, u/ in: E. Marin, M. Vickers (eds.), *The Rise and Fall of an Imperial Shrine. Roman Sculpture from the Augusteum at Narona*, *Narona VII*, Split, 186–209.
- BULJEVIĆ 2004B:** Zrinka Buljević, Stakleni balzamariji iz Salone, u/in: I. Lazar (ed.), *Drobc antičnega stekla – Fragments of Ancient Glass*, *Annales Mediterranea*, Koper, 81–94.
- BULJEVIĆ 2005A:** Zrinka Buljević, Salonitanski kalup s prikazom gladijatora / Salona mold with image of gladiators, *Opuscula archaeologica* 28, 193–202.
- BULJEVIĆ 2005B:** Zrinka Buljević, Tragovi staklara u rimskoj provinciji Dalmaciji / *Traces of Glassmakers in Roman Province of Dalmatia*, *Vjesnik za arheologiju i povijest dalmatinsku* 98, Split, 93–106.
- BUORA 1998:** Maurizio Buora, Rotte e commerci nell'Adriatico in epoca romana, u/in: *Trasparenze 1998*, 51–56.
- BUORA 2004A:** Maurizio Buora, Il corpus dei vetri romani del Veneto e la sua sperabile continuazione per i vetri romani del Friuli, u/in: I. Lazar (ed.), *Drobc antičnega stekla – Fragments of Ancient Glass*, *Annales Mediterranea*, Koper, 149–152.
- BUORA 2004B:** Maurizio Buora, *Vetri antichi del Museo Archeologico di Udine*, *Corpus delle collezioni del vetro in Friuli Venezia Giulia* 1, Trieste.
- BURKOWSKY 1999:** Zdenko Burkowsky, *Sisak u prapovijesti, antici i starohrvatskom dobu*, Sisak.
- CALVI 1968:** Carina Calvi, *I vetri romani del Museo di Aquileia*, Aquileia.
- CESELIN 1997:** Francesco Ceselin, Vetri romani provenienti dal Parmese e da Velleia, *Diadora* 18/19, 1996/97, 145–193.
- CASAGRANDE & CESELIN 2003:** Claudia Casagrande, Francesco Ceselin, *Vetri antichi delle province di Belluno, Treviso e Vicenza*, *CCAV 7*, Venezia.
- CLAIRMONT 1975:** Christoph. W. Clairmont, *Excavations at Salona, Yugoslavia (1969–1972)*, Park Ridge, New York.
- COOL & PRICE 1995:** Hilary E. M. Cool, H. Jennifer Price, *Roman Vessel Glass*, *Colchester Archaeological Report* 8, Colchester.
- CZURDA-RUTH 1979:** Barbara Czurda-Ruth, *Die römischen Gläser vom Magdalensberg*, *Kärntner Museumsschriften* 65, Klagenfurt.
- DAMEVSKI 1976:** Valerija Damevski, Pregled tipova staklenog posuđa iz italskih, galskih, mediteranskih i porajnskih radionica na području Hrvatske u doba rimskog Carstva, *Arheološki vestnik* 25, 62–75.
- DE TOMMASO 1990:** Giandomenico De Tommaso, *Ampulae vitreae. Contenitori in vetro di unguenti e sostanze aromatiche dell'Italia romana (I sec. a.C.-III sec. d.C.)*, *Archaeologica* 94, Roma.
- FACCHINI 1995:** Giuliana M. Facchini et al., Studio di una forma vitrea di età romana: la Merkurflasche (forma Isings 84), *Postumia* 6, 150–173.
- FADIĆ 1987:** Ivo Fadić, *Antičko staklo Argyruntuma*, Katalog izložbe / exhibition catalogue, Zadar.
- FADIĆ 1995:** Ivo Fadić, Staklene boce iz muzeja u Cresu, *Petriciolijev zbornik, Prilozi povijesti umjetnosti u Dalmaciji* 35, 185–201.
- FADIĆ 1997:** Ivo Fadić, *Antičko staklo Argyruntuma*, Katalozi 3, Zadar.
- FADIĆ 1998:** Ivo Fadić, Il vetro, u/in: *Trasparenze imperiali. Vetri romani dalla Croazia, catalogo della mostra*, Milano, 73–238.
- FADIĆ 2004:** Ivo Fadić, Antičke staklarske radionice u Hrvatskoj – Ancient glass workshops in the territory of Modern Croatia, u/in: I. Lazar (ed.), *Drobc antičnega stekla – Fragments of Ancient Glass*, *Annales Mediterranea*, Koper, 95–106.
- FASSOLD 1985:** Peter Fassold, Die früh- und mittelrömischen Gläser von Kempten – Cambodunum, u/in: J. Bellot, W. Cysz, G. Krahe, *Forschungen zur Provinzialrömischen Archäologie in Bayerisch-Schwaben*, Schwäb, *Geschichtsquellen und Forschungen* 14, Augsburg, 197–230.
- FOY 2006 :** Danièle Foy, Marques sur verres découvertes dans le Maghreb, u/in : D. Foy, M.-D. Nenna (eds.), *Corpus des signatures et marques sur verres antiques*, vol. 2, AFAV, Aix-en-Provence, Lyon, 349–368.
- FOY & NENNA 2006A:** Danièle Foy, Marie-Dominique Nenna (eds.) 2006, *Corpus des signatures et marques sur verres antiques*, vol. 1– La France, AFAV, Aix en Provence – Lyon.
- FOY, NENNA 2006B:** Danièle Foy, Marie-Dominique Nenna, Les marques dans les grand sud-est de la France, u/in : D. Foy, M.-D. Nenna (eds.) 2006a, *Corpus des signatures et marques sur verres antiques*, vol. 1- La France, AFAV, Aix en Provence – Lyon, 55–64.
- FREMERSDORF 1951:** Fritz Fremersdorf, *Figürlich geschliffene Gläser*, *Römisch-Germanische Forschungen* 19, Köln.
- FREMERSDORF 1958:** Fritz Fremersdorf, *Das Naturfarbene sogennante blaugrüne Glass in Köln*, *Die Denkmäler des römischen Köln* 4, Köln.
- FREMERSDORF 1959:** Fritz Fremersdorf, *Römische Gläser mit Fadenaufgabe in Köln*, *Die Denkmäler des römischen Köln* 5, Köln.
- FREMERSDORF & POLÓNYI-FREMERSDORF 1984:** Fritz Fremersdorf i Eleni Polónyi-Fremersdorf, *Die Farblosen Gläser der Frühzeit in Köln*, *Die Denkmäler des römischen Köln* 9, Köln.
- FRIEDHOFF 1991:** Ulrich Friedhoff, *Der römische Friedhof an der Jakobstraße zu Köln*, *Kölner Forschungen* 3, Mainz.
- FROVA 1971:** Antonio Frova 1971, Vetri romani con marchi, *Journal of Glass Studies* 13, 38–44.
- FÜNFSCILLING 1999:** Sylvia Fünfschilling, Die geschlossene Form – Flaschen, Kannen, Krüge in spätrömischer Zeit, u / in: M. J. Klein (ed.) *Römische Glaskunst und Wandmalerei*, Mainz, 78–90.

Popis literature / Bibliography

- ABRAMIĆ 1959:** Mihovil Abramić, Eine römische Lampe mit Darstellung des Glasblasens, *Bonner Jahrbücher* 159, 149–151.
- ALARCÃO 1981:** Jorge de Alarcão, Roman Glass from Troia (Portugal), u/in: *Annales du 8e Congrès de l'AIHV*, Liège, 1005–110.
- AMREIN 2006:** Heidi Amrein, Marques sur verres attestées en Suisse, u/in: D. Foy, M.-D. Nenna (eds.), *Corpus des signatures et marques sur verres antiques, vol. 2*, AFAV, Aix-en-Provence, Lyon, 209–244.
- AMREIN & NENNA 2006:** Heidi Amrein, Marie-Dominique Nenna, Inventaire des moules destinés à la fabrication des contenats de verre, u/in: D. Foy, M.-D. Nenna (eds.), *Corpus des signatures et marques sur verres antiques, Vol. 2*, AFAV, Aix-en-Provence, Lyon, 491–502.
- ARVEILLER & NENNA 2006:** Véronique Arveiller, Marie-Dominique Nenna, Marques conservées dans les musées français de provenance inconnue ou étrangère, u/in: D. Foy, M.-D. Nenna (eds.) 2006, *Corpus des signatures et marques sur verres antiques, vol. 1 – La France*, AFAV, Aix en Provence – Lyon, 201–214.
- ARTE CULTURA CROAZIA 1993:** Arte e cultura in Croazia, Collezioni del Museo archeologico di Zagabria, Zagreb.
- AUTH 1975:** Susan Auth, Roman Glass, u/in: *Clairmont C. W., Excavations at Salona, Yugoslavia (1969–1972)*, Park Ridge, New York.
- BARAG 1967:** Dan Barag, »Flower and bird« and snake-thread Glass Vessels, u / in: *Annales du 4e Congrès de l'AIHV*, Liège, 55–66.
- BARAG 1978:** Dan Barag, Hanita, Tomb XV. A Tomb of the Third and Early Fourth Century CE, *Atiqot-English Series* 13, 1–60.
- BARKÓCZI 1981:** László Barkóczy, Kelche aus Pannonien mit Fadenaufgabe und Gravierung, *Acta Archaeologica Academiae Scientiarum Hungaricae* 33, 35–70.
- BARKÓCZI 1988:** László Barkóczy, *Pannonische Glasfunde in Ungarn*, *Studia Archaeologica* 9, Budapest.
- BERGER 1960:** Ludwig Berger, *Römische Gläser aus Vindonissa*, Veröffentlichungen der Gesellschaft pro Vindonissa 4.
- BIAGGIO SIMONA 1991:** Simonetta Biaggio Simona, *I vetri romani provenienti dalle terre dell'attuale cantone Ticino*, I–II. Armando Dadò editore, Locarno.
- BONOMI 1996:** Simonetta Bonomi, *Vetri antichi del Museo Archeologico Nazionale di Adria*, *Corpus CCAV 2*, Venezia.
- BULJEVIĆ 1999:** Zrinka Buljević, *Stakleni balzamariji iz Salone*, Zadar (neobjavljeni magistarski rad / *unpublished MA dissertation*), Filozofski fakultet u Zadru.
- BULJEVIĆ 2000:** Zrinka Buljević, Sferični i pticolikali balzamariji iz Arheološkog muzeja Split, *Opuscula Archaeologica* 23–24, 465–472.
- BULJEVIĆ 2002:** Zrinka Buljević, Monokromni stakleni tanjuri, u/in: E. Marin (ed.) *Longae Salona* II, 207–211.
- BULJEVIĆ 2003:** Zrinka Buljević, Naronitansko staklo, *Izdanja HAD* 22, 85–117.
- BULJEVIĆ 2004A:** Zrinka Buljević, The Glass, u/ in: E. Marin, M. Vickers (eds.), *The Rise and Fall of an Imperial Shrine. Roman Sculpture from the Augusteum at Narona*, *Narona VII*, Split, 186–209.
- BULJEVIĆ 2004B:** Zrinka Buljević, Stakleni balzamariji iz Salone, u/in: I. Lazar (ed.), *Drobc antičnega stekla – Fragments of Ancient Glass*, *Annales Mediterranea*, Koper, 81–94.
- BULJEVIĆ 2005A:** Zrinka Buljević, Salonitanski kalup s prikazom gladijatora / Salona mold with image of gladiators, *Opuscula archaeologica* 28, 193–202.
- BULJEVIĆ 2005B:** Zrinka Buljević, Tragovi staklara u rimskoj provinciji Dalmaciji / *Traces of Glassmakers in Roman Province of Dalmatia*, *Vjesnik za arheologiju i povijest dalmatinsku* 98, Split, 93–106.
- BUORA 1998:** Maurizio Buora, Rotte e commerci nell'Adriatico in epoca romana, u/in: *Trasparenze 1998*, 51–56.
- BUORA 2004A:** Maurizio Buora, Il corpus dei vetri romani del Veneto e la sua sperabile continuazione per i vetri romani del Friuli, u/in: I. Lazar (ed.), *Drobc antičnega stekla – Fragments of Ancient Glass*, *Annales Mediterranea*, Koper, 149–152.
- BUORA 2004B:** Maurizio Buora, *Vetri antichi del Museo Archeologico di Udine*, *Corpus delle collezioni del vetro in Friuli Venezia Giulia* 1, Trieste.
- BURKOWSKY 1999:** Zdenko Burkowsky, *Sisak u prapovijesti, antici i starohrvatskom dobu*, Sisak.
- CALVI 1968:** Carina Calvi, *I vetri romani del Museo di Aquileia*, Aquileia.
- CESELIN 1997:** Francesco Ceselin, Vetri romani provenienti dal Parmese e da Velleia, *Diadora* 18/19, 1996/97, 145–193.
- CASAGRANDE & CESELIN 2003:** Claudia Casagrande, Francesco Ceselin, *Vetri antichi delle province di Belluno, Treviso e Vicenza*, *CCAV 7*, Venezia.
- CLAIRMONT 1975:** Christoph. W. Clairmont, *Excavations at Salona, Yugoslavia (1969–1972)*, Park Ridge, New York.
- COOL & PRICE 1995:** Hilary E. M. Cool, H. Jennifer Price, *Roman Vessel Glass*, *Colchester Archaeological Report* 8, Colchester.
- CZURDA-RUTH 1979:** Barbara Czurda-Ruth, *Die römischen Gläser vom Magdalensberg*, *Kärntner Museumsschriften* 65, Klagenfurt.
- DAMEVSKI 1976:** Valerija Damevski, Pregled tipova staklenog posuđa iz italskih, galskih, mediteranskih i porajnskih radionica na području Hrvatske u doba rimskog Carstva, *Arheološki vestnik* 25, 62–75.
- DE TOMMASO 1990:** Giandomenico De Tommaso, *Ampulae vitreae. Contenitori in vetro di unguenti e sostanze aromatiche dell'Italia romana (I sec. a.C.-III sec. d.C.)*, *Archaeologica* 94, Roma.
- FACCHINI 1995:** Giuliana M. Facchini et al., Studio di una forma vitrea di età romana: la Merkurflasche (forma Isings 84), *Postumia* 6, 150–173.
- FADIĆ 1987:** Ivo Fadić, *Antičko staklo Argyruntuma*, Katalog izložbe / exhibition catalogue, Zadar.
- FADIĆ 1995:** Ivo Fadić, Staklene boce iz muzeja u Cresu, *Petriciolijev zbornik, Prilozi povijesti umjetnosti u Dalmaciji* 35, 185–201.
- FADIĆ 1997:** Ivo Fadić, *Antičko staklo Argyruntuma*, *Katalozi* 3, Zadar.
- FADIĆ 1998:** Ivo Fadić, Il vetro, u/in: *Trasparenze imperiali. Vetri romani dalla Croazia, catalogo della mostra*, Milano, 73–238.
- FADIĆ 2004:** Ivo Fadić, Antičke staklarske radionice u Hrvatskoj – Ancient glass workshops in the territory of Modern Croatia, u/in: I. Lazar (ed.), *Drobc antičnega stekla – Fragments of Ancient Glass*, *Annales Mediterranea*, Koper, 95–106.
- FASSOLD 1985:** Peter Fassold, Die früh- und mittelrömischen Gläser von Kempten – Cambodunum, u/in: J. Bellot, W. Cysz, G. Krahe, *Forschungen zur Provinzialrömischen Archäologie in Bayerisch-Schwaben*, Schwäb, *Geschichtsquellen und Forschungen* 14, Augsburg, 197–230.
- FOY 2006 :** Danièle Foy, Marques sur verres découvertes dans le Maghreb, u/in : D. Foy, M.-D. Nenna (eds.), *Corpus des signatures et marques sur verres antiques, vol. 2*, AFAV, Aix-en-Provence, Lyon, 349–368.
- FOY & NENNA 2006A:** Danièle Foy, Marie-Dominique Nenna (eds.) 2006, *Corpus des signatures et marques sur verres antiques, vol. 1 – La France*, AFAV, Aix en Provence – Lyon.
- FOY, NENNA 2006B:** Danièle Foy, Marie-Dominique Nenna, Les marques dans les grand sud-est de la France, u/in : D. Foy, M.-D. Nenna (eds.) 2006a, *Corpus des signatures et marques sur verres antiques, vol. 1- La France*, AFAV, Aix en Provence – Lyon, 55–64.
- FREMERSDORF 1951:** Fritz Fremersdorf, *Figürlich geschliffene Gläser*, *Römisch-Germanische Forschungen* 19, Köln.
- FREMERSDORF 1958:** Fritz Fremersdorf, *Das Naturfarbene sogennante blaugrüne Glass in Köln*, *Die Denkmäler des römischen Köln* 4, Köln.
- FREMERSDORF 1959:** Fritz Fremersdorf, *Römische Gläser mit Fadenaufgabe in Köln*, *Die Denkmäler des römischen Köln* 5, Köln.
- FREMERSDORF & POLÓNYI-FREMERSDORF 1984:** Fritz Fremersdorf i Eleni Polónyi-Fremersdorf, *Die Farblosen Gläser der Frühzeit in Köln*, *Die Denkmäler des römischen Köln* 9, Köln.
- FRIEDHOFF 1991:** Ulrich Friedhoff, *Der römische Friedhof an der Jakobstraße zu Köln*, *Kölner Forschungen* 3, Mainz.
- FROVA 1971:** Antonio Frova 1971, Vetri romani con marchi, *Journal of Glass Studies* 13, 38–44.
- FÜNFSCILLING 1999:** Sylvia Fünfschilling, Die geschlossene Form – Flaschen, Kannen, Krüge in spätrömischer Zeit, u / in: M. J. Klein (ed.) *Römische Glaskunst und Wandmalerei*, Mainz, 78–90.

- GIRARDI JURKIĆ 2003:** Vesna Girardi Jurkić, Istra u rimsko doba, u/in: Vesna Girardi Jurkić i Kristina Džin, *Sjaj antičkih nekropola Istre*, Monografije i katalozi 13, Pula, 15–46.
- GIRARDI JURKIĆ & DŽIN 2003:** Vesna Girardi Jurkić i Kristina Džin, *Sjaj antičkih nekropola Istre*, Monografije i katalozi 13, Pula.
- GLÖCKNER 2006:** Gudrun Glöckner, Signs, inscriptions and other designs on Roman glass vessels in Austria, u/in: D. Foy, M.-D. Nenna (eds.), *Corpus des signatures et marques sur verres antiques, vol. 2, AFAV, Aix-en-Provence, Lyon, 187–208*.
- GLUŠČEVIĆ 1986:** Smiljan Gluščević, Some forms of Glass Material from the Romna Harbour of Zaton near Zadar, *Arheološki vestnik* 37, 255–276.
- GLUŠČEVIĆ 1999:** Smiljan Gluščević, Kvadratične staklene boce s pečatom iz rimske luke u Zatonu, *Diadora* 13, 1991, 147–198.
- GLUŠČEVIĆ 1993:** Smiljan Gluščević, Grob 830 s nekropole na Relji u Zadru i problem datacije zdjelica Hayes 34 (Lamboglia 6), *Diadora* 15, 55–83.
- GLUŠČEVIĆ 1995:** Smiljan Gluščević, Staklene čaše s udubljenjima iz rimske luke u Zatonu, *Diadora* 16–17, 221–242.
- GLUŠČEVIĆ 2000:** Smiljan Gluščević, Roman glass in Zadar: Certain characteristic forms, u/in: *Annales du 14e congrès de l'AIHV*, Lochem, 182–189.
- GOETHERT-POLASCHEK 1977:** Karin Goethert-Polaschek, *Katalog der römischen Gläser des Rheinischen Landesmuseum Trier*, Trierer Grabungen und Forschungen 9, Trier.
- GREGL 1989:** Zoran Gregl, *Rimskodobna nekropola Zagreb-Stenjevec*, Katalozi Arheološkog muzeja u Zagrebu, sv. 3, Zagreb.
- GREGL 1997:** Zoran Gregl, *Rimske nekropole sjeverne Hrvatske – The Roman Cemeteries of Northern Croatia*, Exhibition catalogue, Zagreb.
- GREGL 2007:** Zoran Gregl, Rimskodobna nekropola Gornja Vas na Žumberku, *Vjesnik Arheološkog muzeja u Zagrebu* 40, 221–332.
- HARDEN 1936:** Donald B. Harden, *Roman Glass from Karanis*, University of Michigan Studies, Humanistic Series 41.
- HARDEN et al. 1988:** Donald B. Harden et al., *Glass der Caesaren*, Ausstellungskatalog, Milano.
- HAYES 1975:** John W. Hayes, *Roman and Pre-Roman Glass in the Royal Ontario Museum*, Toronto.
- ISINGS 1957:** Clasina Isings, *Roman Glass from Dated Finds*, *Archaeologica Traiectina* 2, Groningen-Djakarta.
- ISTENIČ 1999:** Janka Istenič, *Poetovio, zahodna grobišča I / Poetovio, the Western Cemeteries I*, Katalozi in monografije 32, Ljubljana.
- ISTENIČ 2000:** Janka Istenič, *Poetovio, zahodna grobišča II / Poetovio, the Western Cemeteries II*, Katalozi in monografije 33, Ljubljana.
- KIRIGIN 1980:** Branko Kirigin, Merkur bočice iz Arheološkog muzeja u Splitu, *Vjesnik za arheologiju i historiju dalmatinsku* 72, 61–65.
- KISIĆ 2000:** A. Kisić, *Antički brod u podmorju Mljeta*, katalog izložbe / exhibition catalogue, Dubrovnik.
- KOLŠEK 1977:** Vera Kolšek, *Vzhodni del antične nekropole v Šempetru*, Katalozi in monografije 14, Ljubljana.
- KUJUNDŽIĆ 1982:** Ziljka Kujundžić, *Poetovijske nekropole*, Katalozi in monografije 20, Ljubljana.
- LAZAR 1997:** Irena Lazar, Poznorimske najdbe iz Celja, *Arheološki vestnik* 48, 325–331.
- LAZAR 2003:** Irena Lazar, *Rimsko steklo Slovenije / The Roman Glass of Slovenia*, Opera Instituti Archaeologici Sloveniae 7, Ljubljana.
- LAZAR 2004:** Irena Lazar, Odsevi davnine – Antično steklo v Sloveniji / Spiegelunegn der Vorzeit – Antikes Glas in Slowenien, u/in: I. Lazar (ed.), *Rimljani – steklo, glina, kamen / Die Römer – Glas, Ton, Stein*, Ausstellungskatalog, Celje – Ptuj – Maribor, 11–81.
- LAZAR 2005A:** Irena Lazar, Fragment of the base of the bottle with the inscription SENTIA SECUNDA, *Bull. Instrumentum* 21, Montagnac, 41–42.
- LAZAR 2005B:** Irena Lazar, An oil lamp depicting a Roman Glass furnace – a new find from Slovenia, *Bull. Instrumentum* 22, Montagnac, 17–19.
- LAZAR 2006A:** Irena Lazar, The glass from a rubbish pit, u/in: Ljudmila Plesničar Gec et al., *Emonski forum / Emona forum*, *Annales Meditteranea*, Koper, 106–116.
- LAZAR 2006B:** Irena Lazar, Base marks on glass vessels found on the territory of modern Slovenia – Commentary and catalogue, u/in: D. Foy, M.-D. Nenna (eds.), *Corpus des signatures et marques sur verres antiques, vol. 2, AFAV, Aix-en-Provence, Lyon, 245–262*.
- LAZAR 2006C:** Irena Lazar, Base marks on glass vessels in Croatia: Catalogue, u/in: D. Foy, M.-D. Nenna (eds.), *Corpus des signatures et marques sur verres antiques, vol. 2, AFAV, Aix-en-Provence, Lyon, 273–282*.
- LAZAR 2006D:** Irena Lazar, Base marks on the glass vessels in Hungary: Catalogue, u/in: D. Foy, M.-D. Nenna (eds.), *Corpus des signatures et marques sur verres antiques, vol. 2, AFAV, Aix-en-Provence, Lyon, 263–272*.
- LAZAR 2006E:** Irena Lazar, Inscriptions on glass vessels craftsmen, workshops and trade routes, *Histria antiqua* 14, 115–124.
- LAZAR 2006F:** Irena Lazar, *Ilovica pri Vraskem*, Arheologija na avtocestah Slovenije, Katalozi 1, Ljubljana.
- LAZAR 2007:** Irena Lazar, The Roman Glass Bottle from Poetovio – a Souvenir from Alexandria? u/in: *Egypt and Austria IV*, Brno, 67–74.
- LAZAR 2008:** Irena Lazar, Steklo emonske nekropole pri gradbišču Slovenijales, *Annales Meditteranea*, Koper, in print.
- LAZAR & TOMANIČ JEVREMOV 2000:** Irena Lazar i Marjana Tomanič Jevremov, Dragoceni stekleni predmeti iz ptujskega groba 11/1978, *Arheološki vestnik* 51, 195–204.
- LECLANT 1973:** Jean Leclant, Glass from the Meroitic necropolis of Sedeinga (Sudanese Nubia), *Journal of Glass Studies* 15, 52–68.
- LIPOVAC VRKLJAN 2007:** Goranka Lipovac Vrkljan, *Ad turres – Crikvenica, keramičarska radionica Seksta Metilija Maksima*, Crikvenica.
- LJUBIĆ 1881:** Šime Ljubić, Arkeologičko izkapanje u Bakru, *Viestnik hrvatskoga arkeologičkoga društva*, IV/1, 1–9.
- LJUBIĆ 1882:** Šime Ljubić, Arkeologičko izkopavanje u Bakru, *Viestnik hrvatskoga arkeologičkoga društva*, IV/2, 48–54.
- LJUBIĆ 1882:** Šime Ljubić, Arkeologičko izkopavanje u Bakru, *Viestnik hrvatskoga arkeologičkoga društva*, IV/3, 66–67.
- MACCABRUNI 1999:** Claudia Maccabruni, I vetri di Albenga nella Liguria romana, u/in: B. Massabò (ed.), *Magiche trasparenze – I vetri dell' antica Albigaunum*, katalog izložbe / exhibition catalogue, Milano, 157–166.
- MACCABRUNI 2004:** Claudia Maccabruni, La ricerca sulla produzione vetraria antica in area norditalica, u/in: I. Lazar (ed.), *Drobc antičnega stekla – Fragments of Ancient Glass*, *Annales Meditteranea*, Koper, 2004, 25–42.
- MANDRUZZATO & MARCANTE 2005:** Luciana Mandruzzato, Alessandra Marcante, *Vetri antichi del Museo Archeologico Nazionale di Aquileia – Il vaselame di mensa*, *Corpus delle collezioni del vetro in Friuli Venezia Giulia* 2, Udine.
- MANDRUZZATO & MARCANTE 2007:** Luciana Mandruzzato, Alessandra Marcante, *Vetri antichi del Museo Archeologico Nazionale di Aquileia – Balsamari, olle e pissidi*, *Corpus delle collezioni del vetro in Friuli Venezia Giulia* 3, Udine.
- MAROCCHINO 1965:** Ivo Marocchino, Rimsko grobište u Bakru, *Vijesti muzealaca i konzervatora Hrvatske* 14/4, 109–111.
- MASSABÒ 1999:** Bruno Massabò (ed.), *Magiche trasparenze – I vetri dell' antica Albigaunum*, katalog izložbe / exhibition catalogue, Milano.
- MATIJAŠIĆ 1998:** Robert Matijašić, *Gospodarstvo antičke Istre*, Pula.
- MECONCELLI NOTARIANNI 1979:** Gioia Meconcelli Notarianni, *Vetri antichi nelle collezioni del Museo civico archeologico di Bologna*, *Cataloghi*, nuova serie 1, Bologna.
- MIKL CURK 1975:** Iva Mikl Curk, *La nécropole de Formin*, *Inventaria Archaeologica Jugoslavija* 19, Beograd.
- MORIN-JEAN 1913:** Morin Jean, *La verrerie en Gaule sous l'empire romain*, Paris.
- NEMETH EHRlich 1994:** Dorica Nemeth Ehrlich, Andautonija, rimsko urbano središte – Andautonia, a Roman urban centre, u/in: *Zagreb prije Zagreba / Zagreb before Zagreb*, exhibition catalogue, Zagreb.
- NENNA 2003:** Marie-Dominique Nenna, Verres gravés d'Égypte du 1er au Ve siècle ap. J.-C., u/in: D. Foy, M.-D. Nenna (eds.), *Échanges et commerce du verre dans le monde antique*, *Actes du colloque de l'AFAV, Monographies Instrumentum* 24, Montagnac, 359–376.
- NENNA 2006A:** Marie-Dominique Nenna, Marques conservées dans les musées français de provenance inconnue ou étrangère, u/in: D. Foy, M.-D. Nenna (eds.), *Corpus des signatures et marques sur verres antiques, vol. 1, AFAV, Aix-en-Provence, Lyon, 201–214*.

- NENNA 2006B:** Marie-Dominique Nenna, Marques sur verre découvertes au Proche et Moyen-Orient (Irak, Israël, Jordanie, Ligan et Syrie), u/in: D. Foy, M.-D. Nenna (eds.), *Corpus des signatures et marques sur verres antiques, vol. 2, AFAV, Aix-en-Provence, Lyon, 431–446.*
- NENNA 2007:** Marie-Dominique Nenna, Production et commerce du verres à l'époque impériale: nouvelles découvertes et problématiques, *Facta – A Journal of Roman Material Culture Studies* 1, 125–148.
- PAHIČ 1969:** Stanko Pahič, Antična gomila z grobnico v Miklavžu pri Mariboru, *Arheološki vestnik* 20, 35–114.
- PASQUALUCCI 1998:** Rita Pasqualucci, Contribui sulla collezione Gorga. Gli unguentarii bollati, u/in: Atti 2e giornate nazionali di studio AIHV (Milano 1996), Milano, 115–120.
- PETRU 1969:** Peter Petru, Rimski grobovi iz Dobove, Ribnice in Petrušnje vasi, *Razprave 1. razreda SAZU* 6, Ljubljana, 5–82.
- PETRU 1972:** Sonja Petru, *Emonske nekropole*, Katalogi in monografije 7, Ljubljana.
- PILEPIĆ 1881:** Franjo Pilepić, Odkriće rimskog groblja u Bakru, *Viestnik hrvatskoga arheološkoga društva*, III/1, 15–16.
- PLESNIČAR GEC 1972:** Ljudmila Plesničar Gec, *Severno emonsko grobišče*, Katalogi in monografije 8, Ljubljana.
- PLESNIČAR GEC 1977:** Ljudmila Plesničar Gec, *Keramika emonskih nekropol*, Dissertationes et monographiae 20, Ljubljana.
- PLESNIČAR GEC 1983:** Ljudmila Plesničar Gec, *Starokrščanski center v Emoni*, Katalogi in monografije 21, Ljubljana.
- PRICE 2006:** Jennifer Price, Mould-blown and impressed designs and names on vessels in Spain, u/in: D. Foy, M.-D. Nenna (eds.), *Corpus des signatures et marques sur verres antiques, vol. 2, AFAV, Aix-en-Provence, Lyon, 283–321.*
- RAVAGNAN 1994:** Giovanna Luisa Ravagnan, *Vetri antichi del Museo Vetrario di Murano*, Corpus CAVV 1, Venezia.
- RITTERLING 1912:** Elisabeth Ritterling, *Das frühromische Lager bei Hofheim im Taunus*, Annalen des Vereins für Nassauer Altertumskunde und Geschichtsforschung 40.
- ROTTLOFF 1999:** Andrea Rottloff, Römische Glasverarbeitung in Augusta Vindelicum – Augsburg, Bayerische Vorgeschichtsblätter 64, 168–193.
- ROTTLOFF 2006:** Andrea Rottloff, Bodenmarken auf halbformgeblasenen Gläsern aus Raetien, u/in: D. Foy, M.-D. Nenna (eds.), *Corpus des signatures et marques sur verres antiques, vol. 2, AFAV, Aix-en-Provence, Lyon, 145–186.*
- RÜTTI 1991:** Beat Rütli, *Die römischen Gläser aus Augst und Kaiseraugst*, Forschungen in Augst 13/1, 2.
- RÜTTI 2003:** Beat Rütli, Les verres peints du Haut Empire romain: centres de production et diffusion, u/in: D. Foy, M.-D. Nenna (eds.) *Echanges et commerce du verre dans le monde antique, Monographies Instrumentum* 24, Montagnac, 349–358.
- SABLEROLLES 2006:** Yvette Sablerolles, Marks on glass vessels from the Netherlands and Flanders (Belgium), u/in: D. Foy, M.-D. Nenna (eds.), *Corpus des signatures et marques sur verres antiques, vol. 2, AFAV, Aix-en-Provence, Lyon, 15–68.*
- SALDERN 1976:** Axel von Saldern, Glasrythona, u/in: T. E. Haevernick, A. von Saldern (eds.), *Festschrift für Waldemar Haberey*, Mainz, 121–126.
- SAMPAOLO 1986:** V. Sampaolo, Le pitture, u/in: O. Ferrari et al., *Le collezioni del Museo Nazionale di Napoli*, Roma, 124–173.
- SCATTOZZA HÖRICH 1986:** Lucia Amalia Scattozza Hörich, *I vetri romani di Ercolano*, Ministero per i beni culturali ed ambientali, Soprintendenza Archeologica di Pompei, Cataloghi 1, Roma.
- SEITTER 1991:** Verena Seitter, Bemerkungen zur Herstellung von formgeblasenen römischen Gläsern mit Bodenmarken, *Archäologisches Korrespondenzblatt* 21, 527–533.
- SLABE 1976:** Marijan Slabe, Antični grob iz Šahovca pri Dobrniču, *Arheološki vestnik* 26, 242–249.
- SOROKINA 1979:** Nina P. Sorokina, Ein Glass Pokal mit Iphigeniens Namen aus Pantikapeion, u / in: T. E. Haevernick, A. von Saldern (eds.), *Festschrift für Waldemar Haberey*, Mainz, 145–152.
- SOROKINA 1987:** Nina P. Sorokina, Glass Aryballoi (1st – 3rd Centuries A.D.) from the Northern Black Sea Region, *Journal of Glass Studies* 29, 40–46.
- SOROKINA 1993:** Nina P. Sorokina, Wo wurde der Amphoriskos aus Pantikapaion geblasen und bemalt?, u/in: *Annales de 12e Congrès de l'AIHV*, Amsterdam, 59–66.
- STARAC 2000:** Alka Starac, *Rimsko vladanje u Istriji i Liburniji II – Liburnija*, Monografije i katalogi 10/II, Arheološki muzej Istre, Pula.
- STERN 1994:** Eva Marianne Stern, *Early Glass of the Ancient World 1600 B.C.-A.D. 50*, Ernesto Wolf Collection, Ostfildern.
- STERN 1997:** Eva Marianne Stern, Neikais – A Woman Glass Blower of the First Century A.D., u/in: G. Erath, M. Lehner, G. Schwarz (eds.), *Komos, Festschrift für Thuri Lorenz zum 65. Geburtstag*, Wien, 129–132.
- STERN 2001:** Eva Marianne Stern, *Roman, Byzantine and Early Medieval Glass (10 BCE – 700 CE)*, E. Wolf Collection, Ostfildern.
- STERN 2005:** Eva Marianne Stern, À la recherche de la première canne à souffler, *Bulletin Instrumentum* 21/05, Montagnac, 15–18.
- STERN 2008:** Eva Marianne Stern, Glass production, u/in: J. P. Oleson (ed.) *The Oxford Handbook of Engineering and Technology in the Classical World*, Oxford, 520–547.
- STERNINI 1991:** Mara Sternini, *La verrierie romaine du Musée archéologique de Nîmes II*, Cahiers des Musées et Monuments de Nîmes 8, Nîmes.
- STERNINI 1993:** Mara Sternini, I vetri, u/in: W. V. Harris (ed.), *The inscribed economy. Production and distribution in the Roman empire in the light of instrumentum domesticum, JRA Suppl. Series* 6, Ann Arbor Michigan, 81–94.
- TABORELLI 1999:** Luigi Taborelli, Unguentari di vetro delle necropoli marchigiane: tipi di medie e grandi dimensioni, tra II e III secolo D.C., *Picus* 19, 267–298.
- TARPINI 2000:** Roberto Tarpini, La forma Isings 42a var. Limburg 1971: Aspetti morfologici-tecnologici e sua diffusione nell'Italia settentrionale, u / in: *Annales du 13e Congrès de l'AIHV*, Lochem, 95–98.
- TRASPARENZE 1998:** *Trasparenze imperiali, Vetri romani dalla Croazia*, Catalogo della mostra, Milano.
- TUŠEK 1985:** Ivan Tušek, Ptuj – Novogradnje, *Varstvo spomenikov* 27, 239–246.
- URLEB 1984:** Mehtilda Urleb. 1984, Antično grobišče v Cerknici, *Arheološki vestnik* 34, 298–346.
- VESSBERG 1952:** Otto Vessberg, *Roman Glass in Cyprus*, Opuscula Archaeologica 7.
- VESSBERG 1956:** Otto Vessberg. 1956, Glass: Typology – Chronology, u / in: O. Vessberg, A. Westholm, *The Swedish Cyprus Expedition*. Vol. IV, Part 3: *The Hellenistic and Roman Periods in Cyprus*, 128–175, 193–219.
- VIČIČ & SCHEIN 1987:** Boris Vičič, Tine Schein, Unec – antično grobišče, *Arheološki pregled* 1986, 164–165.
- WELKER 1974:** Edith Welker, *Die römischen Gläser von Nidda-Heddernheim*, Schriften des Frankfurter Museums für Vor- und Frühgeschichte 3, Frankfurt.
- WHITEHOUSE 1997:** David Whitehouse, *Roman Glass in The Corning Museum of Glass, Vol. One*, Corning, New York.
- WIEWEGH 2003:** Zoran Wiewegh, *Jugoistočna nekropola Siscije*, Gradski muzej Sisak, Sisak.
- ZAMPIERI 1998:** Girolamo Zampieri 1998, *Vetri antichi del Museo Civico Archeologico di Padova*, Corpus delle collezioni archeologiche del vetro nel Veneto (CCAVV) 3, Venezia.

Irena Lazar, Marina Gregl, Zoran Gregl

Katalog predmeta **Catalogue of Objects**

Legenda:

inv. br. inventarni broj
vis. visina
pr. r. promjer ruba
pr. t. promjer tijela
pr. dna promjer dna
Is oblik Isings 1957
var. varijanta
Dat. Datacija

Abbreviations:

Inv. no. inventory number
H. height
Dia. rim diameter of the rim
Dia. body diameter of the body
Dia. base diameter of the base
Is form from Ising 1957
Var. variant

STOLNO POSUĐE TABLEWARE

Tanjuri



1. Tanjur, inv. br. I 1859, t. I: 1.

Tanjur s vertikalnim rubom, plitak. Rub izvučen prema van, cjevasto savijen prema dolje. Dno ravno, na sredini blago uvučeno. Staklo kobaltno plavo.

vis: 2,6 cm
pr. r.: 18,3 cm
pr. dna: 16 cm

Iskopavanje: 1882. g.
Publicirano: Ljubić 1882, 49, B-9; Arte cultura, kat. 171.
Analogije: Gregl 1989, 22, t. 12: 2; Biaggio Simona 1991, tav. 1; Trasparenze 1998, 187, no. 183; Ravagnan 1994, 227, no. 456–460; Bonomi 1996, 191, no. 434–435; Buljević 2002, 211, br. 5–7; Mandruzato, Marcante 2005, 147, no. 311–313;
Dat.: sredina – druga pol. 1. st.

2. Tanjur, inv. br. I 1030, t. I: 2.

Tanjur s ravnim rubom, plitak. Dno ravno, s izvučenim stajaćim prstenom, staklo dekolirano.

vis.: 1,2 cm
pr. r.: 13 cm
pr. dna: 5,9 cm

Iskopavanje: 1882. g.
Nije publicirano.
Analogije: Rütli 1991, AR 74; Massabò 1999, 261.
Dat.: sredina – druga pol. 1. st.

3. Tanjur, inv. br. I 1027, t. I: 3.

Tanjur s ravnim vertikalnim rubom. Dno s izvučenim visokim stajaćim prstenom.

vis.: 4,8 cm
pr. r.: 21,5 cm
pr. dna: 10,2 cm

Iskopavanje: 1882. g.
Publicirano: Ljubić 1882, 49/B, br. 11; Damevski 1976, 65, t. 10: 5.
Analogije: Is 47; Lazar 2003, 64, forma 1.2.1., Whitehouse 1997, 70, no. 82.
Dat.: druga pol. 1. – početak 2. st.

Plates

1. Plate, inv. no. I 1859, pl. I: 1.

A plate with vertical walls, shallow. The rim tubular. The base flat, slightly concave in the middle. Cobalt blue glass.

H: 2.6 cm
Dia. rim: 18.3 cm
Dia. base: 16 cm

Excavation: 1882.
Published: Ljubić 1882, 49, B-9; Arte cultura 1993, cat. no. 171
Analogies: Gregl 1989, 22, t. 12: 2; Biaggio Simona 1991, tav. 1; Trasparenze 1998, 187, no. 183; Ravagnan 1994, 227, no. 456–460; Bonomi 1996, 191, no. 434–435; Buljević 2002, 211, br. 5–7; Mandruzato, Marcante 2005, 147, no. 311–313;
Date: Middle to second half of the 1st cent.

2. Plate, inv. no. I 1030, pl. I: 2.

A shallow plate with a straight rim. The base flat, with a tubular base ring. The glass de-coloured.

H: 1.2 cm
Dia. rim: 13 cm
Dia. base: 5.9 cm

Excavation: 1882.
Unpublished.
Analogies: Rütli 1991, AR 74; Massabò 1999, 261.
Date: Middle – second half of the 1st cent.

3. Plate, inv. no. I 1027, pl. I: 3.

Plate with straight vertical walls and rim. The base with a high tubular base ring.

H: 4.8 cm
Dia. rim: 21.5 cm
Dia. base: 10.2 cm

Excavation: 1882.
Published: Ljubić 1882, 49/B, no. 11; Damevski 1976, 65, pl. 10: 5.
Analogies: Is 47; Lazar 2003, 64, form 1.2.1, Whitehouse 1997, 70, no. 82.
Date: Second half of the 1st cent. – beginning of the 2nd cent.

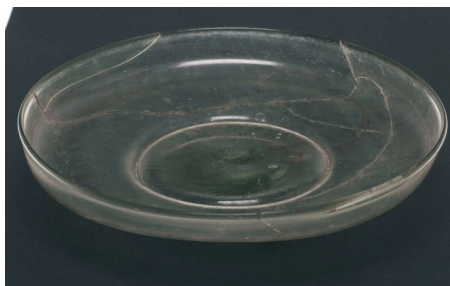
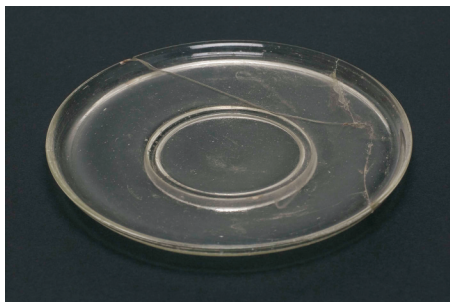

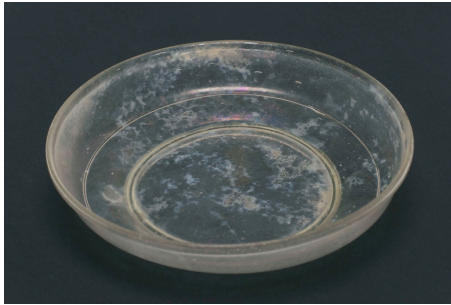

4. Tanjur, inv. br. I 1021, t. I: 4.

Tanjur, dublji. Rub ravno završava, zadebljan s vanjske strane. Na stijenci s vanjske strane nataljena staklena nit. Dno ravno, s izvučenim stajaćim prstenom.

vis.: 3,8 cm
pr. r.: 17 cm
pr. dna: 10 cm

Iskopavanje: 1882. g.
Publicirano: Ljubić 1882, 49, B-12.
Analogije: Lazar 2003, 65, forma 1.2.2.
Dat.: druga pol. 1. – početak 2. st.

4. Plate, inv. no. I 1021, pl. I: 4.

A deep plate. The rim ends straight, thickened on the outer side. Applied glass trail on the outside of the wall. The base flat, with a tubular base ring.

H: 3.8 cm
Dia. rim: 17 cm
Dia. base: 10 cm

Excavation: 1882.
Published: Ljubić 1882, 49, B-12.
Analogies: Lazar 2003, 65, form 1.2.2.
Date: Second half of the 1st cent. – beginning of the 2nd cent.



5. Tanjur, inv. br. I 1110, t. I: 5.

Tanjur dublji, rub cjevasto savijen prema van i prema dolje. Dno uvučeno, sa dva izvučena stajaća prstena, vanjski deblji, unutarnji tanji.

vis: 4,1 cm
pr. r.: 16,5 cm
pr. dna: 13,6 cm

Iskopavanje: 1882. g.
Publicirano: Ljubić 1882, 49, B-13; Damevski 1976, t. 11: 5.
Analogije: Is 48; Trasparenze 1998, 186, no. 177, 179; Whitehouse 1997, 68, no. 77, 78; Mandruzzato, Marcante 2005, 110, no. 317.
Dat.: druga pol. 1. st.

5. Plate, inv. no. I 1110, pl. I: 5.

A deep plate with the tubular rim. The base concave, with a double tubular base ring, the outside thicker, the inner one thinner.

H: 4.1 cm
Dia. rim: 16.5 cm
Dia. base: 13.6 cm

Excavation: 1882.
Published: Ljubić 1882, 49, B-13; Damevski 1976, pl. 11: 5.
Analogies: Is 48; Trasparenze 1998, 186, no. 177, 179; Whitehouse 1997, 68, no. 77, 78; Mandruzzato, Marcante 2005, 110, no. 317.
Date: Second half of the 1st cent.

6. Tanjur, ulomak, inv. br. I 1341a, t. I: 6.

Tanjur s vodoravno jače razgrnutim rubom. Dno nije sačuvano.

vis.: 2,1 cm
pr. r.: 17 cm

Iskopavanje: 1882. g.
Publicirano: Ljubić 1882, 49, B-8.
Analogije: Is 42b; Biaggio Simona 1991, tav. 2: 139.2.016 in 032.
Dat.: druga pol. 1. – prva pol. 2. st.

6. Plate, fragment, inv. no. I 1341a, pl. I: 6.

A plate with a horizontal strongly everted rim. The base is not preserved.

H: 2.1 cm
Dia. rim: 17 cm

Excavation: 1882.
Published: Ljubić 1882, 49, B-8.
Analogies: Is 42b; Biaggio Simona 1991, pl. 2: 139.2.016 and 032.
Date: Second half of the 1st cent. – first half of the 2nd cent.

7. Tanjur, ulomak, inv. br. I 1341b, t. I: 7.

Tanjur s vodoravno jače razgrnutim rubom. Dno nije sačuvano.

vis.: 1,8 cm
pr. r.: 17 cm

Iskopavanje: 1882. g.
Publicirano: Ljubić 1882, 49, B-8.

7. Plate, fragment, inv. no. I 1341b, pl. I: 7.

A plate with a horizontal strongly everted rim. The base is not preserved.

H: 1.8 cm
Dia. rim: 17 cm

Excavation: 1882.
Published: Ljubić 1882, 49, B-8.

Analogije: Is 42b; Biaggio Simona 1991, tav. 2: 139.2.016 in 032.

Dat.: druga pol. 1. – prva pol. 2. st.

Analogies: Is 42b; Biaggio Simona 1991, pl. 2: 139.2.016 and 032.

Date: Second half of the 1st cent. – first half of the 2nd cent.



8. Tanjur, inv. br. I 1342, t. 2: 1.

Ulomci plitkog tanjura. Rub vodoravno razgrnut prema van, ukrašen brušenim urezima – zrno riže. Dno s izvučenim stajaćim prstenom, malo uvučeno.

vis.: 2,8 cm
pr. r.: 18 cm
pr. dna: 9,8 cm

Iskopavanje: 1882. g.

Nije publicirano.

Analogije: var. Is 42a; Lazar 2003, 73, varijanta forme 2.4.2. – niska; Tarpini 2000, 95.

Dat.: druga pol. 1. – 2. st.

8. Plate, inv. no. I 1342, pl. 2: 1.

Fragments of a shallow plate. The rim horizontally splayed outwards, decorated with ground incisions like rice grains. The slightly concave base with a tubular base ring.

H: 2.8 cm
Dia. rim: 18 cm
Dia. base: 9.8 cm

Excavation: 1882.

Unpublished.

Analogies: Var. Is 42a; Lazar 2003, 73, form 2.4.2 – low; Tarpini 2000, 95.

Date: Second half of the 1st cent. – 2nd cent.

9. Tanjur, ulomci, inv. br. I 1340/4, t. 2: 2.

Ulomci plitkog tanjura. Rub vodoravno razgrnut prema van, ukrašen brušenim urezima – zrno riže. Dno nije sačuvano.

vis.: 1,8 cm
pr. r.: 16,6 cm

Iskopavanje: 1882. g.

Nije publicirano.

Analogije: var. Is 42a; Lazar 2003, 73, varijanta forme 2.4.2. – niska; Tarpini 2000, 95.

Dat.: druga pol. 1. – 2. st.

9. Plate, fragments, inv. no. I 1340/4, pl. 2: 2.

Fragments of a shallow plate. The rim horizontally splayed outwards, decorated with ground incisions like rice grains. The base was not preserved.

H: 1.8 cm
Dia. rim: 16.6 cm

Excavation: 1882.

Unpublished.

Analogies: Var. Is 42a; Lazar 2003, 73, form 2.4.2 – low; Tarpini 2000, 95.

Date: Second half of the 1st cent. – 2nd cent.

10. Tanjur, ulomci, inv. br. I 1340-2c

Ulomci ruba tanjura. S donje strane rub je jako profiliran.

pr. r.: 14,3 cm

Iskopavanje: 1882. g.

Nije publicirano.

Analogije: Is 42b

Dat.: druga pol. 1. – prva pol. 2. st.

10. Plate, fragments, inv. no. I 1340-2c

Fragments of the rim of a plate. The rim with ridge on the underside.

Dia. rim: 14.3 cm

Excavation: 1882.

Unpublished.

Analogies: Is 42b.

Date: Second half of the 1st cent. – first half of the 2nd cent.



11. Tanjur, inv. br. I 1028, t. 2: 3.

Tanjur s jače vodoravno razgrnutim rubom, s donje strane profiliran. Dno s izvučenim stajaćim prstenom. Staklo dekolirano.

vis.: 2,7 cm
pr. r.: 16 cm
pr. dna: 8,5 cm

Iskopavanje: 1882. g.
Publicirano: Ljubić 49, br. 6.
Analogije: Is 42b
Dat.: druga pol. 1. – prva pol. 2. st.

11. Plate, inv. no. I 1028, pl. 2: 3.

A plate with a horizontal strongly everted rim, with ridge on the underside. The base with a tubular base ring. Decoloured glass.

H: 2.7 cm
Dia. rim: 16 cm
Dia. base: 8.5 cm

Excavation: 1882.
Published: Ljubić 49, no. 6.
Analogies: Is 42b.
Date: Second half of the 1st cent. – first half of the 2nd cent.

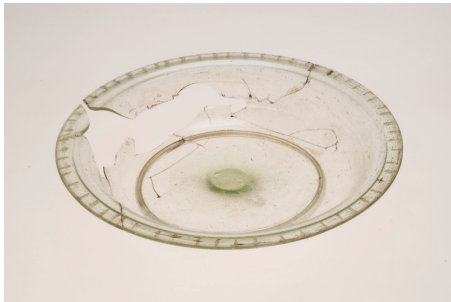

12. Tanjur, inv. br. I 1108, t. 2: 4.

Tanjur sa široko razgrnutim rubom. Rub je s donje strane blago profiliran, a s gornje strane ukrašen brušenim urezima – zrno riže. Dno s izvučenim stajaćim prstenom, u sredini malo uvučeno.

vis.: 2,3 cm
pr. r.: 17 cm
pr. dna: 9,5 cm

Iskopavanje: 1882. g.
Publicirano: Ljubić 1882, 49, B-4;
Damevski 1976, t. 11: 6.
Analogije: Is 42a; Mandruzzato, Marcante 2005, 147, no. 318; Tarpini 2000, 95.
Dat.: druga pol. 1. – 2. st.

12. Plate, inv. no. I 1108, pl. 2: 4.

A plate with a rim horizontally splayed outwards. The rim with ridge on the underside, and the upper side decorated with ground incisions like rice grains. The base has a tubular base ring, slightly concave in the centre.

H: 2.3 cm
Dia. rim: 17 cm
Dia. base: 9.5 cm

Excavation: 1882.
Published: Ljubić 1882, 49, B-4;
Damevski 1976, pl. 11: 6.
Analogies: Is 42a; Mandruzzato, Marcante 2005, 147, no. 318; Tarpini 2000, 95.
Date: Second half of the 1st cent. – 2nd cent.



13. Tanjur, inv. br. I 1029, t. 3: 1.

Tanjur manjih dimenzija. Rub široko vodoravno razgrnut, s donje strane ukras nataljene staklene niti. Dno sa izvučenim visokim stajaćim prstenom. Staklo dekolirano.

vis.: 3,4 cm
pr. r.: 15,1 cm
pr. dna: 7,4 cm

Iskopavanje: 1882. g.
Publicirano: Ljubić 1882, 49, B-7.
Analogije: var. Is 45; Biaggio Simona 1991, tav. 2: 139.2.016 in 032.
Dat.: druga pol. 1. – 2. st.

13. Plate, inv. no. I 1029, pl. 3: 1.

A small plate. The rim widely splayed horizontally, with a decoration of applied glass trail. The base with a high tubular base ring. Decoloured glass.

H: 3.4 cm
Dia. rim: 15.1 cm
Dia. base: 7.4 cm

Excavation: 1882.
Published: Ljubić 1882, 49, B-7.
Analogies: Var. Is 45; Biaggio Simona 1991, pl. 2: 139.2.016 and 032.
Date: Second half of the 1st cent. – 2nd cent.



14. Tanjur, inv. br. I 1109, t. 3: 2.

Tanjur sa široko vodoravno razgrnutim rubom, cjevasto savijen prema dolje. S gornje strane aplicirane dvije plastične narebrne trake, podebljane u sredini. Dno s izvučenim stajaćim prstenom, uvučeno prema unutra.

vis.: 4 cm
pr. r.: 21 cm
pr. dna: 9 cm

14. Plate, inv. no. I 1109, pl. 3: 2.

A plate with a tubular, wide splayed rim. Two bands with relief ribbing, thickened in the center, were applied to the upper side. The base, concave in the centre, with a tubular base ring.

H: 4 cm
Dia. rim: 21 cm
Dia. base: 9 cm

Iskopavanje: 1882. g.
Publicirano: Ljubić 1882, 49, B-2; Damevski 1976, t. 11: 7.
Analogije: Is 43; Lazar 2003, 67, forma 1.3.2.; Mandruzzato, Marcante 2005, 147, no. 309; Trasprenze 1998, 186, no. 178; Ravagnan 1994, 230, no. 464–465.
Dat.: kraj 1. – prva pol. 2. st.

Excavation: 1882.
Published: Ljubić 1882, 49, B-2; Damevski 1976, pl. 11: 7.
Analogies: Is 43; Lazar 2003, 67, form 1.3.2.; Mandruzzato, Marcante 2005, 147, no. 309; Trasprenze 1998, 186, no. 178; Ravagnan 1994, 230, nos. 464–465.
Date: End of the 1st cent. – first half of the 2nd cent.

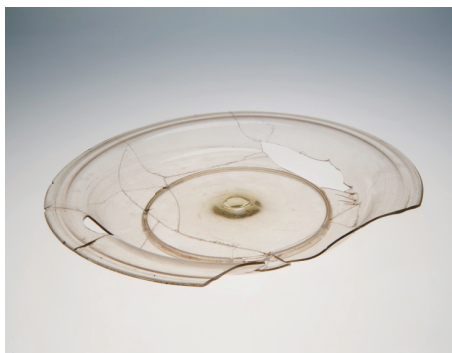

15. Tanjur, inv. br. I 1105, t. 3: 3.

Tanjur većih dimenzija. Rub široko razgrnut prema van, s donje strane profiliran. Dno s izvučenim stajaćim prstenom.

vis.: 4,2 cm
pr. r.: 30,4 cm
pr. dna: 16,5 cm

Iskopavanje: 1882. g.
Publicirano: Ljubić 1882, 49, B-1.
Analogije: var. Is 43.
Dat.: 2. st.

15. Plate, inv. no. I 1105, pl. 3: 3.

A large plate. The rim broad and splayed outwards, with ridge on the underside. The base with a tubular base ring.

H: 4.2 cm
Dia. rim: 30.4 cm
Dia. base: 16.5 cm

Excavation: 1882.
Published: Ljubić 1882, 49, B-1.
Analogies: Var. Is 43.
Date: 2nd cent.

16. Tanjur, ulomak, inv. br. I 2022

Ulomak tanjura s ravnim rubom, cjevasto savijen prema dolje.

pr. r.: 18 cm

Nema podataka o iskopavanju.
Nije publicirano.
Dat.: 1. st.

16. Plate, fragment, inv. no. I 2022

A fragment of a plate with a straight wall and a tubular rim.

Dia. rim: 18 cm

No data about excavation.
Unpublished.
Date: 1st cent.

Zdjelice

I. Zdjelica, inv. br. I 1014/I, t. 4: 1.

Zdjelica s razgrnutim rubom, djelomično visi prema dolje zbog loše izrade, tijelo konusno. Dno s izvučenim stajaćim prstenom, u sredini uvučeno.

vis.: 3,5 cm
pr. r.: 7,6 cm
pr. dna: 5,2 cm

Iskopavanje: 1882. g.
Publicirano: Ljubić 1882, 50, D-3; Damevski 1976, 63, t. 1: 2.
Analogije: Is 41b; Lazar 2003, 72, forma 2.4.1.; Biaggio Simona 1991, tav. 5: 139.1.024–176.4.044; Mandruzzato, Marcante 2005, 140, no. 224; Whitehouse 1997, 102, no. 151; Ravagnan 1994, 188, no. 371–374; Trasprenze 1998, 176, no. 163, 165, 166.
Dat.: druga pol. 1. – početak 2. st.



Bowls

I. Bowl, inv. no. I 1014/I, pl. 4: 1.

A bowl with an everted rim, partly hanging down because of poor workmanship, conical body. The base concave in the centre with a tubular base ring.

H: 3.5 cm
Dia. rim: 7.6 cm
Dia. base: 5.2 cm

Excavation: 1882.
Published: Ljubić 1882, 50, D-3; Damevski 1976, 63, pl. 1: 2.
Analogies: Is 41b; Lazar 2003, 72, form 2.4.1.; Biaggio Simona 1991, pl. 5: 139.1.024–176.4.044; Mandruzzato, Marcante 2005, 140, no. 224; Whitehouse 1997, 102, no. 151; Ravagnan 1994, 188, no. 371–374; Trasprenze 1998, 176, no. 163, 165, 166.
Date: Second half of the 1st cent. – beginning of the 2nd cent.



**2. Zdjelica,
inv. br. I 1014/2, t. 4: 2.**

Zdjelica s razgrnutim rubom, djelomično visi prema dolje zbog loše izrade, tijelo konusno. Dno s izvučenim stajaćim prstenom, u sredini uvučeno.

vis.: 4 cm
pr. r.: 7,8 cm
pr. dna: 4,6 cm

Iskopavanje: 1882. g.
Publicirano: Ljubić 1882, 50, D-3; Damevski 1976, 63, t. 1: 2.
Analogije: Is 41b; Lazar 2003, 72, forma 2.4.1.; Biaggio Simona 1991, tav. 5: 139. 1.024–176.4.044; Mandruzzoato, Marcante 2005, 140, no. 224; Whitehouse 1997, 102, no. 151; Ravagnan 1994, 188, no. 371–374; Trasprenze 1998, 176, no. 163, 165, 166.
Dat.: druga pol. 1. – početak 2. st.

**2. Bowl,
inv. no. I 1014/2, pl. 4: 2.**

A bowl with an everted rim, partly hanging down because of poor workmanship, conical body. The base concave in the centre with a tubular base ring.

H: 4 cm
Dia. rim: 7.8 cm
Dia. base: 4.6 cm

Excavation: 1882.
Published: Ljubić 1882, 50, D-3; Damevski 1976, 63, pl. 1: 2.
Analogies: Is 41b; Lazar 2003, 72, form 2.4.1.; Biaggio Simona 1991, pl. 5: 139.1. 024–176.4.044; Mandruzzoato, Marcante 2005, 140, no. 224; Whitehouse 1997, 102, no. 151; Ravagnan 1994, 188, no. 371–374; Trasprenze 1998, 176, no. 163, 165, 166.
Date: Second half of the 1st cent. – beginning of the 2nd cent.



3. Zdjelica, inv. br. I 1015, t. 4: 3.

Zdjelica s razgrnutim rubom, tijelo konusno. Dno s izvučenim stajaćim prstenom. Visina posude nejednaka zbog loše izrade. Staklo jantarno smeđe boje.

vis.: 4,6 cm
pr. r.: 7,6 cm
pr. dna: 4,3 cm

Iskopavanje: 1882. g.
Publicirano: Ljubić 1882, 50, D-2.
Analogije: Is 41b; Lazar 2003, 72, forma 2.4.1.; Biaggio Simona 1991, tav. 5: 139. 1.024–176.4.044; Mandruzzoato, Marcante 2005, 140, no. 224; Whitehouse 1997, 102, no. 151; Ravagnan 1994, 188, no. 371–374; Trasprenze 1998, 176, no. 163, 165, 166.
Dat.: druga pol. 1. – početak 2. st.

3. Bowl, inv. no. I 1015, pl. 4: 3.

A bowl with an everted rim and conical body. The base with a tubular base ring. The height of the vessel unequal because of poor workmanship. Amber-brown glass.

H: 4.6 cm
Dia. rim: 7.6 cm
Dia. base: 4.3 cm

Excavation: 1882.
Published: Ljubić 1882, 50, D-2.
Analogies: Is 41b; Lazar 2003, 72, form 2.4.1.; Biaggio Simona 1991, pl. 5: 139.1. 024–176.4.044; Mandruzzoato, Marcante 2005, 140, no. 224; Whitehouse 1997, 102, no. 151; Ravagnan 1994, 188, no. 371–374; Trasprenze 1998, 176, no. 163, 165, 166.
Date: Second half of the 1st cent. – beginning of the 2nd cent.



4. Zdjelica, inv. br. I 1016, t. 4: 4.

Zdjelica s razgrnutim rubom, tijelo konusno. Dno u sredini uvučeno, s izvučenim stajaćim prstenom. Na stijenci veći mjehurići a i slabo izradena prstenasta noga. Staklo tamno plave boje.

vis.: 5,0 cm
pr. r.: 11,4 cm
pr. dna: 7,3 cm

Iskopavanje: 1882. g.
Publicirano: Ljubić 1882, 50, D-1.
Analogije: Is 41b; Lazar 2003, 72, forma 2.4.1.; Biaggio Simona 1991, tav. 5:

4. Bowl, inv. no. I 1016, pl. 4: 4.

A bowl with an everted rim and conical body. The base concave in the centre, with a tubular base ring. Large bubbles in the walls and a poorly formed base ring. Dark blue glass.

H: 5.0 cm
Dia. rim: 11.4 cm
Dia. base: 7.3 cm

Excavation: 1882.
Published: Ljubić 1882, 50, D-1.
Analogies: Is 41b; Lazar 2003, 72, form 2.4.1.; Biaggio Simona 1991, pl. 5:

139.1.024–176.4.044; Mandruzzato, Marcante 2005, 140, no. 224; Whitehouse 1997, 102, no. 151; Ravagnan 1994, 188, no. 371–374; Bonomi 1996, 162, no. 365; Trasprenze 1998, 176, no. 163, 165, 166.

Dat.: druga pol. 1. – početak 2. st.



5. Zdjelica, inv. br. I 1017, t. 4: 5.

Zdjelica s vodoravno razgrnutim rubom, tijelo polukružno. Dno s izvučenim stajaćim prstenom, u sredini uvučeno.

vis.: 4,7 cm
pr. r.: 12,7 cm
pr. dna: 6,3 cm

Iskopavanje: 1882. g.

Publicirano: Ljubić 1882, 48, A-6.

Analogije: Is 42; Lazar 2003, 73, forma 2.4.2.; Biaggio Simona 1991, tav. 6; Mandruzzato, Marcante 2005, 140, no. 226; Ravagnan 1994, 194, no. 387–388; Bonomi 1996, 162, no. 366–367; Trasprenze 1998, 176, no. 164.

Dat.: druga pol. 1 st.

139.1.024–176.4.044; Mandruzzato, Marcante 2005, 140, no. 224; Whitehouse 1997, 102, no. 151; Ravagnan 1994, 188, no. 371–374; Bonomi 1996, 162, no. 365; Trasprenze 1998, 176, no. 163, 165, 166. Date: Second half of the 1st cent. – beginning of the 2nd cent.

5. Bowl, inv. no. I 1017, pl. 4: 5.

A bowl with an out-turned rim and hemispherical body. The base concave in the centre, with a tubular base ring.

H: 4.7 cm
Dia. rim: 12.7 cm
Dia. base: 6.3 cm

Excavation: 1882.

Published: Ljubić 1882, 48, A-6.

Analogies: Isings 42; Lazar 2003, 73, form 2.4.2.; Biaggio Simona 1991, pl. 6; Mandruzzato, Marcante 2005, 140, no. 226; Ravagnan 1994, 194, no. 387–388; Bonomi 1996, 162, no. 366–367; Trasprenze 1998, 176, no. 164.

Date: Second half of the 1st cent.



6. Zdjelica, inv. br. I 1018, t. 4: 6.

Zdjelica s vodoravno razgrnutim rubom s dvije plastične narebrene trake na nje-mu, tijelo polukružno. Dno s izvučenim stajaćim prstenom.

vis.: 4 cm
pr. r.: 13 cm
pr. dna: 6,4 cm

Iskopavanje: 1882. g.

Publicirano: Ljubić 1882, 48, A-7; Damevski 1976, 63, t. 2: 5.

Analogije: Is 43; Lazar 2003, 74, forma 2.4.3.; Biaggio Simona 1991, tav. 6, 113. 1.001; 134.2.072; Whitehouse 1997, 75, no. 93; Ravagnan 1994, 194, no. 389.

Dat.: 2. st.

6. Bowl, inv. no. I 1018, pl. 4: 6.

A bowl with a horizontally everted rim with two ribbed applied bands, and a hemispherical body. The base with a tubular base ring.

H: 4 cm
Dia. rim: 13 cm
Dia. base: 6.4 cm

Excavation: 1882.

Published: Ljubić 1882, 48, A-7; Damevski 1976, 63, pl. 2: 5.

Analogies: Isings 43; Lazar 2003, 74, form 2.4.3.; Biaggio Simona 1991, pl. 6, 113.1.001; 134.2.072; Whitehouse 1997, 75, no. 93; Ravagnan 1994, 194, no. 389.

Date: 2nd cent.



7. Zdjelica, inv. br. I 1020, t. 4: 7.

Zdjelica s vodoravno razgrnutim rubom, s donje strane profiliran i na gornjoj strani ukrašen brušenim urezima – zrno riže.

Dno s izvučenim stajaćim prstenom, malo uvučeno.

vis.: 5,6 cm
pr. r.: 15,6 cm
pr. dna: 6,5 cm

Iskopavanje: 1882. g.

Publicirano: Damevski 1976, 63, t. 2: 1.

Analogije: Is 42a; Lazar 2003, 73, forma 2.4.2.; Rützi 1991, AR 83; Tarpini 2000, 97.

Dat.: 2. st.

7. Bowl, inv. no. I 1020, pl. 4: 7.

A bowl with a horizontally everted rim, the ridge on underside and the upper side decorated with ground incisions like rice grains. The slightly concave base with a tubular base ring.

H: 5.6 cm
Dia. rim: 15.6 cm
Dia. base: 6.5 cm

Excavation: 1882.

Publicirano: Damevski 1976, 63, pl. 2: 1.

Analogies: Is 42a; Lazar 2003, 73, form 2.4.2.; Rützi 1991, AR 83; Tarpini 2000, 97.

Date: 2nd cent.

**8. Zdjela, inv. br. I 1812, t. 4: 8.**

Zdjela s razgrnutim rubom, s donje strane profiliranim. Dno s izvučenim stajaćim prstenom, blago uvučeno.

vis.: 5,1 cm
pr. r.: 15,3 cm
pr. dna: 7,3 cm

Iskopavanje: 1882. g.
Publicirano: Ljubić 1882, 48, A-1.
Analogije: Is 42a; Lazar 2003, 73, forma 2.4.2.; Rütli 1991, AR 83; Tarpini 2000, 97.
Dat.: 2. st.

8. Bowl, inv. no. I 1812, pl. 4: 8.

A bowl with an everted rim, the ridge on underside. The slightly concave base with a tubular base ring.

H: 5.1 cm
Dia. rim: 15.3 cm
Dia. base: 7.3 cm

Excavation: 1882.
Published: Ljubić 1882, 48, A-1.
Analogies: Is 42a; Lazar 2003, 73, form 2.4.2.; AR 83; Tarpini 2000, 97.
Date: 2nd cent.

**9. Zdjelica, ulomci, inv. br. I 1340-3 a, t. 4: 9.**

Ulomci ruba zdjelice. S donje strane rub je profiliran.

pr. r.: 21,2 cm

Iskopavanje: 1882. g.
Nije publicirano.
Analogije: Is 42a; Lazar 2003, 73, forma 2.4.2.; Rütli 1991, AR 83; Tarpini 2000, 97.
Dat.: 2. st.

9. Bowl, fragments, inv. no. I 1340-3 a, pl. 4: 9.

Fragments of the rim of a bowl. The rim with ridge on underside.

Dia. rim: 21.2 cm

Excavation: 1882.
Unpublished.
Analogies: Is 42a; Lazar 2003, 73, form 2.4.2.; AR 83; Tarpini 2000, 97.
Date: 2nd cent.

10. Zdjelica, ulomci, inv. br. I 1340-1 b, t. 4: 10.

Ulomci ruba zdjelice. Sa donje strane je rub jako profiliran.

pr. r.: 14,8 cm

Iskopavanje: 1882. g.
Nije publicirano.
Analogije: Is 42a; Lazar 2003, 73, forma 2.4.2.; Rütli 1991, AR 83; Tarpini 2000, 97.
Dat.: 2. st.

10. Bowl, fragments, inv. no. I 1340-1 b, pl. 4: 10.

Fragments of the rim of a bowl. The rim with ridge on underside.

Dia. rim: 14.8 cm

Excavation: 1882.
Unpublished.
Analogies: Is 42a; Lazar 2003, 73, form 2.4.2.; AR 83; Tarpini 2000, 97.
Date: 2nd cent.

**11. Zdjela, inv. br. I 1343, t. 5: 1.**

Zdjela sa široko razgrnutim rubom prema van i na dolje, ispod ruba na stijenki nalijepljena staklena nit. Dno s izvučenim visokim stajaćim prstenom – nogom, na sredini uvučeno.

vis.: 7,5 cm
pr. r.: 19,4 cm
pr. dna: 10 cm

Iskopavanje: 1882. g.
Publicirano: Ljubić 1882, 48, A-2.
Analogije: Is 87; Rütli 1991, AR 79; Massabò 1999, tav. 12: 5; Vessberg 1952, tav. II. 12–14.
Dat.: druga pol. 2. – 3. st.

11. Bowl, inv. no. I 1343, pl. 5: 1.

A bowl with a rim widely everted outwards and with overhanging edge, below the rim glass trail applied to the wall. The base concave in the centre, with a high tubular base ring – foot.

H: 7.5 cm
Dia. rim: 19.4 cm
Dia. base: 10 cm

Excavation: 1882.
Published: Ljubić 1882, 48, A-2.
Analogies: Is 87; Rütli 1991, AR 79; Massabò 1999, pl. 12: 5; Vessberg 1952, pl. II. 12–14.
Date: Second half of the 2nd cent. – 3rd cent.



12. Zdjela, inv. br. I 1104, t. 5: 2.

Zdjela većih dimenzija. Rub razgrnut prema van i na dolje, s donje strane nalijepljena staklena nit. Dno sa izvučenim visokim stajaćim prstenom – nogom. Staklo dekolorirano.

vis.: 8 cm
pr. r.: 29,4 cm
pr. dna: 15,2 cm

Iskopavanje: 1882. g.
Publicirano: Ljubić 1882, 48, br. 5.
Analogije: Is 87; Massabò 1999, tav. 12: 5; Vessberg 1952, tav. II. 12–14.
Dat.: druga pol. 2. – 3. st.

12. Bowl, inv. no. I 1104, pl. 5: 2.

A large bowl. The rim everted outwards and with overhanging edge, with glass trail applied to the lower side. The base with a tubular base ring – foot. The glass decoloured.

H: 8 cm
Dia. rim: 29.4 cm
Dia. base: 15.2 cm

Excavation: 1882.
Published: Ljubić 1882, 48, no. 5.
Analogies: Is 87; Massabò 1999, pl. 12: 5; Vessberg 1952, pl. II. 12–14.
Date: Second half of the 2nd cent. – 3rd cent.



13. Zdjela, inv. br. I 1086, t. 5: 3.

Plitka zdjela s ravno odrezanim rubom, blago izvučenim prema van. Na stijenki horizontalna urezana linija i na dnu traka s urezima veličine zrna riže ograničena s po dvije urezane linije. Urezani ukras prikazuje tri velike ribe ili delfina (?) i riblju glavu. U središnjem medaljonu muško poprsje.

vis.: 4,2 cm
pr. r.: 19 cm

Iskopavanje: 1882. g.
Publicirano: Trasparenze 1998, kat. 187; Damevski 1976, 86, t. 14: 1.
Analogije: Stern, 2001, 156, no. 56.
Dat.: kraj 2. st.

13. Bowl, inv. no. I 1086, pl. 5: 3.

A shallow bowl with a flat cut rim, slightly everted. The walls have a horizontally wheel-cut line and at the bottom a wheel-cut band containing ground incisions in the size of a rice grain between two incised lines. The grooved and incised decoration depicts three large fish (or dolphins?) and a fish head, with fish heads etched in the base. In the central medallion a male figure.

H: 4.2 cm
Dia. rim: 19 cm

Excavation: 1882.
Published: Trasparenze 1998, cat. 187; Damevski 1976, 86, pl. 14: 1.
Analogies: Stern, 2001, 156, no. 56.
Date: End of the 2nd cent.

Čaše



I. Čaša, inv. br. I 1022, t. 6: 1.

Čaša s naborima, rub ravno odrezan, u profilu stepeničast, tijelo sa šest udubljenja. Dno ravno, djelomice uvučeno u sredini.

vis.: 9 cm
pr. r.: 6,5 cm
pr. dna: 3,6 cm

Iskopavanje: 1882. g.
Publicirano: Ljubić 1882, 49, C-1.
Analogije: Is 32; Biaggio Simona 1991, tav. 10: 139.1.019; Ravagnan 1994, 129, no. 242; Whitehouse 1997, 112, no. 171.
Dat.: druga pol. 1. – početak 3. st.

Beakers

I. Beaker, inv. no. I 1022, pl. 6: 1.

Indented beaker with vertical rim, edge cracked-off, the body with six indentations. The base flat, partly concave in the centre.

H: 9 cm
Dia. rim: 6.5 cm
Dia. base: 3.6 cm

Excavation: 1882.
Published: Ljubić 1882, 49, C-1.
Analogies: Is 32; Biaggio Simona 1991, pl. 10: 139.1.019; Ravagnan 1994, 129, no. 242; Whitehouse 1997, 112, no. 171.
Date: Second half of the 1st cent. – beginning of the 3rd cent.



2. Čaša, inv. br. I 1023, t. 6: 2.

Čaša s naborima. Rub ravno odrezan, u profilu stepeničast, tijelo sa četiri udubljenja, sužuje se prema dnu. Dno ravno, djelomice uvučeno u sredini.

vis: 9,1 cm
pr.r.: 8,3 cm
pr. dna: 3,8 cm

Iskopavanje: 1882. g.
Publicirano: Ljubić 1882, 49, C-2; Damevski 1976, 65, t. 10: 3.
Analogije: Is 32; Lazar 2003, 97, forma 3.5.1.; Biaggio Simona 1991, tav. 10: 139.1.068; Ravagnan 1994, 129, no. 243, 244.
Dat.: druga pol. 1. – početak 3. st.

2. Beaker, inv. no. I 1023, pl. 6: 2.

Indented beaker with vertical rim, edge cracked-off, the body with four indentations, narrowing towards the base. The base flat, partly concave in the centre.

H: 9.1 cm
Dia. rim: 8.3 cm
Dia. base: 3.8 cm

Excavation: 1882.
Published: Ljubić 1882, 49, C-2; Damevski 1976, 65, pl. 10: 3.
Analogies: Is 32; Lazar 2003, 97, form 3.5.1; Biaggio Simona 1991, pl. 10: 139.1.068; Ravagnan 1994, 129, no. 243, 244.
Date: Second half of the 1st cent. – beginning of the 3rd cent



3. Čaša, inv. br. I 1317, t. 6: 3.

Čaša s naborima. Rub ravan, ravno odrezan, tijelo sa četiri udubljenja, cilindrično. Dno s izvučenim stajaćim prstenom, djelomice uvučeno u sredini.

vis.: 8,8 cm
pr. r.: 6,4 cm
pr. dna: 4,6 cm

Iskopavanje: 1882. g.
Publicirano: Ljubić 1882, 50, C-8; Trasparenze 1998, kat.198.
Analogije: Is 35; Goethert-Polaschek 1977, forma 58c; Biaggio Simona 1991, tav. 12: 139.1.036, 2.027, 2.029; Whitehouse 1997, 113, no. 172.
Dat.: druga pol. 1. – početak 3. st.

3. Beaker, inv. no. I 1317, pl. 6: 3.

Indented beaker. The vertical rim, edge cracked-off, the body with four indentations, cylindrical. The base with a tubular base ring, partly concave in the centre.

H: 8.8 cm
Dia. rim: 6.4 cm
Dia. base: 4.6 cm

Excavation: 1882.
Published: Ljubić 1882, 50, C-8; Trasparenze 1998, cat. 198.
Analogies: Is 35; Goethert-Polaschek 1977, forma 58c; Biaggio Simona 1991, pl. 12: 139.1.036, 2.027, 2.029; Whitehouse 1997, 113, no. 172.
Date: Second half of the 1st cent. – beginning of the 3rd cent.



4. Čaša, inv. br. I 1337, t. 6: 4.

Čaša konusnog tijela. Rub zadebljan, ispod ruba nataljena staklena nit. Dno na nataljenoj prstenastoj nozi, blago uvučeno. Tragovi metalnog držača na dnu.

vis.: 8,2 cm
pr. r.: 5,7 cm
pr. dna: 4,5 cm

Iskopavanje: 1882. g.
Publicirano: Ljubić 1882, 50, C-9; t. 4: 13; Ravagnan 1994, 186, no. 365, 366.
Analogije: Calvi 1968, tav. C: 9; Ravagnan 1998, no. 365, 366.
Dat.: druga pol. 1. – 2. st.

4. Beaker, inv. no. I 1337, pl. 6: 4.

Conical beaker with a fire-rounded rim, a glass trail applied below the rim. The slightly concave base with an applied base ring. Traces of a pontil mark on the base.

H: 8.2 cm
Dia. rim: 5.7 cm
Dia. base: 4.5 cm

Excavation: 1882.
Published: Ljubić 1882, 50, C-9; pl. 4: 13; Ravagnan 1994, 186, no. 365, 366.
Analogies: Calvi 1968, pl. C: 9; Ravagnan 1998, nos. 365, 366.
Date: Second half of the 1st cent. – 2nd cent.



5. Čaša, inv. br. I 1336, t. 6: 5.

Zvonasta čaša s ravno odrezanim rubom, blago stepenastog profila. Ispod njega urezana horizontalna linija, a na obodu još tri linije, u širim razmacima. Dno nije sačuvano.

vis.: 11,5 cm
pr. r.: 7,1 cm
pr. dna: 3,5 cm

Nema podataka o iskopavanju.

Publicirano: Ljubić 1882, 49, C, t. 2: 20.

Analogije: Is 29/30; Biaggio Simona 1991, tav. 10: 139.2.011; Whitehouse 1997, 227, no. 385.

Dat.: 1. st.

5. Beaker, inv. no. I 1336, pl. 6: 5.

A bell-shaped beaker with a vertical rim, edge cracked-off. A wheel-cut horizontal line below it, with another three widely spaced lines on the body. The base is not preserved.

H: 11.5 cm
Dia. rim: 7.1 cm
Dia. base: 3.5 cm

No data about excavation.

Published: Ljubić 1882, 49, C, pl. 2: 20.

Analogies: Is 29/30; Biaggio Simona 1991, pl. 10: 139.2.011; Whitehouse 1997, 227, no. 385.

Date: 1st cent.

6. Čaša na nozi, inv. br. I 1032, t. 6: 6.

Čaša cilindričnog tijela na nozi. Rub zadebljan, ravno završava. Ispod ruba nataljena staklena nit. Noga nije sačuvana. Staklo ukrašeno s tri niza horizontalnih tankih brušenih linija.

vis.: 11,2 cm (bez noge)
pr. r.: 6,7 cm

Iskopavanje: 1882. g.

Publicirano: Ljubić 1882, 50, C-6.

Analogije: Is 86; Lazar 2003, 117, forma 3.8.5.; Barkóczi 1988, Abb. 7, 8; Whitehouse 1997, 251, no. 429.

Dat.: druga pol. 3. st.

6. Footed goblet, inv. no. I 1032, pl. 6: 6.

Footed goblet with cylindrical walls. The rim slightly out-turned and fire rounded. A glass trail applied below the rim. The foot is not preserved. The goblet is decorated with three rows of thin ground horizontal lines.

H: 11.2 cm (without the foot)
Dia. rim: 6.7 cm

Excavation: 1882.

Published: Ljubić 1882, 50, C-6.

Analogies: Is 86; Lazar 2003, 117, form 3.8.5.; Barkoczi 1988, Abb. 7, 8; Whitehouse 1997, 251, no. 429.

Date: Second half of the 3rd cent.



7. Čaša na nozi, inv. br. I 1033, t. 6: 7.

Čaša koničnog tijela s razgrnutim rubom, koji je zadebljan. Pod rubom nataljena staklena nit. Čaša se prema dnu širi i prelazi u visoku nogu, koja je posebno puhana i nataljena na tijelo. Stijenke ukrašene nizom horizontalnih ureza i kanelurama. Dekolorirano staklo.

vis.: 15,3 cm
pr. r.: 9,5 cm
pr. noge: 6,4 cm

Nema podataka o iskopavanju.

Publicirano: Ljubić 1882, 49, C-5; t. 4: 6.

Analogije: Is 36b; Barkoczi 1984; Whitehouse 228, no. 387.

Dat.: sredina 2. – prva pol. 3. st.

7. Footed goblet, inv. no. I 1033, pl. 6: 7.

A conical goblet with an everted and thickened rim. An applied glass trail below the rim. The goblet broadens towards the base and then narrows towards the high foot, which was separately blown and applied to the body. The walls are decorated with rows of horizontal lines and grooves. Decoloured glass.

H: 15.3 cm
Dia. rim: 9.5 cm
Dia. foot: 6.4 cm

No data about excavation.

Published: Ljubić 1882, 49, C-5; pl. 4: 6.

Analogies: Is 36b; Barkoczi 1984; Whitehouse 228, no. 387.

Date: Middle of the 2nd cent. – first half of the 3rd cent.

**8. Čaša, ulomak,
inv. br. I2020**

Dno cilindrične čaše sa dva stajaća prstena, nataljena.

Iskopavanje: 1882. g.
Nije publicirano.

**8. Beaker, fragment,
inv. no. I2020**

The base of a cylindrical beaker with a double ring base.

Excavation: 1882.
Unpublished.

Vrčevi



1. Vrč, inv. br. I1065, t. 7: 1.

Vrč kruškolikog tijela. Obod razgrnut prema dolje, a onda ravno prema gore. Tijelo ukrašeno s tri reda brušenih vodoravnih linija. Ručka profilirana, gornji dio nataljen na vrat. Dno ravno.

vis.: 21 cm
pr. r.: 4,3 cm
pr. dna: 5 cm

Nema podataka o iskopavanju.

Publicirano: Damevski 1976, 65, t. 2: 4.
Analogije: var. Is 14; Biaggio Simona 1991, tav. 42: 163.2.116; Whitehouse 1997, 231, no. 393.

Dat.: 1. st.

Jugs

1. Jug, inv. no. I1065, pl. 7: 1.

A jug with a pear-shaped body. The rim folded, edge bent down and up. The body decorated with three rows of wheel-cut horizontal lines. The upper part of the profiled handle was applied to the neck. The base flat.

H: 21 cm
Dia. rim: 4.3 cm
Dia. base: 5 cm

No data about excavation.

Published: Damevski 1976, 65, pl. 2: 4.
Analogies: Var. Is 14; Biaggio Simona 1991, pl. 42: 163.2.116; Whitehouse 1997, 231, no. 393.

Date: 1st cent.



2. Vrč, inv. br. I1067, t. 7: 2.

Vrč kruškolikog tijela. Rub izvučen prema van i onda prema unutra. Ručka neprofilirana, gornji dio nataljen na vrat, dno u sredini malo uvučeno.

vis.: 13,4 cm
pr. r.: 3,8 cm
pr. dna: 5 cm

Nema podataka o iskopavanju.

Publicirano: Damevski 1976, 65, t. 2:3.
Analogije: Is 55a; Lazar 2003, 128, forma 5.1.3.

Dat.: sredina – druga pol. 1. st.

2. Jug, inv. no. I1067, pl. 7: 2.

A jug with a pear-shaped body. The rim folded, edge drawn outwards and then inwards. The upper part of the profiled handle was applied to the neck. The base slightly concave in the centre.

H: 13.4 cm
Dia. rim: 3.8 cm
Dia. base: 5 cm

No data about excavation.

Published: Damevski 1976, 65, pl. 2:3.
Analogies: Is 55a; Lazar 2003, 128, form 5.1.3.

Date: Middle – second half of the 1st cent.



3. Vrč, inv. br. I1006, t. 7: 3.

Vrč trbušastog tijela, malih dimenzija. Rub izvučen prema van i onda prema unutra. Ručka profilirana, gornji dio nataljen na vrat. Dno oblikovano u nogu, u sredini uvučeno.

vis: 11,2 cm
pr. r.: 2,6 cm
pr. dna: 4,2 cm

Iskopavanje: 1882. g.

3. Jug, inv. no. I1006, pl. 7: 3.

A small jug with a globular body. The rim folded, edge drawn outwards and then inwards. The upper part of the profiled handle applied to the neck. The base formed into an open base ring, concave in the centre.

H: 11.2 cm
Dia. rim: 2.6 cm
Dia. base: 4.2 cm

Excavation: 1882.

Publicirano: Ljubić 1882, 51, br. 7; Damevski 1976, 65, t. 7: 2.
 Analogije: Is 52a; Lazar 2003, 128, forma 5.1.3.; Biaggio Simona 1991, tav. 29: 134.2.052; Trasparenze 1998, 162, no. 134; Whitehouse 1997, 188, no. 330.
 Dat.: druga četvrtina – kraj 1. st.

Published: Ljubić 1882, 51, no. 7; Damevski 1976, 65, pl. 7: 2.
 Analogies: Is 52a; Lazar 2003, 128, form 5.1.3.; Biaggio Simona 1991, pl. 29: 134.2.052; Trasparenze 1998, 162, no. 134; Whitehouse 1997, 188, no. 330.
 Date: Second quarter – end of the 1st cent



4. Vrč, inv. br. I 1846, t. 7: 4.

Vrč širokog, razgrnutog ruba, koji je cjevasto savijen prema unutra. Vrat kratak, širok, tijelo trbušasto. Ručka tanka, na ramenu lepezasto proširena, a na rubu završava lepezastom pločicom – izdanakom. Dno na sredini uvučeno.

vis.: 10,2 cm
 pr. r.: 8,4 cm
 pr. dna: 5 cm

Iskopavanje: 1882. g.
 Publicirano: Ljubić 1882, t. 2: 13.
 Analogije: Trasparenze 1998, 181, no. 169; Lazar 2006, 83, br. S35.
 Dat.: druga pol. 1. – 2. st.

4. Jug, inv. no. I 1846, pl. 7: 4.

A jug with a wide, everted rim, tubularly rolled inwards. The neck is short, wide, and the body bellied. The handle thin, with a fan-shaped widening on the shoulder, ending on the rim with a thumb-rest. The base concave in the centre.

H: 10.2 cm
 Dia. rim: 8.4 cm
 Dia. base: 5 cm

Excavation: 1882.
 Published: Ljubić 1882, pl. 2: 13.
 Analogies: Trasparenze 1998, 181, no. 169; Lazar 2006, 83, no. 535.
 Date: Second half of the 1st cent. – 2nd cent.



5. Vrč, inv. br. I 1089, t. 7: 5.

Vrč kuglastog tijela. Obod razgrnut, cjevasto savijen prema unutra, s izljevom. Ručka trakasta, na rubu lepezasto proširena u izdanak. Dno u sredini uvučeno.

vis.: 9 cm
 pr. r.: 4,4 cm
 pr. dna: 3 cm

Iskopavanje: 1882. g.
 Nije publicirano.
 Analogije: Is 56b; Biaggio Simona 1991, tav. 43: 139.1.029; Bonomi 1996, 144, no. 328.
 Dat.: druga pol. 1. – prva pol. 2. st.

5. Jug, inv. no. I 1089, pl. 7: 5.

A globular jug. The rim everted and tubularly curled inwards, with a spout. The ribbon handle spread into a thumb-rest on the rim. The base concave in the centre.

H: 9 cm
 Dia. rim: 4.4 cm
 Dia. base: 3 cm

Excavation: 1882.
 Unpublished.
 Analogies: Is 56b; Biaggio Simona 1991, pl. 43: 139.1.029; Bonomi 1996, 144, no. 328.
 Date: Second half of the 1st cent. – first half of the 2nd cent.

6. Vrč, ulomak, inv. br. I 2013, t. 7: 6.

Ulomak vrata i ručke vrča. Rub savijen prema unutra, s izljevom. Ručka trakasta, povučena iznad ruba u izdanak.

vis: 4,2 cm
 pr. r.: 5 cm

Iskopavanje: 1882. g.
 Publicirano: Ljubić 1882, t. 4: 19
 Analogije: Is 56b; Calvi 1968, no. 152.
 Dat.: druga pol. 1. – prva pol. 2. st.

6. Jug, fragment, inv. no. I 2013, pl. 7: 6.

Fragment of the neck and handle of a jug. The rim curled inwards, with a spout. The ribbon handle drawn out above the rim into a thumb-rest.

H: 4.2 cm
 Dia. rim: 5 cm

Excavation: 1882.
 Published: Ljubić 1882, pl. 4: 19
 Analogies: Is 56b; Calvi 1968, no. 152.
 Date: Second half of the 1st cent. – first half of the 2nd cent.

POSUDE ZA POHRANU

STORAGE VESSELS

Boce

Bottles

KVADRATNE BOCE

SQUARE BOTTLES



1. Boca , inv. br. I 1001, t. 8: 1.

Boca četverokutnog tijela. Rub široki, vodoravan. Ručka koljenasta, široka, lepezasto ukrašena. Dno četvrtasto, ravno sa četiri otisnute koncentrične kružnice.

vis.: 15,5 cm
pr. r.: 4,6 cm
pr.dna: 8,2 cm

Nema podataka o iskopavanju.
Nije publicirano.

Analogije: Is 50a; Lazar 2003, 149, forma 6.3.1.; Trasporenze 1998, 156, no. 115–120.

Dat.: kraj 1. – 2. st.

1. Bottle, inv. no. I 1001, pl. 8: 1.

A bottle with a square body. The rim folded, bent outwards and then inwards, flattened. The handle broad, reeded. The base square and flat with four impressed concentric circles.

H: 15.5 cm
Dia. rim: 4.6 cm
Dia. base: 8.2 cm

No data about excavation.
Unpublished.

Analogies: Is 50a; Lazar 2003, 149, form 6.3.1; Trasporenze 1998, 156, no. 115–120.
Date: End of the 1st cent. – 2nd cent.



2. Boca, inv. br. I 2030, t. 8: 2.

Boca četverokutnog tijela. Rub savijen prema van i onda unutra, spljošten. Dno ravno, ručka profilirana.

vis.: 11,5 cm
pr. r.: 3,2 cm
pr.dna: 5 cm

Nema podataka o iskopavanju, nije sigurno da je iz nekropole Bakar.
Nije publicirano.

Analogije: Is 50a; Lazar 2003, 149, forma 6.3.1.; Trasporenze 1998, 156, no. 115–120.

Dat.: kraj 1. – 2. st.

2. Bottle, inv. no. I 2030, pl. 8: 2.

A bottle with a square body. The rim folded, bent outwards and then inwards, flattened. The base flat, the handle profiled.

H: 11.5 cm
Dia. rim: 3.2 cm
Dia. base: 5 cm

No data about the excavation; uncertain this comes from the Bakar cemetery.
Unpublished.

Analogies: Is 50a; Lazar 2003, 149, form 6.3.1; Trasporenze 1998, 156, no. 115–120.
Date: End of the 1st cent. – 2nd cent.



3. Boca, inv. br. I 1002, t. 8: 3.

Boca četverokutnog tijela. Rub savijen prema van i onda prema unutra, spljošten. Dno ravno, ručka narebrena.

vis.: 15,6 cm
pr. r.: 4,8 cm
pr. dna: 9 cm

Iskopavanje: 1882. g.
Publicirano: Ljubić 1882, 51, br. 16; Damevski 1976, 64, t. 3: 1.

3. Bottle, inv. no. I 1002, pl. 8: 3.

A bottle with a square body. The rim folded, bent outwards and then inwards, flattened. The base flat, the handle ribbed.

H: 15.6 cm
Dia. rim: 4.8 cm
Dia. base: 9 cm

Excavation: 1882.
Published: Ljubić 1882, 51, no. 16; Damevski 1976, 64, pl. 3: 1.

Analogije: Is 50a; Lazar 2003, 149, forma 6.3.1.; Trasprenze 1998, 156, no. 115–120.
Dat.: kraj 1. – 2. st.



4. Boca, inv. br. I 1071, t. 8: 4.

Boca četverokutnog tijela. Rub savijen prema van i onda prema unutra, spljošten. Dno ravno, ukrašeno sa četiri plastične kružnice. Ručka profilirana.

vis.: 14 cm
pr. r.: 2,2 cm
pr. dna : 7,4 cm

Iskopavanje: 1882. g.
Publicirano: Ljubić 1882, 51, B-17.
Analogije: Is 50a; Fadić 1997, 27, no. 54, 55, 57–59. Lazar 2003, 149, forma 6.3.1.
Dat.: kraj 1. – 2. st.

Analogies: Is 50a; Lazar 2003, 149, form 6.3.1; Trasprenze 1998, 156, no. 115–120.
Date: End of the 1st cent. – 2nd cent.

4. Bottle, inv. no. I 1071, pl. 8: 4.

A bottle with a square body. The rim folded, bent outwards and then inwards, flattened. The base flat, decorated with four relief circles. The handle profiled.

H: 14 cm
Dia. rim: 2.2 cm
Dia. base: 7.4 cm

Excavation: 1882.
Published: Ljubić 1882, 51, B-17.
Analogies: Is 50a; Fadić 1997, 27, nos. 54, 55, 57–59. Lazar 2003, 149, form 6.3.1.
Date: End of the 1st cent. – 2nd cent.



5. Boca, inv. br. I 1003, t. 8: 5.

Boca četverokutnog tijela. Rub savijen prema van i onda prema unutra, spljošten. Dno blago uvučeno s reljefnim ukrasom, četiri srcolika ukrasa na rubovima i krug na sredini. Ručka profilirana.

vis.: 16,6 cm
pr. r.: 4,6 cm
pr. dna: 6 cm

Iskopavanje: 1882. g.
Publicirano: Ljubić 1882, 51, br. 14.
Analogije: Lazar 2003, 150, forma 6.3.2.
Dat.: kraj 1. – 2. st.

5. Bottle, inv. no. I 1003, pl. 8: 5.

A bottle with a square body. The rim folded, bent outwards and then inwards, flattened. The base slightly concave with a relief decoration of four heart-shaped decorations at the corners and a circle in the centre. The handle profiled.

H: 16.6 cm
Dia. rim: 46 cm
Dia. base: 6 cm

Excavation: 1882.
Published: Ljubić 1882, 51, no. 14.
Analogies: Lazar 2003, 150, form 6.3.2.
Date: End of the 1st cent. – 2nd cent.



6. Boca, inv. br. I 1069, t. 8: 6.

Boca četverokutnog tijela. Rub savijen prema van i onda prema unutra, spljošten. Dno uvučeno, sa reljefom osmero-lisne rozete. Ručka profilirana.

vis.: 18,4 cm
pr. r.: 3,4 cm
pr. dna: 5,4 cm

Iskopavanje: 1882. g.
Nije publicirano.
Analogije: Lazar 2003, 150, forma 6.3.2.
Dat.: kraj 1. – 2. st.

6. Bottle, inv. no. I 1069, pl. 8: 6.

A bottle with a square body. The rim folded, bent outwards and then inwards, flattened. The base concave with an eight petal rosette in relief. The handle profiled.

H: 18.4 cm
Dia. rim: 3.4 cm
Dia. base: 5.4 cm

Excavation: 1882.
Unpublished.
Analogies: Is 50b; Lazar 2003, 150, form 6.3.2.
Date: End of the 1st cent. – 2nd cent.



7. Boca, inv. br. I 1319, t. 9: 1.

Boca četverokutnog tijela. Rub savijen prema van i onda prema unutra, spljošten. Dno ravno s reljefnim ukrasom romba i četiri plastične kružnice na uglovima. Ručka profilirana.

vis.: 11,2 cm
pr. r.: 2,2 cm
pr. dna: 4 cm

Nema podataka o iskopavanju.
Publicirano: Ljubić 1882, 51, E-18.
Analogije: Is 50b; Mandruzzato, Marcante 2005, 125, no. 81, 82; Lazar 2003, 150, forma 6.3.2.; Lazar 2006, H 10; Foy 2006, 354, MAG-A 7.
Dat.: kraj 1. – 2. st.

7. Bottle, inv. no. I 1319, pl. 9: 1.

A bottle with a square body. The rim folded, bent outwards and then inwards, flattened. The base flat with a relief decoration of a rhomb and four relief circles in the corners. The handle profiled.

H: 11.2 cm
Dia. rim: 2.2 cm
Dia. base: 4 cm

No data about excavation.
Published: Ljubić 1882, 51, E-18.
Analogies: Is 50b; Mandruzzato, Marcante 2005, 125, nos. 81, 82; Lazar 2003, 150, form 6.3.2; Lazar 2006, H 10; Foy 2006, 354, MAG-A 7.
Date: End of the 1st cent. – 2nd cent.



8. Boca, inv. br. I 1070, t. 9: 4.

Boca četverokutnog tijela. Rub savijen prema van i onda prema unutra, spljošten. Dno blago uvučeno s reljefom kružnice i s devet zrakasto raspoređenih trokuta. Ručka češljasta.

vis.: 18,2 cm
pr. r.: 3,8 cm
pr. dna: 4,4 cm

Iskopavanje: 1882. g.
Publicirano: Ljubić 1882, 51, B-11; Damevski 1976, 63, t. 4: 1; Trasparenze 1998, kat. 126.
Analogije: Is 50b; Lazar 2003, 150, forma 6.3.2.
Dat.: kraj 1. – 2. st.

8. Bottle, inv. no. I 1070, pl. 9: 4.

A bottle with a square body. The rim folded, bent outwards and then inwards, flattened. The base slightly concave with a relief of circles and nine radially arranged triangles. The handle reeded.

H: 18.2 cm
Dia. rim: 3.8 cm
Dia. base: 4.4 cm

Excavation: 1882.
Published: Ljubić 1882, 51, B-11; Damevski 1976, 63, pl. 4: 1; Trasparenze 1998, cat. 126.
Analogies: Is 50b; Lazar 2003, 150, form 6.3.2.
Date: End of the 1st cent. – 2nd cent.



9. Boca, inv. br. I 1064, t. 9: 3.

Boca četverokutnog tijela. Rub savijen prema van i onda prema unutra, spljošten. Dno ravno, sa četiri reljefne točke na uglovima i motivom ptice, pijetla na sredini. Ručka profilirana.

vis.: 11,2 cm
pr. r.: 2,8 cm
pr. dna: 3,6 cm

Iskopavanje: 1882. g.
Nije publicirano.
Analogije: Is 50 b; Biaggio Simona 1991, tav. 35: 134.2.048; Lazar 2003, 150, forma 6.3.2.; Amrein 2006, CH 30.
Dat.: 1. st.

9. Bottle, inv. no. I 1064, pl. 9: 3.

A bottle with a square body. The rim folded, bent outwards and then inwards, flattened. The base flat, with four relief points in the corners and a motif of bird in the centre. The handle profiled.

H: 11.2 cm
Dia. rim: 2.8 cm
Dia. base: 3.6 cm

Excavation: 1882.
Unpublished.
Analogies: Is 50b; Biaggio Simona 1991, pl. 35: 134.2.048; Lazar 2003, 150, form 6.3.2; Amrein 2006, CH 30.
Date: 1st cent.



10. Boca, inv. br. I 1068, t. 9: 6.

Boca četverokutnog tijela. Rub savijen prema van i onda prema unutra, spljošten. Na dnu tri koncentrične kružnice i četiri srcolika lista na uglovima i slovima C S G (Gaius Salvius Gratus). Ručka široka, češljasta.

vis.: 16 cm
pr. r.: 4,5 cm
pr. dna: 6 cm

Iskopavanje: 1882. g.
Publicirano: Ljubić 1882, 51, B-12.
Analogije: Is 50b; Mandruzzato, Marcante 2005, 126, no. 88; Lazar 2003, 150, forma 6.3.2.; Rottloff 2006, 164, D-RA 2, 51, 158, 192.
Dat.: 2. – 3. st.

10. Bottle, inv. no. I 1068, pl. 9: 6.

A bottle with a square body. The rim folded, bent outwards and then inwards, flattened. On the base three concentric circles and four heart-shaped leaves in the corners, along with the letters C S G (Gaius Salvius Gratus). The handle broad, reeded.

H: 16 cm
Dia. rim: 4.5 cm
Dia. base: 6 cm

Excavation: 1882.
Published: Ljubić 1882, 51, B-12.
Analogies: Is 50b; Mandruzzato, Marcante 2005, 126, no. 88; Lazar 2003, 150, form 6.3.2.; Rottloff 2006, 164, D-RA 2, 51, 158, 192.
Date: 2nd–3rd cent.



11. Boca, inv. br. I 1004, t. 9: 5.

Boca četverokutnog tijela. Rub širok, savijen prema van i onda unutra, spljošten. Dno s reljefnim ukrasom i slovima: tri koncentrične kružnice, četiri reljefna ispupčenja na rubovima posude i slovima LA-EM-IBL-ASI (Lucius Aemilius Blastus). Ručka profilirana.

vis.: 16 cm
pr. r.: 4,5 cm
pr. dna: 6,4 cm

Iskopavanje: 1882. g.
Publicirano: Ljubić 1882, 51, br. 9.
Analogije: Is 50b; Lazar 2003, 150, forma 6.3.2.; Rottloff 2006, 146.
Dat.: 2. – 3. st.

11. Bottle, inv. no. I 1004, pl. 9: 5.

A bottle with a square body. The rim folded, bent outwards and then inwards, flattened. The base with relief decoration and letters: three concentric circles, four relief protrusions on the edges of the vessel and the letters LA-EM-IBL-ASI (Lucius Aemilius Blastus). The handle profiled.

H: 16 cm
Dia. rim: 4.5 cm
Dia. base: 6.4 cm

Excavation: 1882.
Published: Ljubić 1882, 51, no. 9.
Analogies: Is 50b; Lazar 2003, 150, form 6.3.2.; Rottloff 2006, 146.
Date: 2nd–3rd cent.



12. Boca, inv. br. I 1836, t. 9: 2.

Bočica pravokutnog tijela. Rub širok, savijen prema van i onda unutra, spljošten. Na stijenkama slabo uočljiv ukras ovala. Dno uvučeno, ukras s pet ispupčenja, jedan u svakom kutu i jedan na sredini. Ručke profilirane.

vis.: 9,1 cm
pr. r.: 3 cm
pr. dna: 4,7cm x 3,2 cm

Iskopavanje: 1882. g.
Publicirano: Ljubić 1882, 50, E-3.
Analogije: Is 90; Lazar 2004, 72, br. 75; Surduk AMZ inv. 11368; Amrein 2006, CH 37; Lazar 2006d, 264, H 24; id. 2006c, 274, CRO 18.
Dat.: 2. – 3. st.

12. Bottle, inv. no. I 1836, pl. 9: 2.

A bottle with a square body. The rim folded inwards, flattened. On the walls a poorly visible oval decoration. The base concave, with a decoration of five protrusions, one in each corner and one in the centre. The handle profiled.

H: 9.1 cm
Dia. rim: 3 cm
Dia. base: 4.7 cm x 3.2 cm

Excavation: 1882.
Published: Ljubić 1882, 50, E-3.
Analogies: Is 90; Lazar 2004, 72, no. 75; Surduk AMZ inv. 11368; Amrein 2006, CH 37; Lazar 2006d, 264, H 24; Id. 2006c, 274, CRO 18.
Date: 2nd–3rd cent.

CILINDRIČNE BOCE

**13. Boca,**
inv. br. I 1005, t. 10: 1.

Boca cilindričnog tijela s ručkom. Rub izvučen prema van i onda unutra, spljošten. Tijelo nisko, dno uvučeno. Ručka profilirana.

vis: 12,6 cm
pr. r.: 5,2 cm
pr. dna: 10,8 cm

Iskopavanje: 1882. g.
Publicirano: Ljubić 1882, 51, br. 5.
Analogije: Is 51a; Biaggio Simona 1991, tav. 30: 176.2.135; Trasprenze 1998, 163, no. 135.
Dat.: 1. – početak 2. st.

**14. Boca, ulomci,**
inv. br. I 1338, t. 10: 2.

Ulomci boce cilindričnog tijela s ručkom. Rub izvučen prema dolje i na gore. Tijelo ukrašeno horizontalnim urezanim linijama u više pojasa. Ručka češljasta. Dekolorirano staklo.

vis.: 17,6 cm
pr. r.: 5 cm
pr. dna: 7 cm

Nema podataka o iskopavanju.
Publicirano: Damevski 1976, 65, t. 12: 2.
Analogije: Is 51b; Biaggio Simona 1991, tav. 38: 163.1.001; Lazar 2003, 156, forma 6.3.6.; Whitehouse 1997, 230, no. 391; Trasprenze 1998, 164, no. 136.
Dat.: druga pol. 2. – prva pol. 3. st.

**15. Boca,**
inv. br. I 1007, t. 10: 3.

Boca cilindričnog tijela s ručkom, tijelo se sužuje prema dnu. Ukrašeno je brušenim horizontalnim linijama u pravilnim razmacima. Dno uvučeno. Ručka češljasta.

vis.: 24 cm
pr. dna: 8,2 cm.

Iskopavanje: 1882. g.
Publicirano: Ljubić 1882, 50, br. 1. Damevski 1976,
Analogije: Is 51b; Biaggio Simona 1991, tav. 38: 163.1.001; Trasprenze 1998, 164, no. 136; Lazar 2003, 156, forma 6.3.6.; Whitehouse 1997, 230, no. 391.
Dat.: 1. – druga pol. 2. st.

CYLINDRICAL BOTTLES

13. Bottle,
inv. no. I 1005, pl. 10: 1.

A bottle with a cylindrical body and a handle. The rim folded, bent outwards and then inwards, flattened. The body squat, the base concave. The handle profiled.

H: 12.6 cm
Dia. rim: 5.2 cm
Dia. base: 10.8 cm

Excavation: 1882.
Published: Ljubić 1882, 51, no. 5.
Analogies: Is 51a; Biaggio Simona 1991, pl. 30: 176.2.135; Trasprenze 1998, 163, no. 135.
Date: 1st cent. – beginning of the 2nd cent.

14. Bottle, fragments,
inv. no. I 1338, pl. 10: 2.

Fragments of a cylindrical bottle with a handle. The rim drawn out downwards and then up. The body decorated with horizontal wheel-cut lines in several bands. The handle reeded. Decoloured glass.

H: 17.6 cm
Dia. rim: 5 cm
Dia. base: 7 cm

No data about excavation.
Published: Damevski 1976, 65, pl. 12: 2.
Analogies: Is 51b; Biaggio Simona 1991, pl. 38: 163.1.001; Lazar 2003, 156, form 6.3.6; Whitehouse 1997, 230, no. 391; Trasprenze 1998, 164, no. 136.
Date: Second half of the 2nd cent. – first half of the 3rd cent.

15. Bottle,
inv. no. I 1007, pl. 10: 3.

A cylindrical bottle with a handle, the body narrowing towards the base. Decorated with wheel-cut horizontal lines in regular intervals. The base concave. The handle reeded.

H: 24 cm
Dia. base: 8.2 cm.

Excavation: 1882.
Published: Ljubić 1882, 50, no. 1. Damevski 1976,
Analogies: Is 51b; Biaggio Simona 1991, pl. 38: 163.1.001; Trasprenze 1998, 164, no. 136; Lazar 2003, 156, form 6.3.6; Whitehouse 1997, 230, no. 391.
Date: 1st cent. – second half of the 2nd cent



16. Boca, ulomci,
inv. br. I 1106, I 1846, t. 10: 4.

Ulomci boce cilindričnog tijela s ručkom. Tijelo ukrašeno horizontalno urezanim linijama. Ručka češljasta. Staklo dekolirano.

vis.: 15 cm
pr. dna: 6,2 cm

Iskopavanje: 1882. g.
Publicirano: Ljubić 1882, 50, B-br. 3.
Analogije: Lazar 2003, 156, forma 6.3.6.
Dat.: druga pol. 2. – prva pol. 3. st.

16. Bottle, fragments,
inv. nos. I 1106, I 1846, pl. 10: 4.

Fragments of a cylindrical bottle with a handle. The body decorated with horizontal wheel-cut lines. The handle reeded. De-coloured glass.

H: 15 cm
Dia. base: 6.2 cm

Excavation: 1882.
Published: Ljubić 1882, 50, B-no. 3.
Analogies: Lazar 2003, 156, form 6.3.6.
Date: Second half of the 2nd cent. – first half of the 3rd cent.



17. Boca, ulomci,
inv. br. I 1107, t. 11: 1.

Ulomci boce cilindričnog tijela s ručkom. Tijelo posude ukrašeno urezanim vodoravnim linijama, nejednako raspoređenim. Dno malo uvučeno s dvije urezane kružnice. Ručka češljasta. Staklo mliječno bijelo.

vis.: 15,4 cm
pr. t.: 9 cm
pr. dna: 6,4 cm

Iskopavanje: 1882. g.
Publicirano: Ljubić 1882, 50, B-br. 7.
Analogije: Biaggio Simona 1991, tav. 38: 163.1.001; Trasprenze 1998, 164, no. 136; Lazar 2003, 156, forma 6.3.6.
Dat.: druga pol. 2. – prva pol. 3. st.

17. Bottle, fragments,
inv. no. I 1107, pl. 11: 1.

Fragments of a cylindrical bottle with a handle. The body decorated with horizontal irregularly arranged wheel-cut lines. The base slightly concave with two incised circles. The handle reeded. Opaque white glass.

H: 15.4 cm
Dia. body: 9 cm
Dia. base: 6.4 cm

Excavation: 1882.
Published: Ljubić 1882, 50, B-no. 7.
Analogies: Biaggio Simona 1991, pl. 38: 163.1.001; Trasprenze 1998, 164, no. 136; Lazar 2003, 156, form 6.3.6.
Date: Second half of the 2nd cent. – first half of the 3rd cent.



18. Boca,
inv. br. I 1377, t. 11: 2.

Boca većih dimenzija s dvije ručke, rub savijen nadolje i onda prema gore. Tijelo se prema dnu sužava, ukrašeno nizovima brušenih horizontalnih linija. Donji dio tijela oblikovan u nogu. Ručke profilirane.

vis.: 40,5 cm
pr. r.: 8,6 cm
pr. dna: 10,4 cm

Iskopavanje: 1882. g.
Publicirano: Ljubić 1882, 50, E-a.
Analogije: za formu – Sorokina 1993, 59.
Dat.: kraj 1. – prva pol. 2. st.

18. Bottle,
inv. no. I 1377, pl. 11: 2.

A bottle of large dimensions with two handles, the rim bent downwards and then upwards to form a collar rim. The body narrows towards the base, decorated with rows of grooved horizontal lines. The lower part of the body was shaped into an open ring foot. The handles profiled.

H: 40.5 cm
Dia. rim: 8.6 cm
Dia. base: 10.4 cm

Excavation: 1882.
Published: Ljubić 1882, 50, E-a.
Analogies: for form Sorokina 1993, 59.
Date: End of the 1st cent. – first half of the 2nd cent.

BOCE BEZ RUČKI



19. Boca, inv. br. I 1344, t. 12: 1.

Donji dio boce kruglastog tijela.
Dno ravno.

vis.: 13 cm
pr. dna: 4,8 cm

Iskopavanje: 1882. g.
Nije publicirano.
Analogije: Lazar 2003, 139, forma 6.2.1.
Dat.: 1. st.



20. Boca, inv. br. I 1060, t. 12: 2.

Donji dio boce kruglastog tijela. Dno
ravno.

vis.: 10 cm
pr. dna: 4 cm

Iskopavanje: 1882 g.
Publicirano: Ljubić 1882, 52, E-br. 8.
Analogije: Lazar 2003, 139, forma 6.2.1.
Dat.: 1. st.



21. Boca, inv. br. I 1059, t. 12: 3.

Boca kruglastog tijela, rub ravno odsje-
čen, profilacija između vrata i tijela, dno
uvučeno.

vis.: 11,2 cm
pr. r.: 2 cm
pr.dna: 2,8 cm

Iskopavanje: 1882. g.
Publicirano: Ljubić 1882, 52, E-br. 7; Da-
mevski 1976, 66, t. 13: 2.
Analogije: Lazar 2003, 145, forma 6.2.6.
Dat.: 3. – 4. st.



22. Boca, inv. br. I 1066, t. 12: 4.

Boca kruglastog tijela na visokoj, šupljoj
nozi. Rub ravno odrezan. Vrat i gornji dio
tijela ukrašeni rebrima (puhano u kalup,
savijeno i dopuhano), na vratu tri tanka
horizontalna udubljenja. Dekolorirano
staklo.

vis.: 16 cm
pr. r.: 2 cm
pr.dna: 6 cm

Iskopavanje: 1882. g.
Publicirano: Ljubić 1882, 52, E-br. 62.
Analogije: Trasparenze 1998, 144, no. 101.
Dat.: 2. – 3. st.

BOTTLES WITHOUT HANDLES

19. Bottle, inv. no. I 1344, pl. 12: 1.

The lower part of a globular bottle.
The base flat.

H: 13 cm
Dia. base: 4.8 cm

Excavation: 1882.
Unpublished.
Analogies: Lazar 2003, 139, form 6.2.1.
Date: 1st cent.

20. Bottle, inv. no. I 1060, pl. 12: 2.

The lower part of a globular bottle. The base
flat.

H: 10 cm
Dia. base: 4 cm

Excavation: 1882.
Published: Ljubić 1882, 52, E-no. 8.
Analogies: Lazar 2003, 139, form 6.2.1.
Date: 1st cent.

21. Bottle, inv. no. I 1059, pl. 12: 3.

A bottle with a globular body, the rim cut-
off, indentation between the neck and body,
the base concave.

H: 11.2 cm
Dia. rim: 2 cm
Dia. base: 2.8 cm

Excavation: 1882.
Published: Ljubić 1882, 52, E-no. 7;
Damevski 1976, 66, pl. 13: 2.
Analogies: Lazar 2003, 145, form 6.2.6.
Date: 3rd – 4th cent.

22. Bottle, inv. no. I 1066, pl. 12: 4.

A globular bottle on a high hollow foot. The
rim cut-off straight. The neck and upper
part of the body decorated with ribs (mould
blown, twisted, and free-blown), three thin
horizontal indentations on the neck. De-
coloured glass.

H: 16 cm
Dia. rim: 2 cm
Dia. base: 6 cm

Excavation: 1882.
Published: Ljubić 1882, 52, E-no. 62.
Analogies: Trasparenze 1998, 144, no. 101.
Date: 2nd – 3rd cent.

Urne



1. Urna, inv. br. I 1008, t. 13: 1.

Urna (olla) trbušastog tijela. Rub širok, horizontalan, savijen prema van i prema dolje, zadebljan s donje strane. Dno uvučeno.

vis: 13,8 cm
pr. r.: 13 cm
pr. dna: 5,6 cm

Iskopavanje: 1882. g.
Publicirano: Ljubić 1882, 51, br. 1; Damevski 1976, 64, t. 4: 3.
Analogije: Lazar 2003, 163, forma 7.2.3.
Dat.: druga pol. 1. – početak 3. st.

Jars

1. Jar, inv. no. I 1008, pl. 13: 1.

A jar (olla) with a globular body. The rim wide, horizontal, bent outwards and down, edge thickened. The base concave.

H: 13.8 cm
Dia. rim: 13 cm
Dia. base: 5.6 cm

Excavation: 1882.
Published: Ljubić 1882, 51, no. 1; Damevski 1976, 64, pl. 4: 3.
Analogies: Lazar 2003, 163, form 7.2.3.
Date: Second half of the 1st cent. – beginning of the 3rd cent.



2. Urna, ulomak, inv. br. I 1102a, t. 13: 2.

Ulomci ruba urne. Rub izvučen horizontalno prema van i prema dolje, zadebljan s donje strane.

pr. r.: 18 cm

Nema podataka o iskopavanju.
Nije publicirano.
Analogije: Lazar 2003, 163, forma 7.2.3.
Dat.: druga pol. 1. – početak 3. st.

2. Jar, fragment, inv. no. I 1102a, pl. 13: 2.

Fragments of the rim of a jar. The rim drawn horizontally outwards, down, and inwards, thickened on the lower side.

Dia. rim: 18 cm

No data about excavation.
Unpublished.
Analogies: Lazar 2003, 163, form 7.2.3.
Date: Second half of the 1st cent. – beginning of the 3rd cent.



3. Poklopac, inv. br. I 1031, t. 13: 3.

Poklopac, rub cjevast, savijen prema unutra. Gumb na vrhu nedostaje.

vis.: 5 cm
pr. r.: 13,8 cm

Nema podataka o iskopavanju.
Nije publicirano.
Analogije: Fadić 1997, 39, no. 1133–134. Emona; Ravagnan 1994, 219, no. 441–442.
Dat.: druga pol. 1. – 2. st.

3. Lid, inv. no. I 1031, pl. 13: 3.

Lid, with a tubular rim, curved inwards. A button handle (missing).

H: 5 cm
Dia. rim: 13.8 cm

No data about excavation.
Unpublished.
Analogies: Fadić 1997, 39, nos. 1133–1134; Emona; Ravagnan 1994, 219, nos. 441–442.
Date: Second half of the 1st cent. – 2nd cent.



**4. Urna ili lonac,
inv. br. I 1864, t. 13: 4.**

Urna ili lonac prizmatičnog tijela. Rub širok, zadebljan, razgrnut prema van i prema dolje. Na tijelu otisci plastičnih kružnica – po jedan na svakoj strani. Dno uvučeno, ukrašeno sa sedam plastičnih koncentričnih kružnica.

vis.: 12 cm
pr. r.: 8.2 cm
pr. dna: 9 cm

Iskopavanje: 1882. g.
Publicirano: Ljubić 1882, 52, E-60; Damevski 1976, 64, t. 6: 3.
Analogije: Is 62; Lazar 2003, 158, forma 7.1.1.
Dat.: druga pol. 1. – 2. st.

**4. Square jar,
inv. no. I 1864, pl. 13: 4.**

A jar with a prismatic (square) body. The collar rim is everted outwards and turned downwards. Imprints of relief circles – one on each side. The base concave, decorated with seven concentric circles.

H: 12 cm
Dia. rim: 8.2 cm
Dia. base: 9 cm

Excavation: 1882.
Published: Ljubić 1882, 52, E-60; Damevski 1976, 64, pl. 6: 3.
Analogies: Is 62; Lazar 2003, 158, form 7.1.1.
Date: Second half of the 1st cent. – 2nd cent.

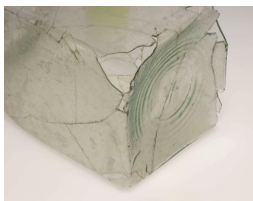

**5. Urna ili lonac,
inv. br. I 1345, t. 14: 1.**

Urna ili lonac prizmatičnog tijela. Rub širok, zadebljan, razgrnut prema van i prema dolje. Dno blago uvučeno, ukrašeno s pet plastičnih koncentričnih kružnica i slovima C – S – C (?) u svakom kutu (jedno nije sačuvano) i slovom A u središtu.

vis.: 28 cm
pr. r.: 15 cm
pr. dna: 14,6 cm

Iskopavanje: 1882. g.
Nije publicirano.
Analogije: Is 62; Lazar 2003, 158, forma 7.1.1.; Lazar 2006, 264, H 20.
Dat.: druga pol. 1. – 2. st.

**5. Urn,
inv. no. I 1345, pl. 14: 1.**

An urn with a prismatic (square) body. The rim wide, thickened, everted outwards and turned downwards. The base slightly concave, decorated with five relief concentric circles and the letters C – S – C? In each corner (one is not preserved) and the letter A in the centre.

H: 28 cm
Dia. rim: 15 cm
Dia. base: 14.6 cm

Excavation: 1882.
Unpublished.
Analogies: Is 62; Lazar 2003, 158, form 7.1.1; Lazar 2006, 264, H 20.
Date: Second half of the 1st cent. – 2nd cent.

**6. Urna, fragmenti,
inv. br. I 1010**

Nekoliko fragmenata trbušaste urne.
Iskopavanje: 1880. g.
Nije publicirano.

**6. Urn, fragments,
inv. no. I 1010**

Several fragments of a globular urn.
Excavation: 1880.
Unpublished.

Varia



1. Riton, inv. br. I 1092, t. 15:1.

Riton s rubom savijenim prema van i nadolje, vrat kratak, završni dio na donjoj strani otvoren – odlomljen (?)

vis.: 22,5 cm

pr. r.: 4,6 cm

Iskopavanje: 1882. g.

Publicirano: Ljubić 1882, 52, E-63.

Analogije: Fadić 1997, 39, no. 138; Trasparenze 1998, 208, no. 218; Lazar 2004, 61, br. 40; Mandruzzato, Marcante 2005, 113, no. 333; Ravagnan 1994, 236, no. 471.

Dat.: prva pol. 1. st.



2. Epruveta / sifon (?), inv. br. I 1861, t. 15: 2.

Epruveta, duga uska cijev na sredini kruškoliko proširena. Na jednom kraju se lučno savija. Oba završetka su oštećena.

duž.: 26 cm

pr. r.: 1,2 cm

pr. t.: 3,8 cm

Nema podataka o iskopavanju.

Nije publicirano.

Analogije: Is 105; Mandruzzato, Marcante 2005, 35, no. 329.

Dat.: 1. st.

Varia

1. Rhyton, inv. no. I 1092, pl. 15:1.

A rhyton with a rim curled outwards and downwards, a short neck, the end on the lower side open – broken off?

H: 22.5 cm

Dia. rim: 4.6 cm

Excavation: 1882.

Published: Ljubić 1882, 52, E-63.

Analogies: Fadić 1997, 39, no. 138; Trasparenze 1998, 208, no. 218; Lazar 2004, 61, no. 40; Mandruzzato, Marcante 2005, 113, no. 333; Ravagnan 1994, 236, no. 471.

Date: First half of the 1st cent.

2. Test-tube / siphon?, inv. no. I 1861, pl. 15: 2.

A long narrow tube with a pear-shaped broadening in the middle. One end bends in an arch. Both ends are damaged.

L.: 26 cm

Dia. rim: 1.2 cm

Dia. body: 3.8 cm

No data about excavation.

Unpublished.

Analogies: Is 105; Mandruzzato, Marcante 2005, 35, no. 329.

Date: 1st cent.



3. Bočica s dvije ručke – minijturna amfora, inv. br. I 1316, t. 15: 3.

Bočica izduženog tijela s dvije ručke, rub cjevasto uvijen unutra. Tijelo četvrtasto, sa sve četiri strane udubljeno, sužava se prema dnu. Dno blago uvučeno. Ručke trakaste, tanke. Vjerojatno je bila sastavni dio unutrašnjosti veće posude (?), od koje je sačuvan dio dna, nataljen na dnu amforice.

vis: 8,8 cm

pr. r.: 2,2 cm

pr. dna: 1,8 cm

Iskopavanje: 1882. g.

Nije publicirano.

Analogije: za formu – Mandruzzato, Marcante 2007, 76, br. 124.

Dat.: 1. – 2. st. (?)

3. A small flask with two handles – a miniature amphora, inv. no. I 1316, pl. 15: 3.

A small flask with an elongated body and two handles, the rim tubularly curved inwards. The body square, indented on all four sides, narrowing towards the bottom. The base slightly concave. Thin ribbon handles. It was probably a component part of the interior of some larger vessel (?), of which a part of the base was preserved, attached to the base of the miniature amphora.

H: 8.8 cm

Dia. rim: 2.2 cm

Dia. base: 1.8 cm

Excavation: 1882.

Unpublished.

Analogies: for form – Mandruzzato, Marcante 2007, 76, no. 124.

Date: 1st – 2nd cent.?

KOZMETIČKO POSUĐE



1. Vrčić, inv. br. I 1315, t. 15: 4.

Vrčić s dvije ručke (aryballos). Staklo jantarne boje, ručke od stakla tamno plave boje. Obod razgrnut prema dolje, a onda ravno prema gore, dno s izvučenim stajalnim prstenom. Ručke profilirane.

vis: 7,2 cm
pr. r.: 2,2 cm
pr. dna: 3,2 cm

Iskopavanje: 1882. g.
Publicirano: Ljubić 1882, 50, B-2.
Analogije: Stern 2001, 70, no. 13; Ravagnan 1994, 43, no. 49; trasparenze 1998, 132, no. 79–81.
Dat.: sredina – kraj 1. st.

COSMETIC VESSELS

1. Small jug, inv. no. I 1315, pl. 15: 4.

A small two-handed jug – *aryballos*. The rim everted downwards and then straight up, the base with a tubular base ring. The handles profiled. Amber glass, the handles dark blue.

H: 7.2 cm
Dia. rim: 2.2 cm
Dia. base: 3.2 cm

Excavation: 1882.
Published: Ljubić 1882, 50, B-2.
Analogies: Stern 2001, 70, no. 13; Ravagnan 1994, 43, no. 49; trasparenze 1998, 132, nos. 79–81.
Date: Middle – end of the 1st cent.



2. Merkur bočica, inv. br. I 1062, t. 16: 1.

Merkur bočica četverokutnog tijela, koje se pri dnu sužava. Dno ravno s reljefnim ukrasom, četiri duguljasta listića križno složena. Dekolorirano staklo.

vis: 9,6 cm
pr. dna: 3 cm

Iskopavanje: 1882. g.
Publicirano: Ljubić 1882, 52, E, br. 61.
Analogije: Facchini 1995, tav. A-B.
Dat.: 2. – 3. st.

2. Mercury flask, inv. no. I 1062, pl. 16: 1.

A Mercury flask with a square body that narrows towards the bottom. The base flat with a relief decoration of four elongated leaves placed in a cross. Decoloured glass.

H: 9.6 cm
Dia. base: 3 cm

Excavation: 1882.
Published: Ljubić 1882, 52, E, no. 61.
Analogies: Facchini 1995, pl. A-B.
Date: 2nd – 3rd cent.



3. Bočica osmerokutnog tijela, inv. br. I 1090, t. 16: 2.

Bočica osmerokutnog tijela, koje se pri dnu sužava (pseudo-Merkur bočica). Dno ravno s pet plastičnih kružnica, nepravilno raspoređenih.

vis.: 15 cm
pr. r.: 2,8 cm
pr. dna: 2,6 cm

Iskopavanje: 1880–1882. g.
Publicirano: Ljubić 1882, 52, E-65.
Analogije: Fadić 2005; Lazar 2006c, 275, CRO 37.
Dat.: 2. – 3. st.

3. Small octagonal flask, inv. no. I 1090, pl. 16: 2.

A flask with an octagonal body that narrows towards the bottom (pseudo-Mercury flask). The base flat with five relief circles arranged irregularly.

H: 15 cm
Dia. rim: 2.8 cm
Dia. base: 2.6 cm

Excavation: 1880–1882.
Published: Ljubić 1882, 52, E-65.
Analogies: Fadić 2005; Lazar 2006c, 275, CRO 37.
Date: 2nd – 3rd cent.



**4. Minijaturna urna,
inv. br. I1011, t. 16: 3.**

Minijaturna trbušasta urna. Rub razgrnut i savijen prema unutra, dno u sredini uvučeno.

vis.: 7,8 cm
pr. r.: 5,8 cm
pr. dna: 3,6 cm

Iskopavanje: 1882. g.
Publicirano: Ljubić 1882, 52, br. 4.
Analogije: Is 68; Lazar 2003, 170, forma 8.2.3.
Dat.: 1. – 2. st.

**4. Miniature urn,
inv. no. I1011, pl. 16: 3.**

A miniature globular urn. The rim everted and bent inwards, the base concave in the centre.

H: 7.8 cm
Dia. rim: 5.8 cm
Dia. base: 3.6 cm

Excavation: 1882.
Published: Ljubić 1882, 52, no. 4.
Analogies: Is 68; Lazar 2003, 168, form 8.2.3.
Date: 1st – 2nd cent.



**5. Minijaturna urna,
inv. br. I1012, t. 16: 4.**

Minijaturna trbušasta urna. Rub razgrnut i savijen prema unutra, dno u sredini uvučeno.

vis: 5,4 cm
pr. r.: 5,8 cm
pr. dna: 3 cm

Iskopavanje: 1882. g.
Publicirano: Ljubić 1882, 52; Damevski 1976, 64, t. 3: 5.
Analogije: Is 68; Lazar 2003, 168, forma 8.2.1.
Dat.: 1. – 2. st.

**5. Miniature urn,
inv. no. I1012, pl. 16: 4.**

A miniature globular urn. The rim everted and bent inwards, the base concave in the centre.

H: 5.4 cm
Dia. rim: 5.8 cm
Dia. base: 3 cm

Excavation: 1882.
Published: Ljubić 1882, 52; Damevski 1976, 64, pl. 3: 5.
Analogies: Is 68; Lazar 2003, 168, form 8.2.1.
Date: 1st – 2nd cent.



**6. Minijaturna urna,
inv. br. I1013, t. 16: 5.**

Minijaturna trbušasta urna. Rub širok, horizontalno razgrnut i savijen prema unutra, dno u sredini uvučeno.

vis.: 3,8 cm
pr. r.: 4 cm.
pr. dna: 1,8 cm

Iskopavanje: 1882. g.
Publicirano: Ljubić 1882, 52, br. 6.
Analogije: Is 68; Lazar 2003, 170, forma 8.2.3.
Dat.: 1. – 2. st.

**6. Miniature urn,
inv. no. I1013, pl. 16: 5.**

A miniature globular urn. The rim wide, horizontally everted, and bent inwards, the base concave in the centre.

H: 3.8 cm
Dia. rim: 4 cm.
Dia. base: 1.8 cm

Excavation: 1882.
Published: Ljubić 1882, 52, no. 6.
Analogies: Is 68; Lazar 2003, 168, form 8.2.3.
Date: 1st – 2nd cent.



**7. Minijaturna urna,
inv. br. I1318, t. 16: 6.**

Minijaturna trbušasta urna. Rub horizontalno razgrnut prema van, prstenasto zadebljan, dno u sredini uvučeno.

vis.: 7 cm
pr. r.: 6,4 cm
pr. dna: 3,6 cm

Iskopavanje: 1882. g.
Publicirano: Ljubić 1882, 50, C-2.
Analogije: Is 68; Lazar 2003, 168, forma 8.2.1.
Dat.: 1. – 2. st.

**7. Miniature urn,
inv. no. I1318, pl. 16: 6.**

A miniature globular urn. The rim horizontally everted outwards, with a ring-like thickening, the base concave in the centre.

H: 7 cm
Dia. rim: 6.4 cm
Dia. base: 3.6 cm

Excavation: 1882.
Published: Ljubić 1882, 50, C-2.
Analogies: Is 68; Lazar 2003, 168, form 8.2.1.
Date: 1st – 2nd cent.

Balzamariji

BALZAMARIJI CJEVASTOG TIJELA

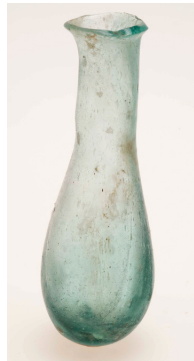

1. Balzamarij, inv. br. I2027, t. 17: 1.

Balzamarij cjevastog tijela. Rub razgrnut prema van. Vrat širi, cilindričan. Dno oblo.

vis.: 8,1 cm
pr. r.: 1,9 cm
pr. dna: 1 cm

Iskopavanje: 1882. g.
Publicirano: Ljubić 1882, 52, E, br. 57.
Analogije: Lazar 2003, 175, forma 8.6.1.;
Rütli 1991, AR 138.
Dat.: 1. st. – prva pol. 2. st.



2. Balzamarij, inv. br. I2025, t. 17: 2.

Balzamarij cjevastog tijela. Rub nedostaje. Dno usko, oblo.

vis.: 8,4 cm
pr. r.: 1,5 cm
pr. dna: 1 cm

Nema podataka o iskopavanju.
Nije publicirano.
Analogije: Lazar 2003, 175, forma 8.6.1.
Dat.: 1. st. – prva pol. 2. st.

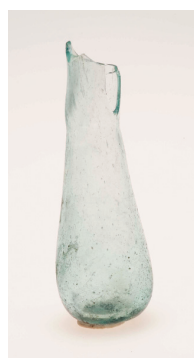

3. Balzamarij, inv. br. I2004

Balzamarij cjevastog tijela. Dno ravno.

vis.: 5,8 cm
pr. t.: 1,9 cm

Nema podataka o iskopavanju.
Nije publicirano.
Analogije: Lazar 2003, 175, forma 8.6.1.
Dat.: 1. st. – prva pol. 2. st.



4. Balzamarij, inv. br. I1075

Balzamarij cjevastog tijela. Rub izvučen prema van. Dno na sredini blago uvučeno.

vis.: 7,7 cm
pr. r.: 2 cm
pr. dna: 3 cm

Iskopavanje: 1882. g.
Publicirano: Ljubić 1882, 52, E, br. 42.
Analogije: Lazar 2003, 175, forma 8.6.1.
Dat.: 1. st. – prva pol. 2. st.

Balsamaria

TUBULAR BALSAMARIA

1. Balsamarium, inv. no. I2027, pl. 17: 1.

Balsamarium with a tubular body. Everted rim. Wide cylindrical neck. Base rounded.

H: 8.1 cm
Dia. rim: 1.9 cm
Dia. base: 1 cm

Excavation: 1882.
Published: Ljubić 1882, 52, E, no. 57.
Analogies: Lazar 2003, 175, form 8.6.1;
Rütli 1991, AR 138.
Date: 1st cent. – first half of the 2nd cent.

2. Balsamarium, inv. no. I2025, pl. 17: 2.

Balsamarium with a tubular body. Rim missing. Base narrow and rounded.

H: 8.4 cm
Dia. rim: 1.5 cm
Dia. base: 1 cm

No data about excavation.
Unpublished.
Analogies: Lazar 2003, 175, form 8.6.1.
Date: 1st cent. – first half of the 2nd cent.

3. Balsamarium, inv. no. I2004

Balsamarium with a tubular body. Base flat.

H: 5.8 cm
Dia. body: 1.9 cm

No data about excavation.
Unpublished.
Analogies: Lazar 2003, 175, form 8.6.1.
Date: 1st cent. – first half of the 2nd cent.

4. Balsamarium, inv. no. I1075

Balsamarium with a tubular body. Everted rim. Base slightly concave in the center.

H: 7.7 cm
Dia. rim: 2 cm
Dia. base: 3 cm

Excavation: 1882.
Published: Ljubić 1882, 52, E, no. 42.
Analogies: Lazar 2003, 175, form 8.6.1.
Date: 1st cent. – first half of the 2nd cent.



5. Balzamarij, inv. br. I 1075/I

Balzamarij cjevastog tijela. Rub razgrnut prema gore. Dno na sredini blago uvučeno.

vis.: 6,5 cm
pr. r.: 2 cm
pr. dna: 1 cm

Iskopavanje: 1882. g.
Nije publicirano.
Analogije: Lazar 2003, 175, forma 8.6.1.
Dat.: 1. st. – prva pol. 2. st.

5. Balsarium, inv. no. I 1075/I

Balsarium with a tubular body. Rim everted upwards. Base slightly concave in the center.

H: 6.5 cm
Dia. rim: 2 cm
Dia. base: 1 cm

Excavation: 1882.
Unpublished.
Analogies: Lazar 2003, 175, form 8.6.1.
Date: 1st cent. – first half of the 2nd cent.



6. Balzamarij, inv. br. I 1083

Balzamarij cjevastog tipa. Dno usko, oblo.

vis.: 6 cm
Pr. t.: 1,6 cm
Pr. dna: 5 cm

Iskopavanje: Kupljen je 1906. g., nalazište Sarazinovo, vinograd A. Benca.
Nije publicirano.
Analogije: Lazar 2003, 175, forma 8.6.1.
Dat.: 1. st. – prva pol. 2. st.

6. Balsarium, inv. no. I 1083

Balsarium with a tubular body. Base narrow and rounded.

H: 6 cm
Dia. body: 1.6 cm
Dia. base: 5 cm

Excavation: Purchased in 1906, at the site of Sarazinovo, the vineyard of A. Benac.
Unpublished.
Analogies: Lazar 2003, 175, form 8.6.1.
Date: 1st cent. – first half of the 2nd cent.



7. Balzamarij, inv. br. I 1096

Balzamarij cjevastog tijela. Rub razgrnut prema gore. Dno na sredini uvučeno.

vis.: 8,8 cm
pr. r.: 2 cm
pr. dna: 2 cm

Iskopavanje: 1880–1882. g.
Nije publicirano.
Analogije: Lazar 2003, 175, forma 8.6.1.
Dat.: 1. st. – prva pol. 2. st.

7. Balsarium, inv. no. I 1096

Balsarium with a tubular body. Rim everted upwards. Base concave in the center.

H: 8.8 cm
Dia. rim: 2 cm
Dia. base: 2 cm

Excavation: 1880–1882.
Unpublished.
Analogies: Lazar 2003, 175, form 8.6.1.
Date: 1st cent. – first half of the 2nd cent.



8. Balzamarij, inv. br. I 203 I

Balzamarij cjevastog tijela. Rub nedostaje. Dno usko, oblo.

vis.: 8,2 cm
pr. dna: 1 cm

Nema podataka o iskopavanju.
Nije publicirano.
Analogije: Lazar 2003, 175, forma 8.6.1.
Dat.: 1. st. – prva pol. 2. st.

8. Balsarium, inv. no. I 203 I

Balsarium with a tubular body. Rim missing. Base narrow and rounded.

H: 8.2 cm
Dia. base: 1 cm

No data about excavation.
Unpublished.
Analogies: Lazar 2003, 175, form 8.6.1.
Date: 1st cent. – first half of the 2nd cent.

**BALZAMARIJI CJEVASTOG
TIJELA S PROFILIRANIM
VRATOM**



**9. Balzamarij,
inv. br. I 1042, t. 17: 3.**

Balzamarij cjevastog tijela. Rub razgrnut prema van, nepravilan. Vrat dug, na prelasku u tijelo profiliran. Dno ravno.

vis.: 8,2 cm
pr. r.: 1,8 cm
pr. dna: 1 cm

Iskopavanje: 1882. g.
Publicirano: Ljubić 1882, 52, E, br. 11–56.
Analogije: Is 8; Lazar 2003, 176, forma 8.6.2.; Rütli 1991, AR 129, 130.
Dat.: 2. – 3. st.

**TUBULAR BALSAMARIA
WITH A CONSTRICTION
ON THE NECK**

**9. Balsarium,
inv. no. I 1042, pl. 17: 3.**

Balsarium with a tubular body. Rim everted and irregular. Neck elongated with an constriction. Base flat.

H: 8.2 cm
Dia. rim: 1.8 cm
Dia. base: 1 cm

Excavation: 1882.
Published: Ljubić 1882, 52, E, no. 11–56.
Analogies: Is 8; Lazar 2003, 176, form 8.6.2; Rütli 1991, AR 129, 130.
Date: 2nd – 3rd cent.



**10. Balzamarij,
inv. br. I 1093, t. 17: 4.**

Balzamarij cjevastog tijela. Rub razgrnut prema van. Vrat profiliran. Dno ravno.

vis.: 8 cm
pr. r.: 2 cm
pr. dna: 1 cm

Iskopavanje: 1880–1882. g.
Nije publicirano.
Analogije: Is 8; Lazar 2003, 176, forma 8.6.2.; Rütli 1991, AR 129, 130.
Dat.: 2. – 3. st.

**10. Balsarium,
inv. no. I 1093, pl. 17: 4.**

Balsarium with a tubular body. Rim everted. Neck profiled. Base flat.

H: 8 cm
Dia. rim: 2 cm
Dia. base: 1 cm

Excavation: 1880–1882.
Unpublished.
Analogies: Is 8; Lazar 2003, 176, form 8.6.2; Rütli 1991, AR 129, 130.
Date: 2nd – 3rd cent.



**11. Balzamarij,
inv. br. I 1328a, t. 17: 5.**

Balzamarij cjevastog tijela. Rub razgrnut prema van. Vrat dug. Dno usko, ravno.

vis.: 11 cm
pr. r.: 2,2 cm
pr. dna: 2 cm

Iskopavanje: 1882. g.
Nije publicirano.
Analogije: Is 8; Lazar 2003, 176, forma 8.6.2.; Rütli 1991, AR 129, 130.
Dat.: 2. – 3. st.

**11. Balsarium,
inv. no. I 1328a, pl. 17: 5.**

Balsarium with a tubular body. Rim everted. Neck elongated. Base narrow and flat.

H: 11 cm
Dia. rim: 2.2 cm
Dia. base: 2 cm

Excavation: 1882.
Unpublished.
Analogies: Is 8; Lazar 2003, 176, form 8.6.2; Rütli 1991, AR 129, 130.
Date: 2nd – 3rd cent.



12. Balzamarij, inv. br. I 1043

Balzamarij cjevastog tijela. Rub izvučen prema van. Vrat dug, na prelasku u tijelo profiliran. Dno zaobljeno.

vis.: 10,5 cm
pr. r.: 2,1 cm
pr. dna: 2 cm

12. Balsarium, inv. no. I 1043

Balsarium with a tubular body. Rim everted. Elongated neck, profiled transition to the body. Base rounded.

H: 10.5 cm
Dia. rim: 2.1 cm
Dia. base: 2 cm

Iskopavanje: 1882. g.
Publicirano: Ljubić 1882, 52, E, br. 11–56.
Analogije: Is 8; Lazar 2003, 176, forma 8.6.2.; Rützi 1991, AR 129, 130.
Dat.: 2. – 3. st.

Excavation: 1882.
Published: Ljubić 1882, 52, E, no. 11–56.
Analogies: Is 8; Lazar 2003, 176, form 8.6.2.; Rützi 1991, AR 129, 130.
Date: 2nd – 3rd cent.



13. Balzamarij, inv. br. I 1044

Balzamarij cjevastog tijela. Rub izvučen prema van. Vrat dug, na prelasku u tijelo profiliran. Dno zaobljeno.

vis.: 12,5 cm
pr. r.: 2 cm
pr. dna: 1 cm

Iskopavanje: 1882. g.
Publicirano: Ljubić 1882, 52, E, br. 11–56.
Analogije: Is 8; Lazar 2003, 176, forma 8.6.2.; Rützi 1991, AR 129, 130.
Dat.: 2. – 3. st.

13. Balsamarium, inv. no. I 1044

Balsamarium with a tubular body. Rim everted. Elongated neck, profiled transition to the body. Base rounded.

H: 12.5 cm
Dia. rim: 2 cm
Dia. base: 1 cm

Excavation: 1882.
Published: Ljubić 1882, 52, E, no. 11–56.
Analogies: Is 8; Lazar 2003, 176, form 8.6.2.; Rützi 1991, AR 129, 130.
Date: 2nd – 3rd cent.



14. Balzamarij, inv. br. I 1072

Balzamarij cjevastog tijela. Rub razgrnut prema van, nakošen. Vrat dug, na prelasku u tijelo profiliran. Dno zaobljeno.

vis.: 7,2 cm
pr. r.: 2 cm
pr. dna: 0,5 cm

Iskopavanje: 1882. g.
Nije publicirano.
Analogije: Is 8; Lazar 2003, 176, forma 8.6.2.; Rützi 1991, AR 129, 130.
Dat.: 2. – 3. st.

14. Balsamarium, inv. no. I 1072

Balsamarium with a tubular body. Rim splayed and angled. Elongated neck, profiled transition to the body. Base rounded.

H: 7.2 cm
Dia. rim: 2 cm
Dia. base: 0.5 cm

Excavation: 1882.
Unpublished.
Analogies: Is 8; Lazar 2003, 176, form 8.6.2.; Rützi 1991, AR 129, 130.
Date: 2nd – 3rd cent.



15. Balzamarij, inv. br. I 1073

Balzamarij cjevastog tijela. Rub razgrnut prema van. Vrat kraći od tijela, profilacija između vrata i tijela. Dno ravno.

vis.: 5,9 cm
pr. r.: 1,8 cm
pr. dna.: 1 cm

Iskopavanje: 1882. g.
Publicirano: Ljubić 1882, 52, E, br. 11–56.
Analogije: Is 8; Lazar 2003, 176, forma 8.6.2.; Rützi 1991, AR 129, 130.
Dat.: 2. – 3. st.

15. Balsamarium, inv. no. I 1073

Balsamarium with a tubular body. Rim splayed outwards. Neck shorter than the body, profiled transition. Base flat.

H: 5.9 cm
Dia. rim: 1.8 cm
Dia. base: 1 cm

Excavation: 1882.
Published: Ljubić 1882, 52, E, no. 11–56.
Analogies: Is 8; Lazar 2003, 176, form 8.6.2.; Rützi 1991, AR 129, 130.
Date: 2nd – 3rd cent.



16. Balzamarij, inv. br. I 1081

Balzamarij cjevastog tipa. Rub nakošen prema gore, nepravilan. Vrat duži od tijela, tanak. Dno ravno.

vis.: 9 cm
pr. r.: 2,5 cm
pr. dna: 1 cm

Iskopavanje: 1880. g.
Publicirano: Ljubić 1882, 52, E, br. 58.
Analogije: Is 8; Lazar 2003, 176, forma 8.6.2.; Rütli 1991, AR 129, 130.
Dat.: 2. – 3. st.

16. Balsarium, inv. no. I 1081

Balsarium with a tubular body. Rim angled upwards, irregular. Thin neck longer than the body. Base flat.

H: 9 cm
Dia. rim: 2.5 cm
Dia. base: 1 cm

Excavation: 1880.
Published: Ljubić 1882, 52, E, no. 58.
Analogies: Is 8; Lazar 2003, 176, form 8.6.2; Rütli 1991, AR 129, 130.
Date: 2nd – 3rd cent.



17. Balzamarij, inv. br. I 1084a

Balzamarij cjevastog tipa. Vrat profiliran. Dno ravno.

vis.: 5,8 cm
pr. dna: 1 cm

Iskopavanje: 1880. g.
Nije publicirano.
Analogije: Is 8; Lazar 2003, 176, forma 8.6.2.; Rütli 1991, AR 129, 130.
Dat.: 2. – 3. st.

17. Balsarium, inv. no. I 1084a

Balsarium with a tubular body. Neck profiled. Base flat.

H: 5.8 cm
Dia. base: 1 cm

Excavation: 1880.
Unpublished.
Analogies: Is 8; Lazar 2003, 176, form 8.6.2; Rütli 1991, AR 129, 130.
Date: 2nd – 3rd cent.



18. Balzamarij, inv. br. I 1094

Balzamarij cjevastog tijela. Rub izvučen. Vrat širok. Dno blago uvučeno.

vis.: 9 cm
pr. r.: 2,3 cm
pr. dna: 1,5 cm

Iskopavanje: 1880–1882. g.
Nije publicirano.
Analogije: Is 8; Lazar 2003, 176, forma 8.6.2.; Rütli 1991, AR 129, 130.
Dat.: 2. – 3. st.

18. Balsarium, inv. no. I 1094

Balsarium with a tubular body. Rim everted. Neck wide. Base slightly concave.

H: 9 cm
Dia. rim: 2.3 cm
Dia. base: 1.5 cm

Excavation: 1880–1882.
Unpublished.
Analogies: Is 8; Lazar 2003, 176, form 8.6.2; Rütli 1991, AR 129, 130.
Date: 2nd – 3rd cent.



19. Balzamarij, inv. br. I 1097

Balzamarij cjevastog tijela. Rub izvučen prema gore. Vrat kratak, profiliran. Dno ravno.

vis.: 6,8 cm
pr. r.: 1,8 cm
pr. dna: 1 cm

Iskopavanje: 1880–1882. g.
Publicirano: Ljubić 1882, 52, E, br. 11–56.
Analogije: Is 8; Lazar 2003, 176, forma 8.6.2.; Rütli 1991, AR 129, 130.
Dat.: 2. – 3. st.

19. Balsarium, inv. no. I 1097

Balsarium with a tubular body. Rim everted upwards. Neck short and profiled. Base flat.

H: 6.8 cm
Dia. rim: 1.8 cm
Dia. base: 1 cm

Excavation: 1880–1882.
Published: Ljubić 1882, 52, E, no. 11–56.
Analogies: Is 8; Lazar 2003, 176, form 8.6.2; Rütli 1991, AR 129, 130.
Date: 2nd – 3rd cent.

20. Balzamarij, inv. br. I 1329

Balzamarij cjevastog tijela. Rub razgrnut prema van. Vrat cilindričan. Dno blago uvučeno.

vis.: 8,9 cm
pr. r.: 2,4 cm
pr. dna: 1,5 cm

Iskopavanje: 1882. g.

Nije publicirano.

Analogije: Is 8; Lazar 2003, 176, forma 8.6.2.; Rützi 1991, AR 129, 130.

Dat.: 2. – 3. st.



21. Balzamarij, inv. br. I 2004

Balzamarij cjevastog tijela. Rub i gornji dio vrata nedostaju. Izmjerena postojeća visina. Dno ravno.

vis.: 5,8 cm
pr. dna: 1,5 cm

Nema podataka o iskopavanju.

Nije publicirano.

Analogije: Lazar 2003, 176, forma 8.6.2.; Rützi 1991, AR 129, 130.

Dat.: 2. – 3. st.

20. Balsamarium, inv. no. I 1329

Balsamarium with a tubular body. Rim splayed outwards. Neck cylindrical. Base slightly concave.

H: 8.9 cm
Dia. rim: 2.4 cm
Dia. base: 1.5 cm

Excavation: 1882.

Unpublished.

Analogies: Is 8; Lazar 2003, 176, form 8.6.2.; Rützi 1991, AR 129, 130.

Date: 2nd – 3rd cent.

21. Balsamarium, inv. no. I 2004

Balsamarium with a tubular body. Rim and upper part of the neck missing. Existing height measured. Base flat.

H: 5.8 cm
Dia. base: 1.5 cm

No data about excavation.

Unpublished.

Analogies: Is 8; Lazar 2003, 176, form 8.6.2.; Rützi 1991, AR 129, 130.

Date: 2nd – 3rd cent.

22. Balzamarij, inv. br. I 2012

Balzamarij cjevastog tijela. Rub razgrnut prema gore. Vrat profiliran. Dno usko, ravno.

vis.: 11,2 cm
pr. r.: 2,4 cm
pr. dna: 1 cm

Nema podataka o iskopavanju.

Nije publicirano.

Analogije: Is 8; Lazar 2003, 176, forma 8.6.2.; Rützi 1991, AR 129, 130.

Dat.: 2. – 3. st.



22. Balsamarium, inv. no. I 2012

Balsamarium with a tubular body. Rim everted upwards. Neck profiled. Base narrow and flat.

H: 11.2 cm
Dia. rim: 2.4 cm
Dia. base: 1 cm

No data about excavation.

Unpublished.

Analogies: Is 8; Lazar 2003, 176, form 8.6.2.; Rützi 1991, AR 129, 130.

Date: 2nd – 3rd cent.

23. Balzamarij, inv. br. I 2014

Balzamarij cjevastog tijela. Rub razgrnut prema gore. Vrat dug, profiliran. Dno usko, ravno.

vis.: 8 cm
pr. r.: 1,6 cm
pr. dna: 1 cm

Iskopavanje: 1880–1882. g.

Nije publicirano.

Analogije: Is 8; Lazar 2003, 176, forma 8.6.2.; Rützi 1991, AR 129, 130.

Dat.: 2. – 3. st.



23. Balsamarium, inv. no. I 2014

Balsamarium with a tubular body. Rim everted upwards. Neck long and profiled. Base narrow and flat.

H: 8 cm
Dia. rim: 1.6 cm
Dia. base: 1 cm

Excavation: 1880–1882.

Unpublished.

Analogies: Is 8; Lazar 2003, 176, form 8.6.2.; Rützi 1991, AR 129, 130.

Date: 2nd – 3rd cent.



24. Balzamarij, inv. br. 12015

Balzamarij cjevastog tijela. Rub razgrnut prema van. Vrat dug, profiliran. Dno usko, ravno.

vis.: 7,8 cm
pr. r.: 1,8 cm
pr. dna: 1 cm

Iskopavanje: 1880–1882. g.

Nije publicirano.

Analogije: Is 8; Lazar 2003, 176, forma 8.6.2.; Rütli 1991, AR 129, 130.

Dat.: 2. – 3. st.

24. Balsarium, inv. no. 12015

Balsarium with a tubular body. Rim splayed outwards. Neck long and profiled. Base narrow and flat.

H: 7.8 cm
Dia. rim: 1.8 cm
Dia. base: 1 cm

Excavation: 1880–1882.

Unpublished.

Analogies: Is 8; Lazar 2003, 176, form 8.6.2; Rütli 1991, AR 129, 130.

Date: 2nd – 3rd cent.



25. Balzamarij, inv. br. 12016

Balzamarij cjevastog tijela. Rub razgrnut prema van. Vrat profiliran. Dno usko, ravno.

vis.: 8,1 cm
pr. r.: 2 cm
pr. dna: 1,2 cm

Iskopavanje: 1880–1882. g.

Nije publicirano.

Analogije: Is 8; Lazar 2003, 176, forma 8.6.2.; Rütli 1991, AR 129, 130.

Dat.: 2. – 3. st.

25. Balsarium, inv. no. 12016

Balsarium with a tubular body. Rim splayed outwards. Neck profiled. Base narrow and flat.

H: 8.1 cm
Dia. rim: 2 cm
Dia. base: 1.2 cm

Excavation: 1880–1882.

Unpublished.

Analogies: Is 8; Lazar 2003, 176, form 8.6.2; Rütli 1991, AR 129, 130.

Date: 2nd – 3rd cent.



26. Balzamarij, inv. br. 12024

Balzamarij cjevastog tijela. Vrat kratak, uzak. Dno oblo.

vis.: 4,5 cm
pr. dna: 0,7 cm

Iskopavanje: 1880–1882. g.

Publicirano: Ljubić 1882, 52, E.

Analogije: Is 8; Lazar 2003, 176, forma 8.6.2.; Rütli 1991, AR 129, 130.

Dat.: 2. – 3. st.

26. Balsarium, inv. no. 12024

Balsarium with a tubular body. Neck short and narrow. Base rounded.

H: 4.5 cm
Dia. base: 0.7 cm

Excavation: 1880–1882.

Published: Ljubić 1882, 52, E.

Analogies: Is 8; Lazar 2003, 176, form 8.6.2; Rütli 1991, AR 129, 130.

Date: 2nd – 3rd cent.

27. Balzamarij, inv. br. 12026

Balzamarij cjevastog tijela. Rub razgrnut prema van. Vrat dug, profiliran. Dno ravno.

vis.: 8,5 cm
pr. r.: 2 cm
pr. dna: 1 cm

Nema podataka o iskopavanju.

Nije publicirano.

Analogije: Is 8; Lazar 2003, 176, forma 8.6.2.; Rütli 1991, AR 129, 130.

Dat.: 2. – 3. st.

27. Balsarium, inv. no. 12026

Balsarium with a tubular body. Rim splayed outwards. Neck long and profiled. Base flat.

H: 8.5 cm
Dia. rim: 2 cm
Dia. base: 1 cm

No data about excavation.

Unpublished.

Analogies: Is 8; Lazar 2003, 176, form 8.6.2; Rütli 1991, AR 129, 130.

Date: 2nd – 3rd cent.

**BALZAMARIJI OVOIDNOG
TIJELA S PROFILIRANIM
VRATOM**



**28. Balzamarij,
inv. br. I 1095, t. 17: 6.**

Balzamarij ovoidnog tijela. Rub izvučen prema van. Vrat kratak, profiliran. Dno ravno. Staklo tamno plavo.

vis.: 7,2 cm
pr. r.: 1,8 cm
pr. dna: 1,2 cm

Iskopavanje: 1880–1882. g.
Publicirano: Ljubić 1882, 52, E.
Analogije: Lazar 2003, 179, forma 8.6.3.
Dat.: 2. – 3.st.

**BALSAMARIA WITH AN
OVAL BODY AND A
PROFILED NECK**

**28. Balsarium,
inv. no. I 1095, pl. 17: 6.**

Balsarium with an oval body. Rim splayed outwards. Neck short and profiled. Base flat. Dark blue glass.

H: 7.2 cm
Dia. rim: 1.8 cm
Dia. base: 1.2 cm

Excavation: 1880–1882.
Published: Ljubić 1882, 52, E.
Analogies: Lazar 2003, 179, form 8.6.3.
Date: 2nd – 3rd cent.

29. Balzamarij, inv. br. I 2023



Balzamarij ovoidnog tijela. Rub razgrnut prema van, oštećen. Vrat profiliran. Dno uže, udubljeno.

vis.: 6,4 cm
pr. dna: 1,5 cm

Iskopavanje: 1880–1882. g.
Nije publicirano.
Analogije: Lazar 2003, 179, forma 8.6.3.
Dat.: 2. – 3.st.

29. Balsarium, inv. no. I 2023

Balsarium with an oval body. Rim splayed outwards and damaged. Neck profiled. Base narrow and concave.

H: 6.4 cm
Dia. base: 1.5 cm

Excavation: 1880–1882.
Unpublished.
Analogies: Lazar 2003, 179, form 8.6.3.
Date: 2nd – 3rd cent.

30. Balzamarij, inv. br. I 2031



Balzamarij ovoidnog tijela. Rub razgrnut prema van. Vrat profiliran, dno ravno.

vis.: 5,5 cm
pr. r.: 1,6 cm
pr. dna: 0,6 cm

Iskopavanje: 1880–1882. g.
Nije publicirano.
Analogije: Lazar 2003, 179, forma 8.6.3.
Dat.: 2. – 3.st.

30. Balsarium, inv. no. I 2031

Balsarium with an oval body. Rim splayed outwards. Neck profiled. Base flat.

H: 5.5 cm
Dia. rim: 1.6 cm
Dia. base: 0.6 cm

Excavation: 1880–1882.
Unpublished.
Analogies: Lazar 2003, 179, form 8.6.3.
Date: 2nd – 3rd cent.

31. Balzamarij, inv. br. I 2033

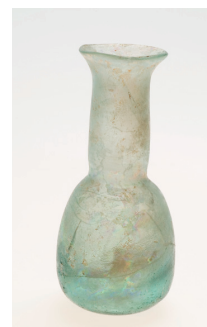

Balzamarij ovoidnog tijela. Rub razgrnut prema van. Vrat profiliran, dno ravno.

vis.: 8 cm
pr. r.: 2,6 cm
pr. dna: 1,8 cm

Iskopavanje: 1880–1882. g.
Nije publicirano.
Analogije: Lazar 2003, 179, forma 8.6.3.
Dat.: 2. – 3.st.

31. Balsarium, inv. no. I 2033

Balsarium with an oval body. Rim splayed outwards. Neck profiled. Base flat.

H: 8 cm
Dia. rim: 2.6 cm
Dia. base: 1.8 cm

Excavation: 1880–1882.
Unpublished.
Analogies: Lazar 2003, 179, form 8.6.3.
Date: 2nd – 3rd cent.

**BALZAMARIJI
OVOIDNOG
TIJELA**



**32. Balzamarij,
inv. br. I 2028, t. 17: 7.**

Balzamarij ovoidnog tijela. Rub razgrnut prema van. Vrat kratak, cilindričan. Dno usko, ravno.

vis.: 8 cm
pr. r.: 2 cm
pr dna: 1 cm

Iskopavanje: 1882. g.
Nije publicirano.
Analogije: Lazar 2003, 180, forma 8.6.4.
Dat.: druga pol. 1. st. – prva pol. 2. st.

**BALSAMARIA WITH
AN ELONGATED
OVOID BODY**

**32. Balsamarium,
inv. no. I 2028, pl. 17: 7.**

Balsamarium with an oval body. Rim everted. Neck short and cylindrical. Base narrow and flat.

H: 8 cm
Dia. rim: 2 cm
Dia. base: 1 cm

Excavation: 1882.
Unpublished.
Analogies: Lazar 2003, 180, form 8.6.4.
Date: Second half of the 1st cent. – first half of the 2nd cent.



33. Balzamarij, inv. br. I 1329

Balzamarij ovoidnog tijela. Rub razgrnut prema van. Vrat cilindričan. Dno blago uvučeno.

vis.: 8,9 cm
pr. r.: 2,4 cm
pr. dna: 1,5 cm

Iskopavanje: 1882. g.
Nije publicirano.
Analogije: Lazar 2003, 180, forma 8.6.4.
Dat.: druga pol. 1. – 2. st.

33. Balsamarium, inv. no. I 1329

Balsamarium with an oval body. Rim everted. Neck cylindrical. Base slightly concave.

H: 8.9 cm
Dia. rim: 2.4 cm
Dia. base: 1.5 cm

Excavation: 1882.
Unpublished.
Analogies: Lazar 2003, 180, form 8.6.4.
Date: Second half of the 1st cent. – first half of the 2nd cent.

**BALZAMARIJI
S TROKUTASTIM TIJELOM**



**34. Balzamarij,
inv. br. I 1331, t. 17: 8.**

Balzamarij malog trokutastog tijela. Rub razgrnut prema van. Vrat dug, uzak. Dno ravno.

vis.: 8,4 cm
pr. r.: 2,2 cm
pr. dna: 2 cm

Iskopavanje: 1882. g.
Publicirano: Ljubić 1882, 52, E, br. 36.
Analogije: Lazar 2003, 181, forma 8.6.5.
Dat.: druga pol. 1. st. – 2. st.

**BALSAMARIA WITH A
TRIANGULAR BODY**

**34. Balsamarium,
inv. no. I 1331, pl. 17: 8.**

Balsamarium with a small triangular body. Rim splayed outwards. Neck long and narrow. Base flat.

H: 8.4 cm
Dia. rim: 2.2 cm
Dia. base: 2 cm

Excavation: 1882.
Published: Ljubić 1882, 52, E, no. 36.
Analogies: Lazar 2003, 181, form 8.6.5.
Date: Second half of the 1st cent. – 2nd cent.

35. Balzamarij

Balzamarij trokutastog tijela.
Vrat dug, uzak, rub nedostaje.
Dno blago uvučeno.

vis.: 7 cm
pr. dna: 2,6 cm

Iskopavanje: 1882. g.
Nije publicirano.
Analogije: Lazar 2003, 181, forma 8.6.5.
Dat.: druga pol. 1. – 2. st.



36. Balzamarij, inv. br. I 1038

Balzamarij trokutastog tijela. Vrat dug, uzak. Dno uvučeno.

vis.: 6,9 cm
pr. t.: 2,5 cm
pr. dna: 2,7 cm

Iskopavanje: 1882. g.
Nije publicirano.
Analogije: Lazar 2003, 181, forma 8.6.5.
Dat.: druga pol. 1. – 2. st.

35. Balsamarium

Balsamarium with a triangular body.
Rim missing. Neck long and narrow.
Base slightly concave.

H: 7 cm
Dia. base: 2.6 cm

Excavation: 1882.
Unpublished.
Analogies: Lazar 2003, 181, form 8.6.5.
Date: Second half of the 1st cent. – 2nd cent.

36. Balsamarium, inv. no. I 1038

Balsamarium with a triangular body. Neck long and narrow. Base concave.

H: 6.9 cm
Dia. body: 2.5 cm
Dia. base: 2.7 cm

Excavation: 1882.
Unpublished.
Analogies: Lazar 2003, 181, form 8.6.5.
Date: Second half of the 1st cent. – 2nd cent.



37. Balzamarij, inv. br. I 1074

Balzamarij trokutastog tijela. Rub cjevasto savijen unutra. Vrat dug, tanak. Dno na sredini jako uvučeno.

vis.: 7,7 cm
pr. r.: 1,9 cm
pr. dna: 3 cm

Iskopavanje: 1882. g.
Publicirano: Ljubić 1882, 52, E, br. 11–56.
Analogije: Lazar 2003, 181, forma 8.6.5.
Dat.: druga pol. 1. – 2. st.

37. Balsamarium, inv. no. I 1074

Balsamarium with a triangular body. Rim tubularly curved inwards. Neck long and narrow. Base highly concave in the middle.

H: 7.7 cm
Dia. rim: 1.9 cm
Dia. base: 3 cm

Excavation: 1882.
Published: Ljubić 1882, 52, E, no. 11–56.
Analogies: Lazar 2003, 181, form 8.6.5.
Date: Second half of the 1st cent. – 2nd cent.



38. Balzamarij, inv. br. I 1077

Balzamarij trokutastog tijela. Rub razgrnut prema van. Vrat dug, cilindričan, uzak. Dno na sredini uvučeno.

vis.: 9 cm
pr. r.: 2 cm
pr. dna: 2 cm

Iskopavanje : 1882. g.
Publicirano: Ljubić 1882, 52, E, br. 57.
Analogije: Lazar 2003, 181, forma 8.6.5.
Dat.: druga pol. 1. – 2. st.

38. Balsamarium, inv. no. I 1077

Balsamarium with a triangular body. Rim splayed outwards. Neck long, cylindrical, narrow. Base concave in the middle.

H: 9 cm
Dia. rim: 2 cm
Dia. base: 2 cm

Excavation: 1882.
Published: Ljubić 1882, 52, E, no. 57.
Analogies: Lazar 2003, 181, form 8.6.5.
Date: Second half of the 1st cent. – 2nd cent.

39. Balzamarij, inv. br. I 1088a

Balzamarij trokutastog tijela. Dno blago uvučeno. Nedostaje rub i vrat. Izmjerena postojeća visina.

vis.: 3,4 cm
pr. dna: 2,2 cm

Iskopavanje: 1880. g.
Nije publicirano.
Analogije: Lazar 2003, 181, forma 8.6.5.
Dat.: druga pol. 1. – 2. st.

39. Balsarium, inv. no. I 1088a

Balsarium with a triangular body. The rim and neck missing. Base slightly concave. The existing height measured.

H: 3.4 cm
Dia. base: 2.2 cm

Excavation: 1880.
Unpublished.
Analogies: Lazar 2003, 181, form 8.6.5.
Date: Second half of the 1st cent. – 2nd cent.

40. Balzamarij, inv. br. I 1104

Balzamarij trokutastog tijela. Vrat dug, uzak. Dno blago uvučeno.

vis.: 10,1 cm
pr. t.: 2,3 cm
pr. dna: 2,4 cm

Iskopavanje: 1882. g.
Nije publicirano.
Analogije: Lazar 2003, 181, forma 8.6.5.
Dat.: druga pol. 1. – 2. st.

40. Balsarium, inv. no. I 1104

Balsarium with a triangular body. Neck long and narrow. Base slightly concave.

H: 10.1 cm
Dia. body: 2.3 cm
Dia. base: 2.4 cm

Excavation: 1882.
Unpublished.
Analogies: Lazar 2003, 181, form 8.6.5.
Date: Second half of the 1st cent. – 2nd cent.

41. Balzamarij, inv. br. I 2006

Dno i vrat balzamarija trokutastog tijela.

vis.: 4,4, cm
pr. dna: 2,4 cm

Iskopavanje: 1880. g.
Nije publicirano.
Analogije: Lazar 2003, 181, forma 8.6.5.
Dat.: druga pol. 1. – 2. st.

41. Balsarium, inv. no. I 2006

The base and neck of a balsarium with a triangular body.

H: 4.4, cm
Dia. base: 2.4 cm

Excavation: 1880.
Unpublished.
Analogies: Lazar 2003, 181, form 8.6.5.
Date: Second half of the 1st cent. – 2nd cent.

**BALZAMARIJI
STOŽASTOG TIJELA
I PROFILIRANOJ VRATA**

**42. Balzamarij,
inv. br. I 1080, t. 17: 9.**

Balzamarij stožastog tijela. Rub široko razgrnut prema van. Vrat dug, profiliran. Dno blago uvučeno.

vis.: 12,2 cm
pr. r.: 2,6 cm
pr. dna: 2,2 cm

Iskopavanje: 1880. g.
Publicirano: Ljubić 1882, 52, E, br. 57.
Analogije: Lazar 2003, 183, forma 8.6.6.
Dat.: druga pol. 1. – prva pol. 3. st.

**BALSAMARIA WITH A
CONICAL BODY AND A
PROFILED NECK**

**42. Balsarium,
inv. no. I 1080, pl. 17: 9.**

Balsarium with a conical body. Rim widely splayed outwards. Neck long and profiled. Base slightly concave.

H: 12.2 cm
Dia. rim: 2.6 cm
Dia. base: 2.2 cm

Excavation: 1880.
Published: Ljubić 1882, 52, E, no. 57.
Analogies: Lazar 2003, 183, form 8.6.6.
Date: Second half of the 1st cent. – first half of the 3rd cent.



43. Balzamarij,
inv. br. I2002, t. 17: 10.

Balzamarij stožastog tijela. Rub široko razgrnut prema van. Vrat dug, profiliran. Dno blago uvučeno.

vis: 11,4 cm
pr. r.: 2,7 cm
pr. dna: 2 cm

Nema podataka o iskopavanju.
Nije publicirano.

Analogije: Lazar 2003, 183, forma 8.6.6.
Dat.: druga pol. 1. – prva pol. 3. st.

43. Balsamarium,
inv. no. I2002, pl. 17: 10.

Balsamarium with a conical body. Rim widely splayed outwards. Neck long and profiled. Base slightly concave.

H: 11.4 cm
Dia. rim: 2.7 cm
Dia. base: 2 cm

No data about excavation.
Unpublished.

Analogies: Lazar 2003, 183, form 8.6.6.
Date: Second half of the 1st cent. – first half of the 3rd cent.



44. Balzamarij,
inv. br. I2003, t. 17: 11.

Balzamarij stožastog tijela. Rub razgrnut prema van i cjevasto savijen unutra. Vrat dug, profiliran. Dno blago uvučeno.

vis.: 6,4 cm
pr. r.: 2,4 cm
pr. dna: 1,8 cm

Iskopavanje: 1880. g.
Nije publicirano.

Analogije: Lazar 2003, 183, forma 8.6.6.
Dat.: druga pol. 1. – prva pol. 3. st.

44. Balsamarium,
inv. no. I2003, pl. 17: 11.

Balsamarium with a conical body. Rim splayed outwards and then bent inwards. Neck long and profiled. Base slightly concave.

H: 6.4 cm
Dia. rim: 2.4 cm
Dia. base: 1.8 cm

Excavation: 1880.
Unpublished.

Analogies: Lazar 2003, 183, form 8.6.6.
Date: Second half of the 1st cent. – first half of the 3rd cent.



45. Balzamarij, inv. br. I1036

Balzamarij stožastog tijela. Rub izvučen prema van. Vrat dug, cilindričan, između vrata i tijela profiliran. Dno uvučeno.

vis.: 8 cm
pr. r.: 2,7 cm
pr. dna: 3 cm

Iskopavanje: 1882. g.
Publicirano: Ljubić 1882, 52, E, br. 11–56.
Analogije: Lazar 2003, 183, forma 8.6.6.
Dat.: druga pol. 1. – prva pol. 3. st.

45. Balsamarium, inv. no. I1036

Balsamarium with a conical body. Rim everted. Neck long and cylindrical, profiled between the neck and body. Base concave.

H: 8 cm
Dia. rim: 2.7 cm
Dia. base: 3 cm

Excavation: 1882.
Published: Ljubić 1882, 52, E, no. 11–56.
Analogies: Lazar 2003, 183, form 8.6.6.
Date: Second half of the 1st cent. – first half of the 3rd cent.



46. Balzamarij, inv. br. I1039

Balzamarij stožastog tijela. Rub razgrnut prema van, oštro, ravno završen. Vrat dug, uzak, na prelasku u tijelo profiliran. Dno ravno.

vis.: 11,8 cm
pr. r.: 2 cm
pr.dna: 3,4 cm

Iskopavanje: 1882. g.
Publicirano: Ljubić 1882, 52, E, br. 57.
Analogije: Lazar 2003, 183, forma 8.6.6.
Dat.: druga pol. 1. – prva pol. 3. st.

46. Balsamarium, inv. no. I1039

Balsamarium with a conical body. Rim everted, edge cut-off. Neck long and narrow, profiled at the transition to the body. Base flat.

H: 11.8 cm
Dia. rim: 2 cm
Dia. base: 3.4 cm

Excavation: 1882.
Published: Ljubić 1882, 52, E, no. 57.
Analogies: Lazar 2003, 183, form 8.6.6.
Date: Second half of the 1st cent. – first half of the 3rd cent.



47. Balzamarij, inv. br. I 1041

Balzamarij stožastog tijela. Rub razgrnut prema van. Vrat dug, cilindričan, na prelasku u tijelo profiliran. Dno uvučeno.

vis.: 10 cm
pr. r.: 2,4 cm
pr. dna: 2 cm

Iskopavanje: 1882. g.
Publicirano: Ljubić 1882, 52, E, br. 57.
Analogije: Lazar 2003, 183, forma 8.6.6.
Dat.: druga pol. 1. – prva pol. 3. st.

47. Balsarium, inv. no. I 1041

Balsarium with a conical body. Rim everted. Neck long and cylindrical, profiled at the transition to the body. Base concave.

H: 10 cm
Dia. rim: 2.4 cm
Dia. base: 2 cm

Excavation: 1882.
Published: Ljubić 1882, 52, E, no. 57.
Analogies: Lazar 2003, 183, form 8.6.6.
Date: Second half of the 1st cent. – first half of the 3rd cent.



48. Balzamarij, inv. br. I 1045

Balzamarij stožastog tijela. Rub razgrnut prema van. Vrat dug, cilindričan, uzak, na prelasku u tijelo profiliran.

vis.: 10,3 cm
pr. r.: 2,5 cm
pr. dna: 2 cm

Iskopavanje: 1882. g.
Publicirano: Ljubić 1882, 52, E, br. 57.
Analogije: Lazar 2003, 183, forma 8.6.6.
Dat.: druga pol. 1. – prva pol. 3. st.

48. Balsarium, inv. no. I 1045

Balsarium with a conical body. Rim everted. Neck long, narrow, and cylindrical, profiled at the transition to the body.

H: 10.3 cm
Dia. rim: 2.5 cm
Dia. base: 2 cm

Excavation: 1882.
Published: Ljubić 1882, 52, E, no. 57.
Analogies: Lazar 2003, 183, form 8.6.6.
Date: Second half of the 1st cent. – first half of the 3rd cent.



49. Balzamarij, inv. br. I 1046

Balzamarij stožastog tijela. Rub razgrnut prema van. Vrat dug, na prelasku u tijelo profiliran. Dno uvučeno.

vis.: 9,7 cm
pr. r.: 2,3 cm
pr. dna: 2,5 cm

Iskopavanje: 1882. g.
Publicirano: Ljubić 1882, 52, E, br. 33.
Analogije: Lazar 2003, 183, forma 8.6.6.
Dat.: druga pol. 1. – prva pol. 3. st.

49. Balsarium, inv. no. I 1046

Balsarium with a conical body. Rim everted. Neck long, profiled at the transition to the body. Base concave.

H: 9.7 cm
Dia. rim: 2.3 cm
Dia. base: 2.5 cm

Excavation: 1882.
Published: Ljubić 1882, 52, E, no. 33.
Analogies: Lazar 2003, 183, form 8.6.6.
Date: Second half of the 1st cent. – first half of the 3rd cent.



50. Balzamarij, inv. br. I 1047

Balzamarij stožastog tijela. Rub razgrnut prema van, nepravilan. Vrat dug, na prelasku u tijelo profiliran. Dno uvučeno.

vis.: 11,5 cm
pr. r.: 2,4 cm
pr. dna: 3 cm

Iskopavanje: 1882. g.
Publicirano: Ljubić 1882, 52, E, br. 57.
Analogije: Lazar 2003, 183, forma 8.6.6.
Dat.: druga pol. 1. – prva pol. 3. st.

50. Balsarium, inv. no. I 1047

Balsarium with a conical body. Rim everted, irregular. Neck long, profiled at the transition to the body. Base concave.

H: 11.5 cm
Dia. rim: 2.4 cm
Dia. base: 3 cm

Excavation: 1882.
Published: Ljubić 1882, 52, E, no. 57.
Analogies: Lazar 2003, 183, form 8.6.6.
Date: Second half of the 1st cent. – first half of the 3rd cent.



51. Balzamarij, inv. br. I 1048

Balzamarij stožastog tijela. Rub razgrnut prema van. Vrat uzak, cilindričan, na prelasku u tijelo profiliran. Dno uvučeno.

vis.: 8,3 cm
pr. dna: 3 cm

Iskopavanje: 1882. g.
Publicirano: Ljubić 1882, 52, E, br. 57.
Analogije: Lazar 2003, 183, forma 8.6.6.
Dat.: druga pol. 1. – prva pol. 3. st.

51. Balsamarium, inv. no. I 1048

Balsamarium with a conical body. Rim everted. Neck long, cylindrical, profiled at the transition to the body. Base concave.

H: 8.3 cm
Dia. base: 3 cm

Excavation: 1882.
Published: Ljubić 1882, 52, E, no. 57.
Analogies: Lazar 2003, 183, form 8.6.6.
Date: Second half of the 1st cent. – first half of the 3rd cent.



52. Balzamarij, inv. br. I 1049

Balzamarij stožastog tijela. Rub razgrnut prema van. Vrat dug, na prelasku u tijelo profiliran. Dno uvučeno.

vis.: 8,5 cm
pr. r.: 2 cm
pr. dna: 2 cm

Iskopavanje: 1882. g.
Publicirano: Ljubić 1882, 52, E, br. 57.
Analogije: Lazar 2003, 183, forma 8.6.6.
Dat.: druga pol. 1. – prva pol. 3. st.

52. Balsamarium, inv. no. I 1049

Balsamarium with a conical body. Rim everted. Neck long, profiled at the transition to the body. Base concave.

H: 8.5 cm
Dia. rim: 2 cm
Dia. base: 2 cm

Excavation: 1882.
Published: Ljubić 1882, 52, E, no. 57.
Analogies: Lazar 2003, 183, form 8.6.6.
Date: Second half of the 1st cent. – first half of the 3rd cent.



53. Balzamarij, inv. br. I 1050

Balzamarij stožastog tijela. Rub razgrnut prema van. Vrat dug, na prelasku u tijelo profiliran. Dno ravno.

vis.: 13 cm
pr. r.: 2,5 cm
pr. dna: 4 cm

Iskopavanje: 1882. g.
Publicirano: Ljubić 1882, 52, E, br. 57.
Analogije: Lazar 2003, 183, forma 8.6.6.
Dat.: druga pol. 1. – prva pol. 3. st.

53. Balsamarium, inv. no. I 1050

Balsamarium with a conical body. Rim everted. Neck long, profiled at the transition to the body. Base flat.

H: 13 cm
Dia. rim: 2.5 cm
Dia. base: 4 cm

Excavation: 1882.
Published: Ljubić 1882, 52, E, no. 57.
Analogies: Lazar 2003, 183, form 8.6.6.
Date: Second half of the 1st cent. – first half of the 3rd cent.

54. Balzamarij, inv. br. I 1078

Balzamarij stožastog tijela. Rub i vrat nedostaju. Dno blago uvučeno.

vis.: 2,7 cm
pr. dna: 3,5 cm

Iskopavanje: 1882. g.
Nije publicirano.
Analogije: Lazar 2003, 183, forma 8.6.6.
Dat.: druga pol. 1. – prva pol. 3. st.

54. Balsamarium, inv. no. I 1078

Balsamarium with a conical body. Rim and neck missing. Base slightly concave.

H: 2.7 cm
Dia. base: 3.5 cm

Excavation: 1882.
Unpublished.
Analogies: Lazar 2003, 183, form 8.6.6.
Date: Second half of the 1st cent. – first half of the 3rd cent.



55. Balzamarij, inv. br. I 1085

Balzamarij stožastog tijela. Vrat dug, debliji, rub nedostaje. Dno ravno.

vis.: 10,3 cm
pr. dna: 2,5 cm

Nema podataka o iskopavanju.
Nije publicirano.

Analogije: Lazar 2003, 183, forma 8.6.6.
Dat.: druga pol. 1. – prva pol. 3. st.

55. Balsarium, inv. no. I 1085

Balsarium with a conical body. Rim missing. Neck long and thick. Base flat.

H: 10.3 cm
Dia. base: 2.5 cm

No data about excavation.
Unpublished.

Analogies: Lazar 2003, 183, form 8.6.6.
Date: Second half of the 1st cent. – first half of the 3rd cent.



56. Balzamarij, inv. br. I 2005

Stožasto tijelo balzamarija.
Dno blago uvučeno.

vis.: 4 cm
pr. dna: 1,2 cm

Iskopavanje: 1880. g.
Nije publicirano.

Analogije: Lazar 2003, 183, forma 8.6.6.
Dat.: druga pol. 1. – prva pol. 3. st.

56. Balsarium, inv. no. I 2005

The conical body of a balsarium.
Base slightly concave.

H: 4 cm
Dia. base: 1.2 cm

Excavation: 1880.
Unpublished.

Analogies: Lazar 2003, 183, form 8.6.6.
Date: Second half of the 1st cent. – first half of the 3rd cent.

**BALZAMARIJI
LUKOVIČASTOG TIJELA**



**57. Balzamarij,
inv. br. I 1053, t. 18: 1.**

Balzamarij lukovičastog tijela. Rub izvučen prema van. Vrat dug, širok, na prelasku u tijelo profiliran. Dno ravno.

vis.: 16 cm
pr. r.: 2,8 cm
pr.dna.: 5,8 cm

Nema podataka o iskopavanju.
Publicirano: Damevski 1976, 65, t. 12: 3.
Analogije: Is 82a; Lazar 2003, 187, forma 8.6.9.; Rütli 1991, AR 140.
Dat.: druga pol. 1. st. – 2. st.

**CANDLESTICK
BALSAMARIA**

**57. Balsarium,
inv. no. I 1053, pl. 18: 1.**

Balsarium with a large conical body. Rim everted. Neck long and wide, profiled at the transition to the body. Base flat.

H: 16 cm
Dia. rim: 2.8 cm
Dia. base: 5.8 cm

No data about excavation.
Published: Damevski 1976, 65, pl. 12: 3.
Analogies: Is 82a; Lazar 2003, 187, form 8.6.9; Rütli 1991, AR 140.
Date: Second half of the 1st cent. – 2nd cent.



**58. Balzamarij,
inv. br. I 1056, t. 18: 2.**

Balzamarij lukovičastog tijela. Rub izvučen horizontalno prema van, cjevasto savijen prema gore. Vrat širok, profiliran. Dno uvučeno.

vis.: 11,4 cm
pr. r.: 3,8 cm
pr. dna: 4 cm

Nema podataka o iskopavanju.
Nije publicirano.
Analogije: Is 82a; Lazar 2003, 187, forma 8.6.9.; Rütli 1991, AR 140.
Dat.: druga pol. 1. st. – 2. st.

**58. Balsarium,
inv. no. I 1056, pl. 18: 2.**

Balsarium with a large conical body. Rim horizontally everted and tubularly bent upwards. Neck wide, profiled. Base concave.

H: 11.4 cm
Dia. rim: 3.8 cm
Dia. base: 4 cm

No data about excavation.
Unpublished.
Analogies: Is 82a; Lazar 2003, 187, form 8.6.9; Rütli 1991, AR 140.
Date: Second half of the 1st cent. – 2nd cent.



59. Balzamarij,
inv. br. I 1061, t. 18: 3.

Balzamarij lukovičastog tijela. Rub razgrnut, cjevasto savijen unutra. Vrat uzak, cilindričan. Dno ravno.

vis.: 15 cm
pr. r.: 3,3 cm
pr. dna: 4,8 cm

Nema podataka o iskopavanju.
Publicirano: Damevski 1976, 65, t. 12: 4.
Analogije: Is 82a; Lazar 2003, 187, forma 8.6.9.; Rütli 1991, AR 140.
Dat.: druga pol. 1. st. – 2. st.

59. Balsamarium,
inv. no. I 1061, pl. 18: 3.

Balsamarium with a large conical body. Rim everted, edge tubularly bent inwards. Neck narrow, cylindrical. Base flat.

H: 15 cm
Dia. rim: 3.3 cm
Dia. base: 4.8 cm

No data about excavation.
Published: Damevski 1976, 65, pl. 12: 4.
Analogies: Is 82a; Lazar 2003, 187, form 8.6.9; Rütli 1991, AR 140.
Date: Second half of the 1st cent. – 2nd cent.



60. Balzamarij, inv. br. I 1009

Balzamarij lukovičastog tijela, fragmentiran. Rub cjevasto savijen prema van. Dno uvučeno.

pr. r.: 4,1 cm
pr.dna: 7 cm

Iskopavanje: Kupljen 1905. g., vinograd P. Andrijanića.
Nije publicirano.
Analogije: Is 82a; Lazar 2003, 187, forma 8.6.9.; Rütli 1991, AR 140.
Dat.: druga pol. 1. st. – 2. st.

60. Balsamarium, inv. no. I 1009

Balsamarium with a large conical body, fragmentary. Rim edge tubularly bent outwards. Base concave.

Dia. rim: 4.1 cm
Dia. base: 7 cm

Excavation: Purchased in 1905, from the vineyard of P. Andrijanić.
Unpublished.
Analogies: Is 82a; Lazar 2003, 187, form 8.6.9; Rütli 1991, AR 140.
Date: Second half of the 1st cent. – 2nd cent.



61. Balzamarij, inv. br. I 1074

Balzamarij lukovičastog tijela. Rub cjevasto savijen unutra. Dno jako uvučeno, staklo dekolirano.

vis.: 7,4 cm
pr. r.: 2 cm
pr. dna: 3 cm

Iskopavanje: 1880. g.
Nije publicirano.
Analogije: Is 82a; Lazar 2003, 187, forma 8.6.9.; Rütli 1991, AR 140.
Dat.: druga pol. 1. st. – 2. st.

61. Balsamarium, inv. no. I 1074

Balsamarium with a large conical body. Rim edge tubularly bent inwards. Base highly concave, glass decolorized.

H: 7.4 cm
Dia. rim: 2 cm
Dia. base: 3 cm

Excavation: 1880.
Unpublished.
Analogies: Is 82a; Lazar 2003, 187, form 8.6.9; Rütli 1991, AR 140.
Date: Second half of the 1st cent. – 2nd cent.

62. Balzamarij

Balzamarij lukovičastog tijela. Rub cjevasto savijen. Dno blago uvučeno.

vis.: 10 cm
pr. r.: 2,4 cm
pr. dna: 2,2 cm

Iskopavanje: 1880. g.
Publicirano: Ljubić 1882, 52, E, br. 57.
Analogije: Is 82a; Lazar 2003, 187, forma 8.6.9.; Rütli 1991, AR 140.
Dat.: druga pol. 1. st. – 2. st.

62. Balsamarium

Balsamarium with a large conical body. Rim tubular. Base slightly concave.

H: 10 cm
Dia. rim: 2.4 cm
Dia. base: 2.2 cm

Excavation: 1880.
Published: Ljubić 1882, 52, E, no. 57.
Analogies: Is 82a; Lazar 2003, 187, form 8.6.9; Rütli 1991, AR 140.
Date: Second half of the 1st cent. – 2nd cent.

63. Balzamarij

Balzamarij lukovičastog tijela. Rub cjevasto savijen i spljošten. Dno blago uvučeno.

vis.: 10 cm
pr. r.: 2,4 cm
pr. dna: 2,2 cm

Iskopavanje: otkup 1905. g. od Pavla Andrijanića.

Nije publicirano.

Analogije: Is 82a; Lazar 2003, 187, forma 8.6.9.; Rützi 1991, AR 140.

Dat.: druga pol. 1. st. – 2. st.



64. Balzamarij, inv. br. I 1327

Balzamarij lukovičastog tijela. Rub horizontalno razgrnut prema van i cjevasto savijen. Dno ravno.

vis.: 10 cm
pr. r.: 2,4 cm
pr. dna: 3 cm

Iskopavanje: 1882. g.

Nije publicirano.

Analogije: Is 82a; Lazar 2003, 187, forma 8.6.9.; Rützi 1991, AR 140.

Dat.: druga pol. 1. st. – 2. st.

63. Balsamarium

Balsamarium with a large conical body. Rim tubular and flattened. Base slightly concave.

H: 10 cm
Dia. rim: 2.4 cm
Dia. base: 2.2 cm

Excavation: Purchased in 1905 from P. Andrijanić.

Unpublished.

Analogies: Is 82a; Lazar 2003, 187, form 8.6.9; Rützi 1991, AR 140.

Date: Second half of the 1st cent. – 2nd cent.

64. Balsamarium, inv. no. I 1327

Balsamarium with a large conical body. Rim horizontally splayed outwards and tubularly bent. Base flat.

H: 10 cm
Dia. rim: 2.4 cm
Dia. base: 3 cm

Excavation: 1882.

Unpublished.

Analogies: Is 82a; Lazar 2003, 187, form 8.6.9; Rützi 1991, AR 140.

Date: Second half of the 1st cent. – 2nd cent.

BALZAMARIJI SPLJOŠTENOG TROKUTASTOG TIJELA



65. Balzamarij, inv. br. I 1037, t. 18: 4.

Balzamarij malog trokutastog tijela. Rub horizontalno razgrnut prema van. Vrat dug, uzak, tijelo kratko. Dno uvučeno.

vis.: 8,8 cm
pr. r.: 2,2 cm
pr. dna: 2 cm

Iskopavanje: 1882. g.

Publicirano: Ljubić 1882, 52, E, br. 57; Damevski 1976, 64, t. 3: 4.

Analogije: Lazar 2003, 188, forma 8.6.10.; Rützi 1991, AR 136; Buljević 2004, 91, no. 220, 227.

Dat.: druga pol. 1. st. – prva pol. 3. st.

BALSAMARIA WITH A FLATTENED TRIANGULAR BODY

65. Balsamarium, inv. no. I 1037, pl. 18: 4.

Balsamarium with a small triangular body. Rim horizontally splayed outwards. Neck long and narrow, body short. Base concave.

H: 8.8 cm
Dia. rim: 2.2 cm
Dia. base: 2 cm

Excavation: 1882.

Published: Ljubić 1882, 52, E, no. 57; Damevski 1976, 64, pl. 3: 4.

Analogies: Lazar 2003, 188, form 8.6.10; Rützi 1991, AR 136; Buljević 2004, 91, no. 220, 227.

Date: Second half of the 1st cent. – first half of the 3rd cent.



66. Balzamarij,
inv. br. I 1079, t. 18: 5.

Balzamarij malog trokutastog tijela. Rub horizontalno razgrnut prema van. Vrat dug, uzak, tijelo kratko. Dno uvučeno.

vis.: 8,6 cm
pr. r.: 2,4 cm
pr.dna.: 2 cm

Iskopavanje: 1882. g.
Nije publicirano.
Analogije: Lazar 2003, 188, forma 8.6.10.;
Rützi 1991, AR 136.
Dat.: druga pol. 1. st. – prva pol. 3. st.

66. Balsamarium,
inv. no. I 1073/I, pl. 18: 5.

Balsamarium with a small triangular body. Rim horizontally splayed outwards. Neck long and narrow, body short. Base concave.

H: 8.6 cm
Dia. rim: 2.4 cm
Dia. base: 2 cm

Excavation: 1882.
Unpublished.
Analogies: Lazar 2003, 188, form 8.6.10;
Rützi 1991, AR 136.
Date: Second half of the 1st cent. – first half of the 3rd cent.



67. Balzamarij,
inv. br. I 1331, t. 18: 6.

Balzamarij malog trokutastog tijela. Rub horizontalno razgrnut prema van. Vrat dug, uzak, tijelo kratko. Dno uvučeno.

vis.: 8 cm
pr. r.: 2,2 cm
pr. dna: 1,6 cm

Iskopavanje: 1882. g.
Nije publicirano.
Analogije: Lazar 2003, 188, forma 8.6.10.;
Rützi 1991, AR 136.
Dat.: druga pol. 1. st. – prva pol. 3. st.

67. Balsamarium,
inv. no. I 1331, pl. 18: 6.

Balsamarium with a small triangular body. Rim horizontally splayed outwards. Neck long and narrow, body short. Base concave.

H: 8 cm
Dia. rim: 2.2 cm
Dia. base: 1.6 cm

Excavation: 1882.
Unpublished.
Analogies: Lazar 2003, 188, form 8.6.10;
Rützi 1991, AR 136.
Date: Second half of the 1st cent. – first half of the 3rd cent.



68. Balzamarij, inv. br. I 1036

Balzamarij malog trokutastog tijela. Rub razgrnut. Vrat dug, cilindričan. Dno uvučeno, staklo dekolorirano.

vis.: 10,4 cm
pr. r.: 2,1 cm
pr. dna: 2 cm

Iskopavanje: 1882. g.
Publicirano: Ljubić 1882, 52, E, br. 11–56.
Analogije: Lazar 2003, 188, forma 8.6.10.; Rützi 1991, AR 136.
Dat.: druga pol. 1. st. – prva pol. 3. st.

68. Balsamarium, inv. no. I 1036

Balsamarium with a small triangular body. Rim splayed. Neck long and cylindrical. Base concave, glass decolorized.

H: 10.4 cm
Dia. rim: 2.1 cm
Dia. base: 2 cm

Excavation: 1882.
Published: Ljubić 1882, 52, E, no. 11–56.
Analogies: Lazar 2003, 188, form 8.6.10;
Rützi 1991, AR 136.
Date: Second half of the 1st cent. – first half of the 3rd cent.



69. Balzamarij, inv. br. I 1040

Balzamarij malog trokutastog tijela. Rub razgrnut. Vrat dug, cilindričan, uzak. Dno uvučeno.

vis.: 10 cm
pr. r.: 2,4 cm
pr. dna: 2 cm

Iskopavanje: 1882. g.
Publicirano: Ljubić 1882, 52, E, br. 57.
Analogije: Lazar 2003, 188, forma 8.6.10.; Rützi 1991, AR 136.
Dat.: druga pol. 1. st.– prva pol. 3. st.

69. Balsamarium, inv. no. I 1040

Balsamarium with a small triangular body. Rim splayed. Neck long, cylindrical, and narrow. Base concave.

H: 10 cm
Dia. rim: 2.4 cm
Dia. base: 2 cm

Excavation: 1882.
Published: Ljubić 1882, 52, E, no. 57.
Analogies: Lazar 2003, 188, form 8.6.10;
Rützi 1991, AR 136.
Date: Second half of the 1st cent. – first half of the 3rd cent.



70. Balzamarij, inv. br. I 1077

Balzamarij malog trokutastog tijela. Rub razgrnut. Vrat dug, cilindričan, uzak. Dno uvučeno.

vis.: 9 cm
pr. r.: 2,2 cm
pr. dna: 2,4 cm

Iskopavanje: 1882. g.
Nije publicirano.

Analogije: Lazar 2003, 188, forma 8.6.10.; Rütti 1991, AR 136.

Dat.: druga pol. 1. st. – prva pol. 3. st.

70. Balsarium, inv. no. I 1077

Balsarium with a small triangular body. Rim splayed. Neck long, cylindrical, narrow. Base concave.

H: 9 cm
Dia. rim: 2.2 cm
Dia. base: 2.4 cm

Excavation: 1882.
Unpublished.

Analogies: Lazar 2003, 188, form 8.6.10; Rütti 1991, AR 136.

Date: Second half of the 1st cent. – first half of the 3rd cent.



71. Balzamarij, inv. br. I 1079

Balzamarij malog trokutastog tijela. Rub horizontalno razgrnut. Vrat dug, uzak. Dno uvučeno.

vis.: 8,4 cm
pr. r.: 2,3 cm
pr. dna: 2 cm

Iskopavanje: 1880. g.
Publicirano: Ljubić 1882, 52, E, br. 57.

Analogije: Lazar 2003, 188, forma 8.6.10.; Rütti 1991, AR 136.

Dat.: druga pol. 1. st. – prva pol. 3. st.

71. Balsarium, inv. no. I 1079

Balsarium with a small triangular body. Rim horizontally splayed. Neck long and narrow. Base concave.

H: 8.4 cm
Dia. rim: 2.3 cm
Dia. base: 2 cm

Excavation: 1880.

Published: Ljubić 1882, 52, E, no. 57.

Analogies: Lazar 2003, 188, form 8.6.10; Rütti 1991, AR 136.

Date: Second half of the 1st cent. – first half of the 3rd cent.

**BALZAMARIJI NISKOĞ
ŠIROKOĞ TIJELA**

**BALSAMARIA WITH A
WIDE FLATTENED BODY**



**72. Balzamarij,
inv. br. I 1051, t. 18: 7.**

Balzamarij niskog širokog tijela. Rub horizontalno razgrnut prema van, cjevasto savijen prema gore. Vrat širok, dug. Dno uvučeno.

vis.: 18 cm
pr. r.: 5,6 cm
pr. dna: 9 cm

Nema podataka o iskopavanju.
Nije publicirano.

Analogije: Is 82b2; Lazar 2003, 188, forma 8.6.11.

Dat.: druga pol. 2. – prva pol. 3. st.

**72. Balsarium,
inv. no. I 1051, pl. 18: 7.**

Balsarium with a wide flattened body. Rim horizontally splayed outward, tubularly curved upwards. Neck wide and long. Base concave.

H: 18 cm
Dia. rim: 5.6 cm
Dia. base: 9 cm

No data about excavation.

Unpublished.

Analogies: Is 82b2; Lazar 2003, 188, form 8.6.11.

Date: End of the 1st cent. – 2nd cent.



73. Balzamarij,
inv. br. I 1052, t. 18: 8.

Balzamarij niskog širokog tijela. Rub cjevasto savijen prema gore. Dno uvučeno, staklo dekolirirano.

vis.: 13,4 cm
pr. r.: 4,6 cm
pr. dna: 7 cm

Iskopavanje: 1880. g.
Nije publicirano.
Analogije: Is 82b2; Lazar 2003, 188, forma 8.6.11.
Dat.: druga pol. 2. – prva pol. 3. st.

73. Balsamarium,
inv. no. I 1052, pl. 18: 8.

Balsamarium with a wide flattened body. Rim tubularly curved upwards. Base concave, glass decolorized.

H: 13.4 cm
Dia. rim: 4.6 cm
Dia. base: 7 cm

Excavation: 1880.
Unpublished.
Analogies: Is 82b2; Lazar 2003, 188, form 8.6.11.
Date: End of the 1st cent. – 2nd cent.



74. Balzamarij,
inv. br. I 1330, t. 18: 9.

Balzamarij niskog širokog tijela. Rub horizontalno razgrnut prema van i cjevasto savijen prema gore. Dno blago uvučeno.

vis.: 7,4 cm
pr. r.: 2,2 cm
pr. dna: 4 cm

Iskopavanje: 1882. g.
Publicirano: Ljubić 1882, 52, E br. 39.
Analogije: Is 82b2; Lazar 2003, 188, forma 8.6.11.
Dat.: druga pol. 2. – prva pol. 3. st.

74. Balsamarium,
inv. no. I 1330, pl. 18: 9.

Balsamarium with a wide flattened body. Rim horizontally splayed outwards and tubularly curved upwards. Base slightly concave.

H: 7.4 cm
Dia. rim: 2.2 cm
Dia. base: 4 cm

Excavation: 1882.
Published: Ljubić 1882, 52, E, no. 39.
Analogies: Is 82b2; Lazar 2003, 188, form 8.6.11.
Date: End of the 1st cent. – 2nd cent.



75. Balzamarij, inv. br. I 1076

Balzamarij niskog spljoštenog tijela. Rub razgrnut prema van i cjevasto savijen prema unutra. Vrat uzak, dug. Dno ravno.

vis.: 10 cm
pr. r.: 2,5 cm
pr.dna: 4 cm

Iskopavanje : 1882. g.
Publicirano: Ljubić 1882, 52, E, br. 32.
Analogije: Is 82b2; Lazar 2003, 188, forma 8.6.11.
Dat.: druga pol. 2. – prva pol. 3. st.

75. Balsamarium, inv. no. I 1076

Balsamarium with a wide flattened body. Rim splayed outwards and tubularly curved inwards. Neck long and narrow. Base flat.

H: 10 cm
Dia. rim: 2.5 cm
Dia. base: 4 cm

Excavation: 1882.
Published: Ljubić 1882, 52, E, no. 32.
Analogies: Lazar 2003, 188, form 8.6.11.
Date: End of the 1st cent. – 2nd cent.

**BALZAMARIJI ŠIROKOG
SPLJOŠTENOG TIJELA S
PROFILACIJOM U
SREDINI**



**76. Balzamarij,
inv. br. I 1063, t. 19: 1.**

Balzamarij širokog, spljoštenog tijela koje je u sredini profilirano. Vrat dug, uzak. Dno jako uvučeno.

vis.: 19,8 cm
pr. dna: 10 cm

Iskopavanje: 1882. g.
Publicirano: Ljubić 1882, 52, E, br. 11–56; Damevski 1976, 65, t. 11: 2.
Analogije: De Tommaso 1990, 71, forma 49; Mandruzzato, Marcante 2007, 97, no. 249.
Dat.: kraj 1. – druga pol. 2. st.

**BALSAMARIA WITH A
WIDE FLATTENED BODY
WITH PROFILING IN THE
MIDDLE**

**76. Balsarium,
inv. no. I 1063, pl. 19: 1.**

Balsarium with a wide flattened body profiled in the middle. Neck long and narrow. Base highly concave.

H: 19.8 cm
Dia. base: 10 cm

Excavation: 1882.
Published: Ljubić 1882, 52, E, no. 11–56; Damevski 1976, 65, pl. 11: 2.
Analogies: De Tommaso 1990, 71, type 49; Mandruzzato, Marcante 2007, 97, no. 249.
Date: end of the 1st cent. – second half of the 2nd cent.

**BALZAMARIJI ŠIROKOG
VRATA I SPLJOŠTENOG
TIJELA**



**77. Balzamarij,
inv. br. I 1025, t. 19: 2.**

Balzamarij niskog spljoštenog tijela i širokog vrata, dno blago uvučeno i na njemu otisak žiga u krugu s natpisom PATRIMONI.

vis.: 4,4 cm
pr. dna: 5,4 cm

Iskopavanje: 1882. g.
Publicirano: Trasparenze 1998,
Analogije: Lazar 2003, 189, forma 8.6.12.; Lazar 2006c, 276, CRO-40; Price 2006, 299, E-UNG 103; Foy, Nenna 2006, pl. 67, 68.
Dat.: 2. st.

**BALSAMARIA WITH A
WIDE NECK AND
FLATTENED BODY**

**77. Balsarium,
inv. no. I 1025, pl. 19: 2.**

Balsarium with a low flattened body and wide neck, base slightly concave with a stamp in a circle with the inscription PATRIMONI.

H: 4.4 cm
Dia. base: 5.4 cm

Excavation: 1882.
Published: Trasparenze 1998,
Analogies: Lazar 2003, 189, form 8.6.12.; Lazar 2006c, 276, CRO-40; Price 2006, 299, E-UNG 103; Foy, Nenna 2006, pl. 67, 68.
Date: 2nd cent.

**78. Balzamarij,
inv. br. I 1034, t. 19: 3.**



Balzamarij širokog spljoštenog tijela i širokog vrata. Rub cjevasto izvijen prema gore. Dno malo uvučeno.

vis.: 6,8 cm
pr. r.: 6 cm
pr.dna: 4 cm

Iskopavanje: 1882. g.
Nije publicirano.
Analogije: Lazar 2003, 189, forma 8.6.12.;
Dat.: 2. st.

**78. Balsarium,
inv. no. I 1034, pl. 19: 3.**

Balsarium with a wide flattened body and wide neck. Rim tubularly curved upwards. Base slightly concave.

H: 6.8 cm
Dia. rim: 6 cm
Dia. base: 4 cm

Excavation: 1882.
Unpublished.
Analogies: Lazar 2003, 189, form 8.6.12.
Date: 2. st.

BALZAMARIJI KUGLASTOG TIJELA



79. Balzamarij, inv. br. I 1321, t. 19: 4.

Balzamarij kuglastog tijela. Rub kratak, razgrnut prema van. Dno ravno.

vis.: 6,8 cm
pr. r.: 1,8 cm
pr. dna: 1 cm

Iskopavanje: 1882. g.
Publicirano: Ljubić 1882, 52, E 57.
Analogije: Is 6; Lazar 2003, 190, forma 8.6.13.; Buljević 2004, 85, forma 3f.
Dat.: prva pol. 1. st.

BALSAMARIA WITH A GLOBULAR BODY

79. Balsarium, inv. no. I 1321, pl. 19: 4.

Balsarium with a globular body. Rim short and everted. Base flat.

H: 6.8 cm
Dia. rim: 1.8 cm
Dia. base: 1 cm

Excavation: 1882.
Published: Ljubić 1882, 52, E 57.
Analogies: Is 6; Lazar 2003, 190, form 8.6.13; Buljević 2004, 85, form 3f.
Date: First half of the 1st cent.



80. Balzamarij, inv. br. I 1322, t. 19: 6.

Balzamarij kuglastog tijela. Rub razgrnut prema van. Vrat profiliran na prelasku u tijelo. Dno blago uvučeno. Staklo blijedo plave boje.

vis.: 7,4 cm
pr. r.: 2 cm
pr. dna: 1,2 cm

Iskopavanje: 1882. g.
Publicirano: Ljubić 1882, 52, E 57.
Analogije: Is 6; Lazar 2003, 190, forma 8.6.13.
Dat.: prva pol. 1. st.

80. Balsarium, inv. no. I 1322, pl. 19: 6.

Balsarium with a globular body. Rim everted. Neck profiled at the transition to the body. Base slightly concave. Pale blue glass.

H: 7.4 cm
Dia. rim: 2 cm
Dia. base: 1.2 cm

Excavation: 1882.
Published: Ljubić 1882, 52, E 57.
Analogies: Is 6; Lazar 2003, 190, form 8.6.13.
Date: First half of the 1st cent.



81. Balzamarij, inv. br. I 1324, t. 19: 5.

Balzamarij kuglastog tijela. Rub razgrnut prema van. Vrat kratak, profiliran na prelasku u tijelo. Dno ravno, staklo dekolorirano.

vis.: 4,6 cm
pr.r.: 1,8 cm
pr. dna: 1 cm

Iskopavanje: 1882. g.
Nije publicirano.
Analogije: Is 6; Lazar 2003, 190, forma 8.6.13.
Dat.: prva pol. 1. st.

81. Balsarium, inv. no. I 1324, pl. 19: 5.

Balsarium with a globular body. Rim everted. Neck short, profiled at the transition to the body. Base flat, glass decolorated.

H: 4.6 cm
Dia. rim: 1.8 cm
Dia. base: 1 cm

Excavation: 1882.
Unpublished.
Analogies: Is 6; Lazar 2003, 190, form 8.6.13.
Date: First half of the 1st cent.



82. Balzamarij,
inv. br. I 1334, t. 19: 7.

Balzamarij kuglastog tijela. Rub horizontalno razgrnut prema van. Vrat kratak, profiliran na prelasku u tijelo. Dno ravno. Staklo jantarne boje.

vis.: 8,2 cm
pr. r.: 2 cm
pr. dna: 2,2 cm

Iskopavanje: 1882. g.
Publicirano: Trasparenze 1998, kat. 33.
Analogije: Is 6; Lazar 2003, 190, forma 8.6.13.
Dat.: prva pol. 1. st.



83. Balzamarij,
inv. br. I 1335, t. 19: 8.

Balzamarij kuglastog tijela. Rub horizontalno izvučen prema van. Vrat kratak. Dno ravno. Staklo svijetlo plave boje.

vis.: 6 cm
pr. r.: 1,6 cm
pr. dna: 2,4 cm

Iskopavanje: 1882. g.
Publicirano: Arte cultura, kat. 170; Trasparenze 1998, kat. 37.
Analogije: Is 6; Lazar 2003, 190, forma 8.6.13.
Dat.: prva pol. 1. st.



84. Balzamarij, inv. br. I 1035

Balzamarij kuglastog tijela. Rub jako izvučen prema van. Vrat cilindričan, profiliran na prelasku u tijelo. Dno ravno.

vis.: 8,9 cm
pr. r.: 2,8 cm
pr. dna: 1,5 cm

Nema podataka o iskopavanju.
Nije publicirano.
Analogije: Is 6; Lazar 2003, 190, forma 8.6.13.
Dat.: prva pol. 1. st.



85. Balzamarij, inv. br. I 1054

Balzamarij kuglastog tijela. Rub izvučen horizontalno prema van. Vrat dug. Dno oblo.

vis.: 10,6 cm
pr.r.: 2,8 cm
pr. dna: 2,5 cm

Iskopavanje: 1882. g.
Publicirano: Ljubić 1882, 52 E, br. 58.
Analogije: Is 6; Lazar 2003, 190, forma 8.6.13.
Dat.: prva pol. 1. st.

82. Balsamarium,
inv. no. I 1334, pl. 19: 7.

Balsamarium with a globular body. Rim horizontally splayed outwards. Neck short, profiled at the transition to the body. Base flat. Amber glass.

H: 8.2 cm
Dia. rim: 2 cm
Dia. base: 2.2 cm

Excavation: 1882.
Published: Trasparenze 1998, cat. no. 33
Analogies: Is 6; Lazar 2003, 190, form 8.6.13.
Date: First half of the 1st cent.

83. Balsamarium,
inv. no. I 1335, pl. 19: 8.

Balsamarium with a globular body. Rim horizontally everted. Neck short. Base flat. Pale blue glass.

H: 6 cm
Dia. rim: 1.6 cm
Dia. base: 2.4 cm

Excavation: 1882.
Published: Arte cultura 1993, cat. no. 170; Trasparenze 1998, cat. no. 37.
Analogies: Is 6; Lazar 2003, 190, form 8.6.13.
Date: First half of the 1st cent.

84. Balsamarium, inv. no. I 1035

Balsamarium with a globular body. Rim strongly everted outwards. Neck cylindrical, profiled at the transition to the body. Base flat.

H: 8.9 cm
Dia. rim: 2.8 cm
Dia. base: 1.5 cm

No data about excavation.
Unpublished.
Analogies: Is 6; Lazar 2003, 190, form 8.6.13.
Date: First half of the 1st cent.

85. Balsamarium, inv. no. I 1054

Balsamarium with a globular body. Rim everted outwards. Neck long. Base rounded.

H: 10.6 cm
Dia. rim: 2.8 cm
Dia. base: 2.5 cm

Excavation: 1882.
Published: Ljubić 1882, 52 E, no. 58.
Analogies: Is 6; Lazar 2003, 190, form 8.6.13.
Date: First half of the 1st cent.



86. Balzamarij, inv. br. I 1320

Balzamarij kuglastog tijela, nedostaje rub. Vrat profiliran na prelasku u tijelo. Dno blago uvučeno, staklo dekolirano.

vis.: 5,5 cm
pr. dna: 1,6 cm

Iskopavanje: 1882. g.
Publicirano: Ljubić 1882, 52, E 57.
Analogije: Is 6; Lazar 2003, 190, forma 8.6.13.
Dat.: prva pol. 1. st.

86. Balsamarium, inv. no. I 1320

Balsamarium with a globular body. Rim missing. Neck profiled at the transition to the body. Base slightly concave, glass decolorized.

H: 5.5 cm
Dia. base: 1.6 cm

Excavation: 1882.
Published: Ljubić 1882, 52, E 57.
Analogies: Is 6; Lazar 2003, 190, form 8.6.13.
Date: First half of the 1st cent.



87. Balzamarij, inv. br. I 1323

Balzamarij kuglastog tijela, nedostaje rub. Vrat kratak, profiliran na prelasku u tijelo. Dno ravno, staklo mutno.

vis.: 5,7 cm
pr. dna: 1,2 cm

Iskopavanje: 1882. g.
Nije publicirano.
Analogije: Is 6; Lazar 2003, 190, forma 8.6.13.;
Dat.: prva pol. 1. st.

87. Balsamarium, inv. no. I 1323

Balsamarium with a globular body. Rim missing. Neck short, profiled at the transition to the body. Base flat, glass opaque.

H: 5.7 cm
Dia. base: 1.2 cm

Excavation: 1882.
Unpublished.
Analogies: Is 6; Lazar 2003, 190, form 8.6.13.
Date: First half of the 1st cent.



88. Balzamarij, inv. br. I 2032

Balzamarij kuglastog tijela. Vrat kratak, profiliran na prelasku u tijelo. Dno ravno.

vis.: 4,7 cm
pr. r.: 1,8 cm
pr. dna: 1,2 cm

Iskopavanje: 1882. g.
Nije publicirano.
Analogije: Is 6; Lazar 2003, 190, forma 8.6.13.
Dat.: prva pol. 1. st.

88. Balsamarium, inv. no. I 2032

Balsamarium with a globular body. Neck short, profiled at the transition to the body. Base flat.

H: 4.7 cm
Dia. rim: 1.8 cm
Dia. base: 1.2 cm

Excavation: 1882.
Unpublished.
Analogies: Is 6; Lazar 2003, 190, form 8.6.13.
Date: First half of the 1st cent.

**BALZAMARIJI
KUGLAŠTOG TIJELA
I SPLJOŠTENOG RUBA**



**89. Balzamarij,
inv. br. I 1055, t. 20: 1.**

Balzamarij kuglastog tijela. Rub horizontalno izvučen prema van, cjevasto savijen prema gore i spljošten. Vrat širok, na prelasku u tijelo profiliran. Dno ravno.

vis.: 15,4 cm
pr. r.: 4,4 cm
pr. dna: 3,4 cm

Nema podataka o iskopavanju.
Publicirano: Damevski 1976, 63, t. 1: 5.
Analogije: Lazar 2003, 190, forma 8.6.14.
Dat.: 2. – 3. st.

**BALSAMARIA WITH A
GLOBULAR BODY AND
FLATTENED RIM**

**89. Balsarium,
inv. no. I 1055, pl. 20: 1.**

Balsarium with a globular body. Rim horizontally everted, tubularly curved upwards, and flattened. Neck wide, profiled at the transition to the body. Base flat.

H: 15.4 cm
Dia. rim: 4.4 cm
Dia. base: 3.4 cm

No data about excavation.
Published: Damevski 1976, 63, pl. 1: 5.
Analogies: Lazar 2003, 190, form 8.6.14.
Date: 2nd – 3rd cent.

**BALZAMARIJI
PIRIFORMNOG TIJELA S
RAVNO ODREZANIM
RUBOM**



**90. Balzamarij,
inv. br. I 1332, t. 20: 2.**

Balzamarij piriformnog tijela. Vrat uzak, cilindričan. Dno blago uvučeno. Staklo tamno plave boje.

vis.: 8 cm
pr. r.: 1 cm
pr. dna: 3,2 cm

Iskopavanje: 1882. g.
Nije publicirano.
Analogije: De Tommaso 1990, 63, forma 38; Buljević 2004, 85, forma 3h.
Dat.: 1. st.

**BALSAMARIA WITH
A PYRIFORM BODY AND A
CUT-OFF RIM**

**90. Balsarium,
inv. no. I 1332, pl. 20: 2.**

Balsarium with a pear-shaped body. Neck narrow and cylindrical. Base slightly concave. Dark blue glass.

H: 8 cm
Dia. rim: 1 cm
Dia. base: 3.2 cm

Excavation: 1882.
Unpublished.
Analogies: De Tommaso 1990, 63, type 38; Buljević 2004, 85, form 3h.
Date: 1st cent.



**91. Balzamarij,
inv. br. I 1325, t. 20: 3.**

Balzamarij piriformnog tijela. Rub razgrnut prema van. Vrat kratak. Dno ravno.

vis.: 7,4 cm
pr. r.: 1,6 cm
pr. dna: 3 cm

Iskopavanje: 1882. g.
Nije publicirano.
Analogije: De Tommaso 1990, 63, forma 38; Buljević 2004, 85, forma 3h.
Dat.: 1. st.

**91. Balsarium,
inv. no. I 1325, pl. 20: 3.**

Balsarium with a pear-shaped body. Rim everted. Neck short. Base flat.

H: 7.4 cm
Dia. rim: 1.6 cm
Dia. base: 3 cm

Excavation: 1882.
Unpublished.
Analogies: De Tommaso 1990, 63, type 38; Buljević 2004, 85, form 3h.
Date: 1st cent.



92. Balzamarij,
inv. br. I 1333, t. 20: 4.

Balzamarij piriformnog tijela. Rub izvučen prema van. Vrat cilindričan. Dno ravno. Staklo ljubičasto.

vis.: 10,8 cm
pr. r.: 1,4 cm
pr. dna: 2,6 cm

Iskopavanje: 1882. g.
Publicirano: Trasprenze 1998, 105, kat. 30.
Analogije: De Tommaso 1990, 63, forma 38; Buljević 2004, 85, forma 3h.
Dat.: 1. st.

92. Balsamarium,
inv. no. I 1333, pl. 20: 4.

Balsamarium with a pear-shaped body. Rim everted. Neck cylindrical. Base flat. Purple glass.

H: 10.8 cm
Dia. rim: 1.4 cm
Dia. base: 2.6 cm

Excavation: 1882.
Published: Trasprenze 1998, 105, cat. no. 30.
Analogies: De Tommaso 1990, 63, type 38; Buljević 2004, 85, form 3h.
Date: 1st cent.



93. Balzamarij,
inv. br. I 1082, t. 20: 5.

Balzamarij piriformnog tijela. Rub razgrnut prema van. Vrat kratak. Dno blago uvučeno. Staklo tamno plave boje.

vis.: 3,6 cm
pr. r.: 1,2 cm
pr. dna: 1 cm

Nema podataka o iskopavanju.
Nije publicirano.
Analogije: De Tommaso 1990, 63, forma 38; Buljević 2004, 85, forma 3h.
Dat.: 1. st.

93. Balsamarium,
inv. no. I 1082, pl. 20: 5.

Balsamarium with a pear-shaped body. Rim everted. Neck short. Base slightly concave. Dark blue glass.

H: 3.6 cm
Dia. rim: 1.2 cm
Dia. base: 1 cm

No data about excavation.
Unpublished.
Analogies: De Tommaso 1990, 63, type 38; Buljević 2004, 85, form 3h.
Date: 1st cent.



94. Balzamarij, inv. br. I 1058

Balzamarij piriformnog tijela, rub nedostaje. Vrat širok, cilindričan. Dno ravno.

vis.: 13 cm
pr. dna: 5,4 cm

Nema podataka o iskopavanju.
Nije publicirano.
Analogije: De Tommaso 1990, 63, forma 38; Buljević 2004, 85, forma 3h.
Dat.: 1. st.

94. Balsamarium, inv. no. I 1058

Balsamarium with a pear-shaped body. Rim missing. Neck wide and cylindrical. Base flat.

H: 13 cm
Dia. base: 5.4 cm

No data about excavation.
Unpublished.
Analogies: De Tommaso 1990, 63, type 38; Buljević 2004, 85, form 3h.
Date: 1st cent.

**BALZAMARIJI
PIRIFORMNOG TIJELA I S
UREZANIM LINIJAMA**



**95. Balzamarij,
inv. br. I 1326, t. 20: 6.**

Balzamarij kruškolikog tijela. Rub horizontalno razgrnut prema van, cjevasto savijen prema unutra. Dno ravno. Na tijelu dvije urezane vodoravne linije.

vis.: 6,2 cm
pr. r.: 1,78cm
pr. dna: 1,2 cm

Iskopavanje: 1882. g.
Nije publicirano.
Analogije: Is 26a; Whitehouse 1997, no. 380; Buljević 2004, 85, no. 53; Mandruzzatto, Marcante 2007, 93, no. 226.
Dat.: druga pol. 1. st.

**BALSAMARIA WITH A
PYRIFORM BODY AND
WITH INCISED LINES**

**95. Balsarium,
inv. no. I 1326, pl. 20: 6.**

Balsarium with a pear-shaped body. Rim horizontally everted, tubularly bent inwards. Base flat. Two incised horizontal lines on the body.

H: 6.2 cm
Dia. rim: 1.78cm
Dia. base: 1.2 cm

Excavation: 1882.
Unpublished.
Analogies: Is 26a; Whitehouse 1997, no. 380; Buljević 2004, 85, no. 53; Mandruzzatto, Marcante 2007, 93, no. 226.
Date: Second half of the 1st cent.

**BALZAMARIJI
ZVONOLIKOG TIJELA**



**96. Balzamarij,
inv. br. I 1057, t. 21: 1.**

Balzamarij zvonolikog tijela. Vrat dug, uzak, cilindričan, na prelasku u tijelo profiliran. Dno uvučeno.

vis.: 18,2 cm
pr. dna: 5 cm

Nema podataka o iskopavanju.
Nije publicirano.
Analogije: Damevski 1976, 83, t. 11: 3; Gluščević 2000, 186, fig. 2; Lazar 2003, forma 8.6.17.
Dat.: 2. – 3. st.

**BALSAMARIA WITH
A BELL-SHAPED BODY**

**96. Balsarium,
inv. no. I 1057, pl. 21: 1.**

Balsarium with a bell-shaped body. Neck long, narrow, cylindrical, profiled at the transition to the body. Base concave.

H: 18.2 cm
Dia. base: 5 cm

No data about excavation.
Unpublished.
Analogies: Damevski 1976, 83, pl. 11: 3; Gluščević 2000, 186, fig. 2; Lazar 2003, form 8.6.17.
Date: 2nd – 3rd cent.

**BALZAMARIJI
S NABORIMA**



**97. Balzamarij,
inv. br. I 1024, t. 21: 2.**

Balzamarij s naborima. Rub cjevasto savijen prema unutra. Vrat kratak, širok. Tijelo četvrtasto sa četiri udubljenja. Dno uvučeno.

vis.: 9,4 cm
pr. r.: 3,6 cm
pr. dna: 2 cm

**BALSAMARIA WITH
INDENTATIONS**

**97. Balsarium,
inv. no. I 1024, pl. 21: 2.**

Balsarium with indentations. Rim tubularly curved inwards. Neck short and wide. Body square with four indentations. Base concave.

H: 9.4 cm
Dia. rim: 3.6 cm
Dia. base: 2 cm

Nema podataka o iskopavanju.
Nije publicirano.
Analogije: Mandruzzoato, Marcante 2007, 101, no. 273.
Dat.: prva pol. 3. st.

No data about excavation.
Unpublished.
Analogies: Mandruzzoato, Marcante 2007, 101, no. 273.
Date: first half of the 3rd cent.

BALZAMARIJI VRETNASTOG TIJELA



98. Balzamarij, inv. br. I 1339, t. 21: 3.

Balzamarij vretenastog tijela. Rub široko horizontalno izvučen prema van, cjevasto savijen prema unutra. Vrat dug, uzak. Tijelo s jače naglašenim ramenima, prema dnu se sužava. Dno na sredini uvučeno.

vis.: 10,8 cm
pr. r.: 3,2 cm
pr. dna: 1,6 cm

Iskopavanje: 1882. g.
Publicirano: Ljubić 1882, 52, E 64.
Analogije: Buljević 2004, 86, sl. 4: 76.
Dat.: 3. st. ?

BALSAMARIA WITH A SPINDLE-SHAPED BODY

98. Balsamarium, inv. no. I 1339, pl. 21: 3.

Balsamarium with a spindle-shaped body. Rim widely splayed outwards and tubularly curved inwards. Neck long and narrow. Body with strongly emphasized shoulders, narrowing to the base. Base concave in the middle.

H: 10.8 cm
Dia. rim: 3.2 cm
Dia. base: 1.6 cm

Excavation: 1882.
Published: Ljubić 1882, 52, E 64.
Analogies: Buljević 2004, 86, fig. 4: 76.
Date: 3rd cent.?

BALZAMARIJI DORAĐENI NA TOCILU



99. Balzamarij, inv. br. I 1087, t. 20: 7.

Balzamarij kruškolikog tijela. Rub horizontalno izvučen prema van. Vrat kratak, cilindričan. Dno ravno. Staklo deblje, tamno plavo, mutno. Na površini vidljive horizontalne linije – tragovi dorade na tocilu.

vis.: 8,4 cm
pr. r.: 2 cm
pr. dna: 2,4 cm

Nema podataka o iskopavanju.
Publicirano: Damevski 1976, 75, t. 3: 1; Trasprenze 1998, kat. 27.
Analogije: Mandruzzoato, Marcante 2007, 58, no. 15.
Dat.: kraj 1. st. pr. Kr. – početak 1 st.

BALSAMARIA FINISHED ON A LATHE

99. Balsamarium, inv. no. I 1087, pl. 20: 7.

Balsamarium with a pear-shaped body. Rim horizontally splayed outwards. Neck short and cylindrical. Base flat. Glass thick and dark blue. Visible thin horizontal lines on the body – traces of final working on a lathe.

H: 8.4 cm
Dia. rim: 2 cm
Dia. base: 2.4 cm

No data about excavation.
Published: Damevski 1976, 75, pl. 3: 1; Trasprenze 1998, cat. no. 27
Analogies: Mandruzzoato, Marcante 2007, 58, no. 15.
Date: end of the 1st cent. BCE – first half of the 1st cent. CE

Table Plates

crteži / Drawings

M = 1:2

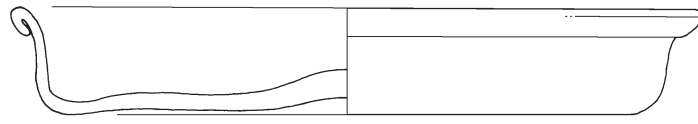

1



2

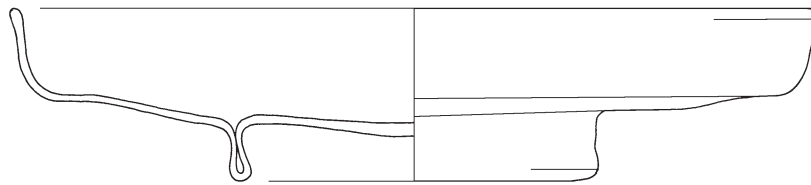

3

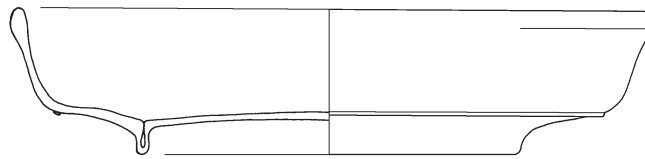

4

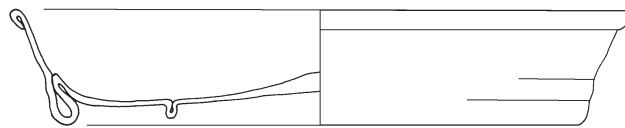

5

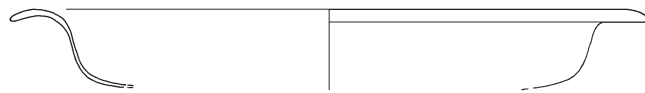

6

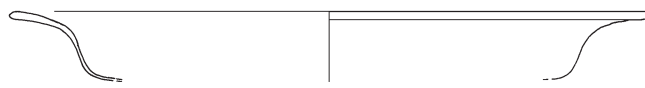

7

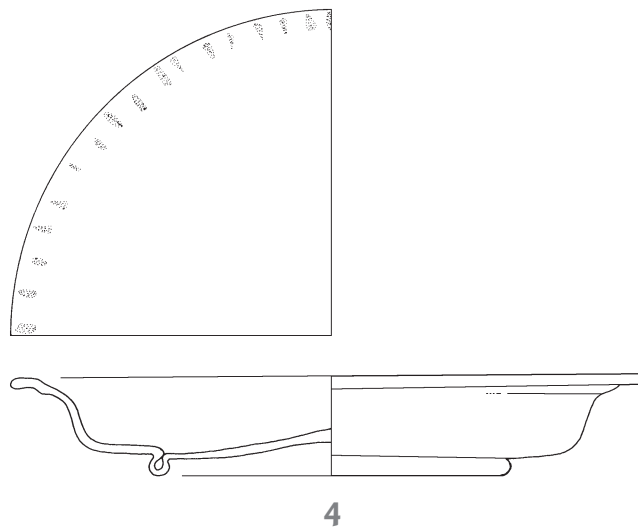
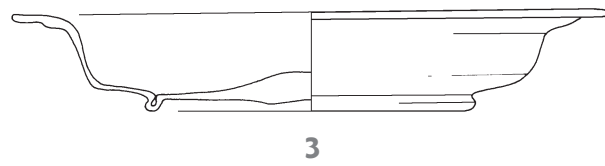
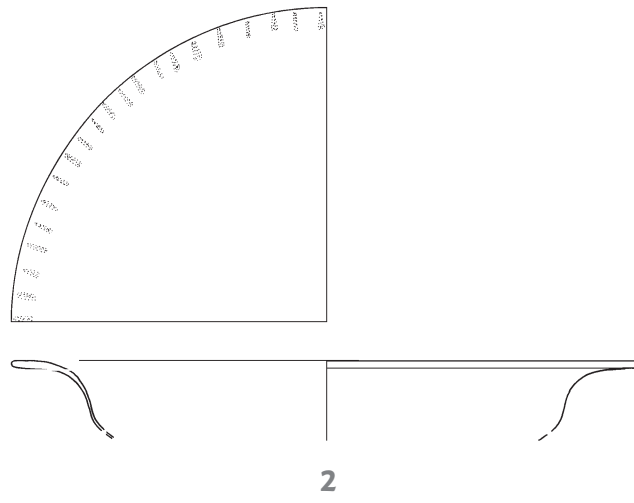
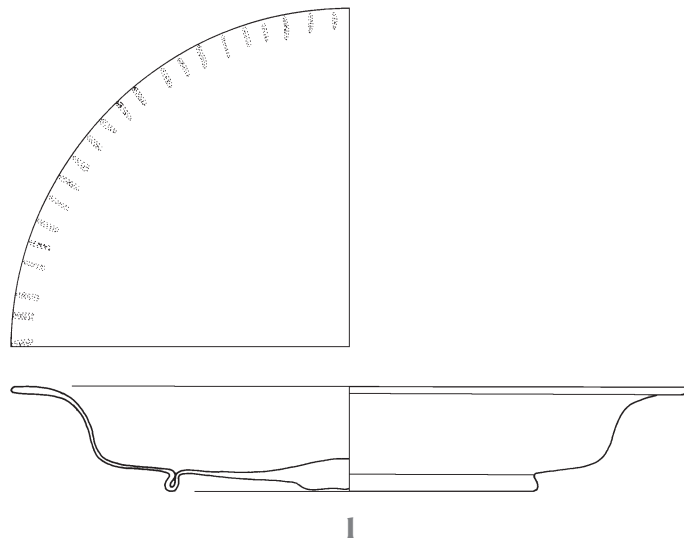

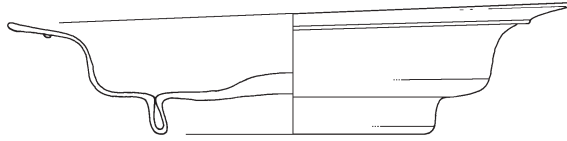

1

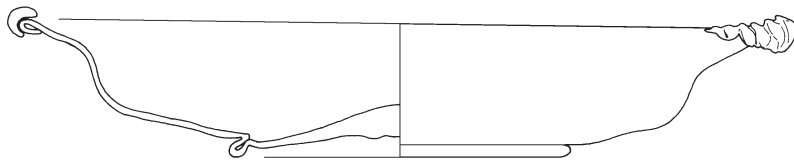

2

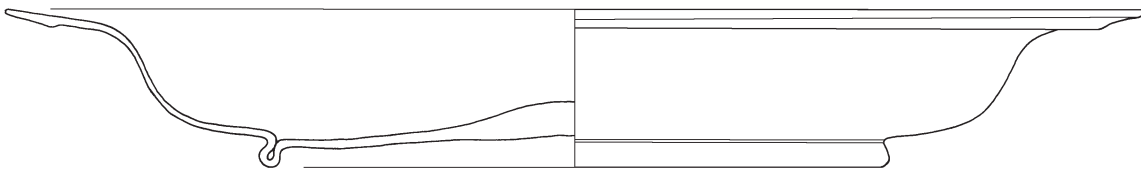

3

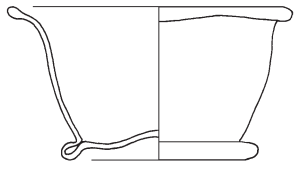

1

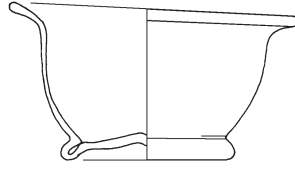

2

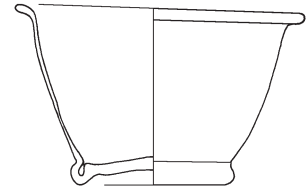

3

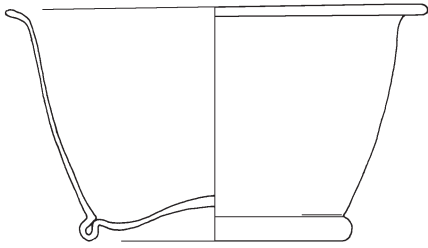

4

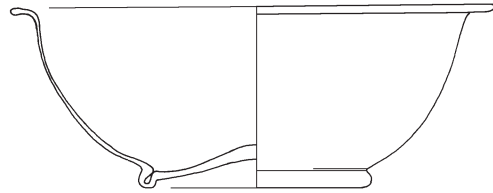

5

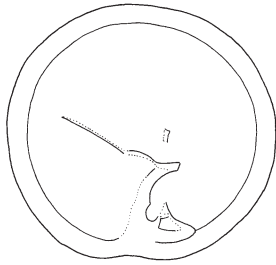

6

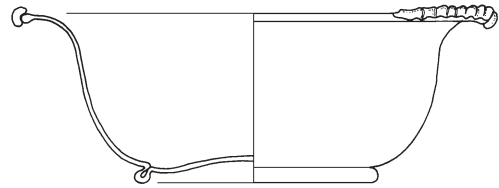

7

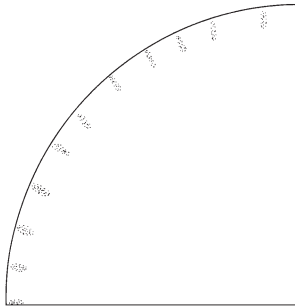

8

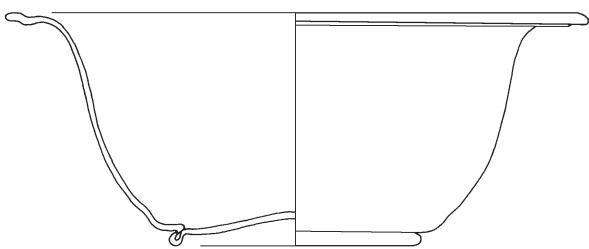

9

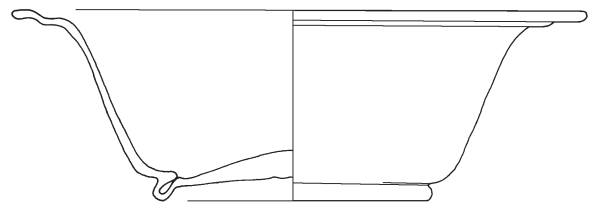

10

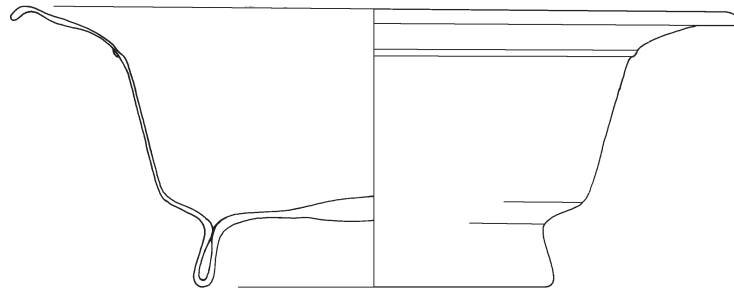

1

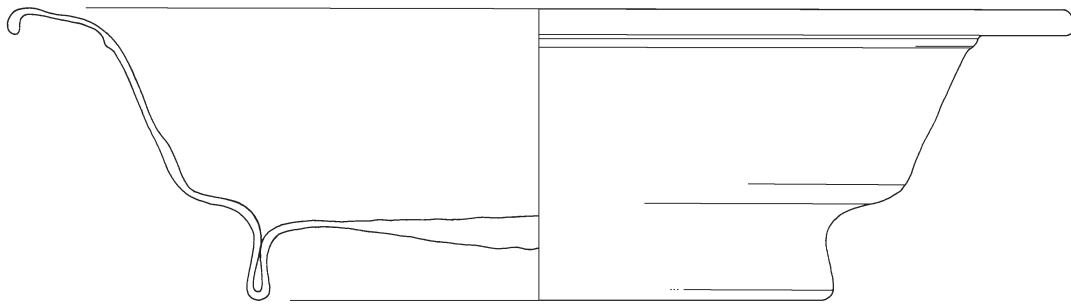

2

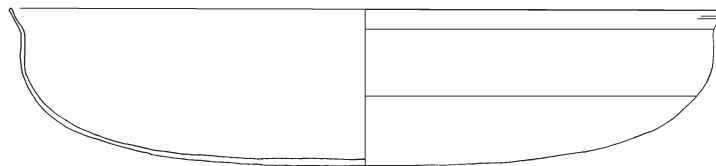

3



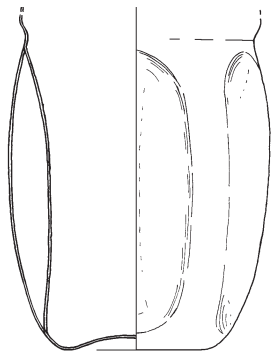

1

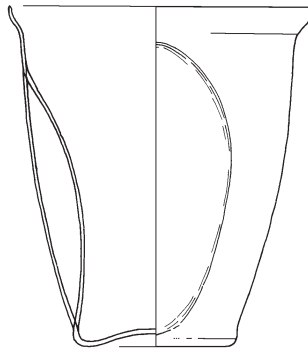

2

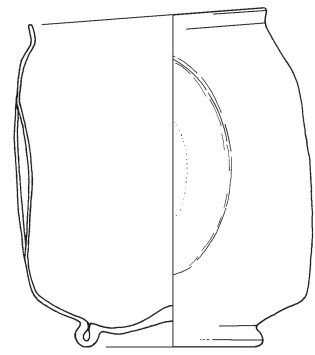

3

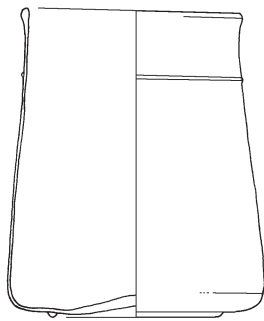

4

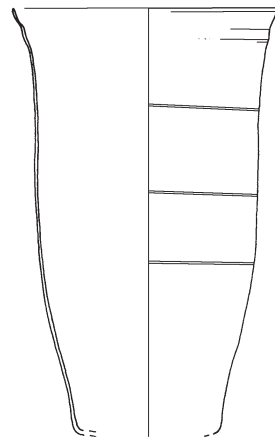

5

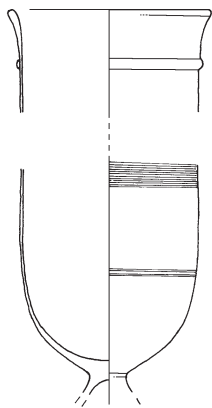

6

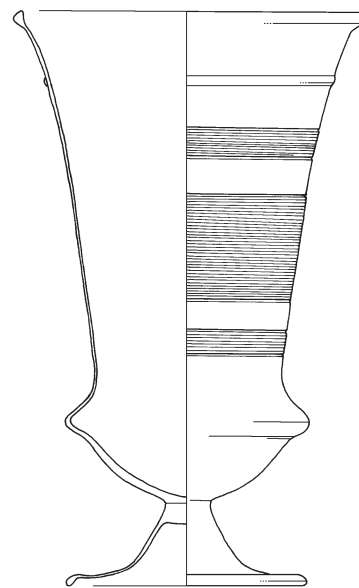

7

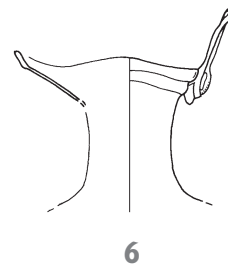
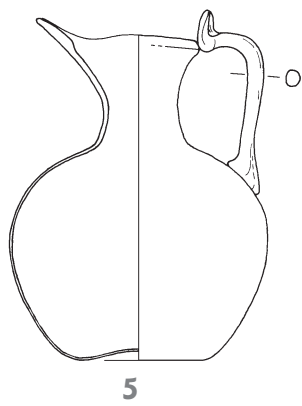
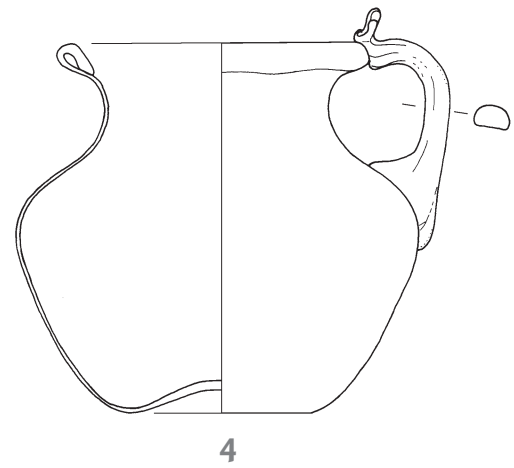
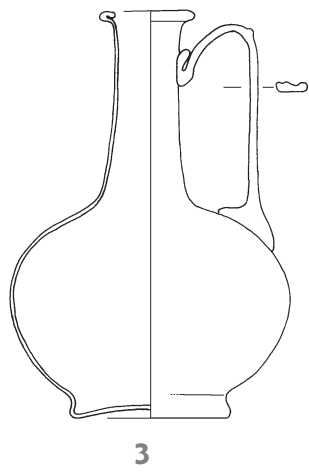
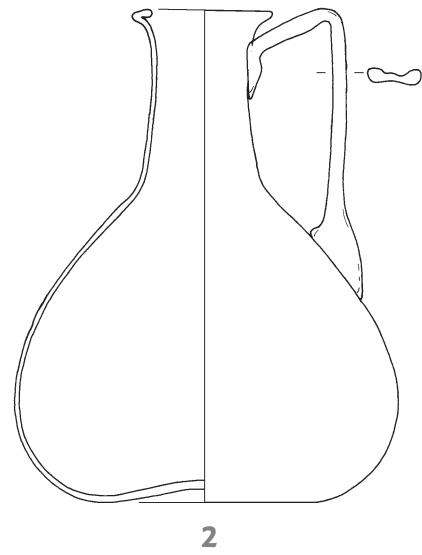
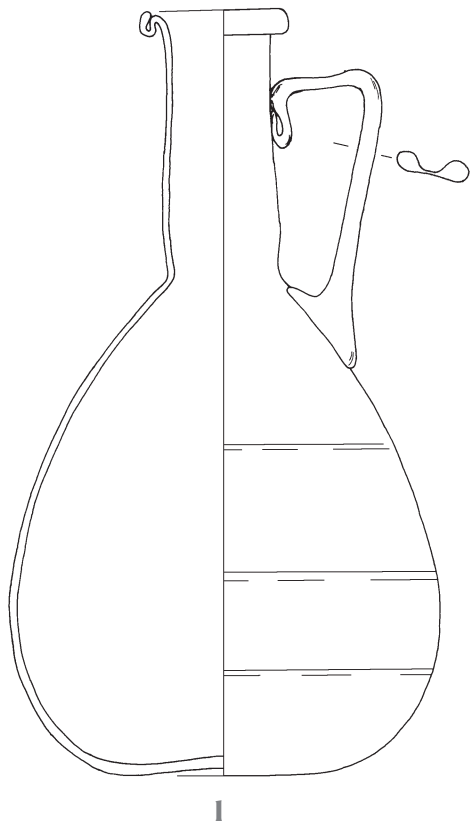

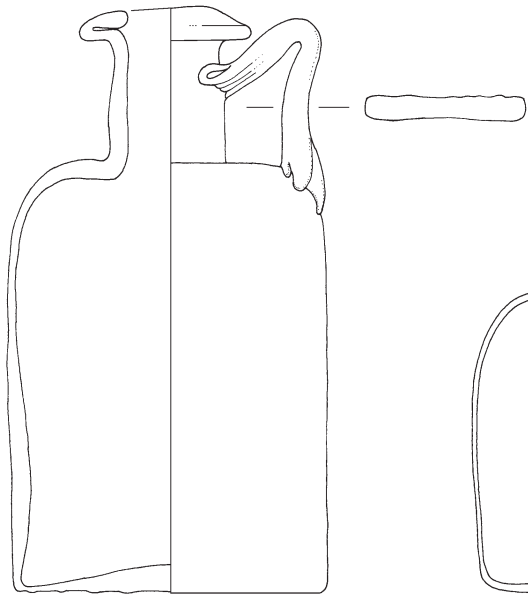

1

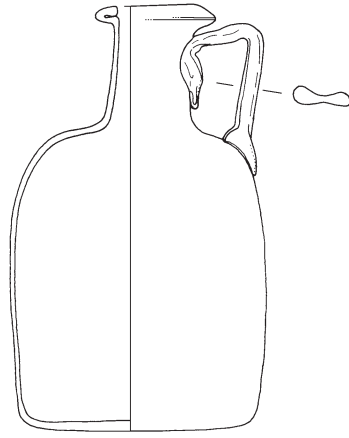

2

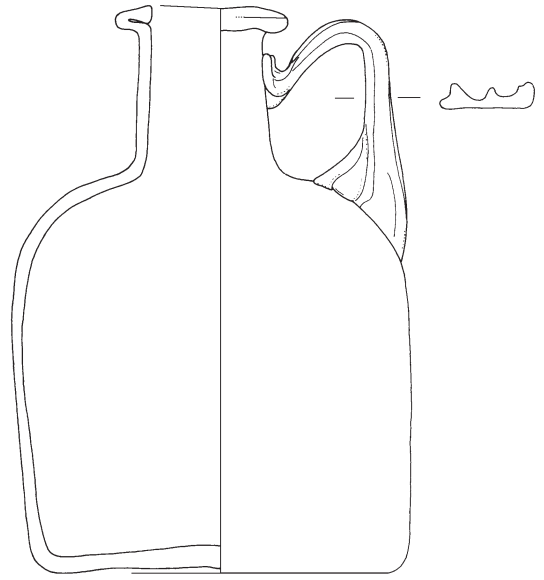

3



4

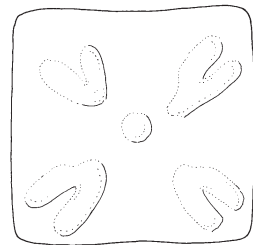
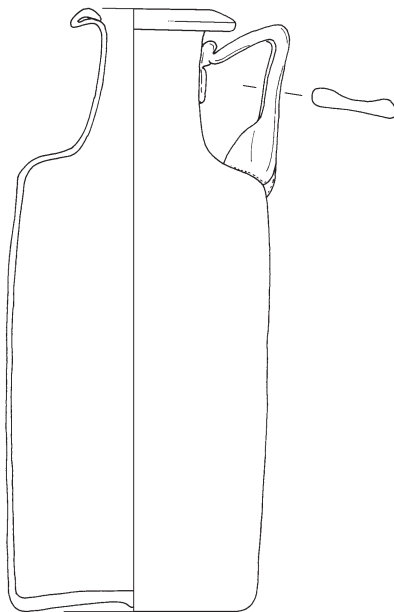

5

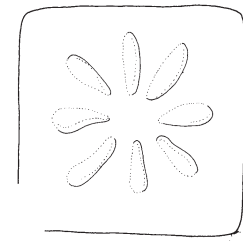
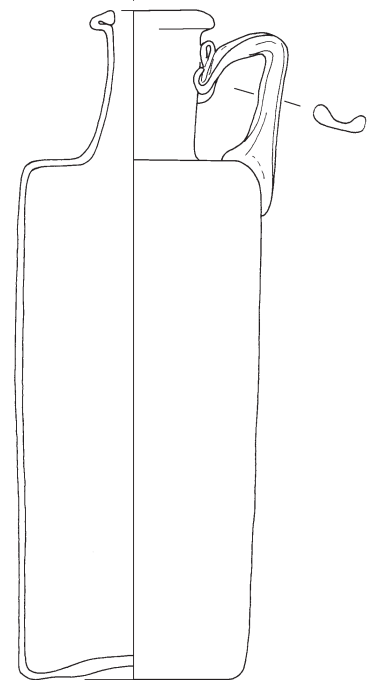

6

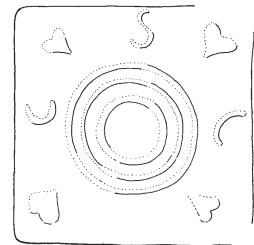
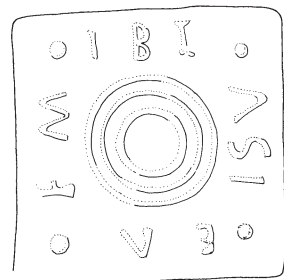
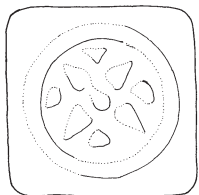
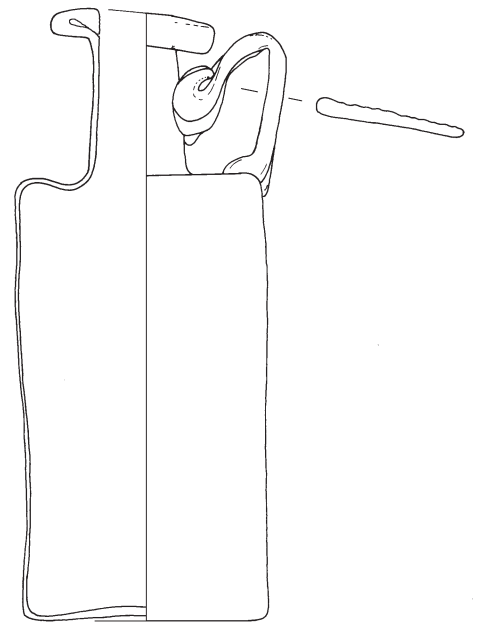
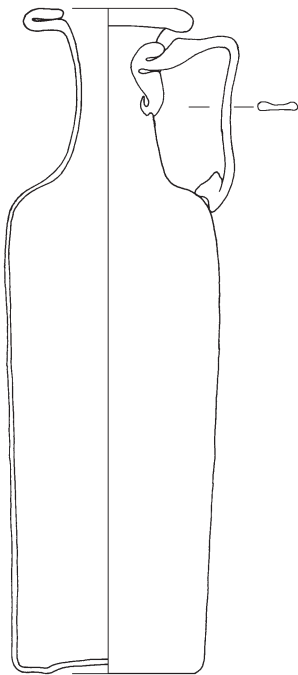
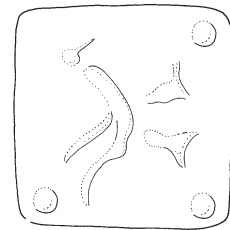
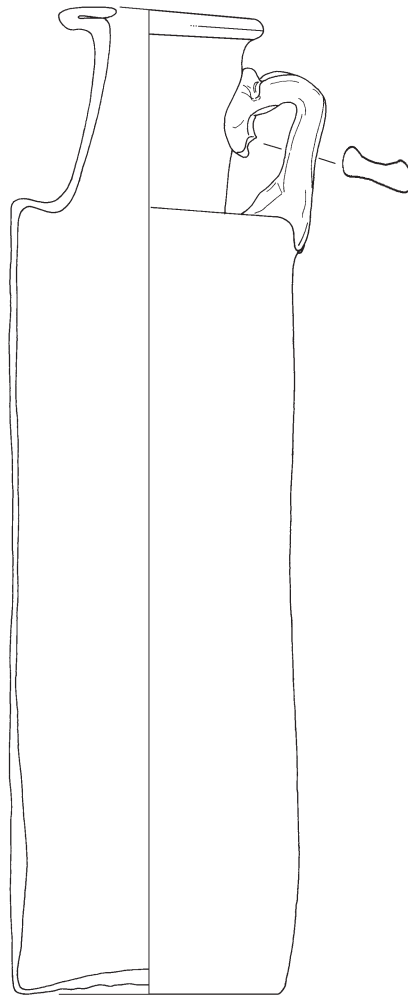
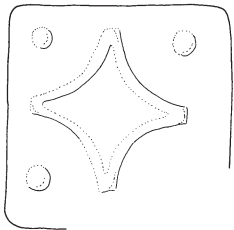
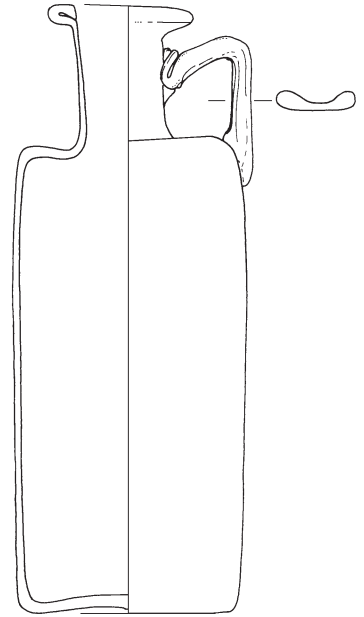
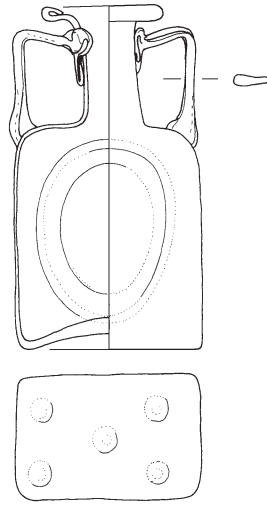
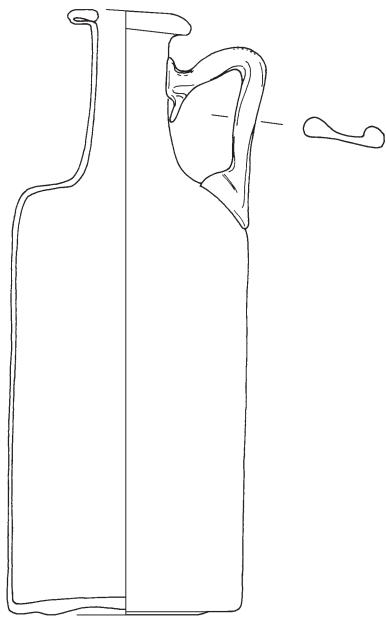

1

2

3

4

5

6

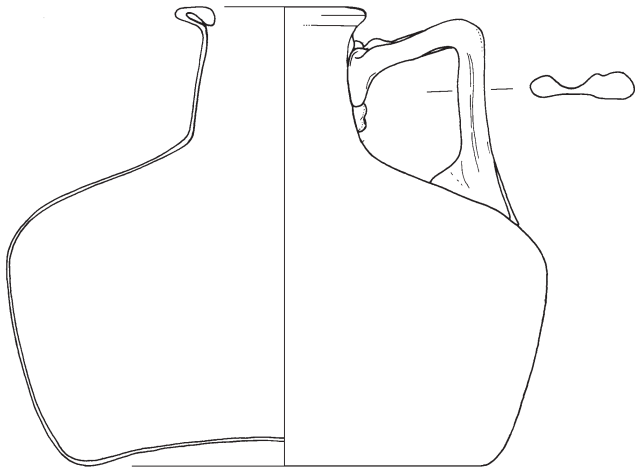

1

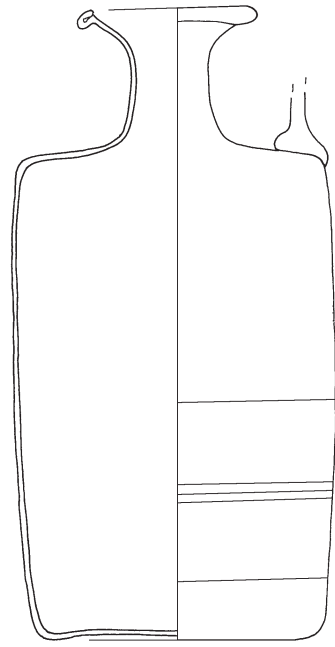

2

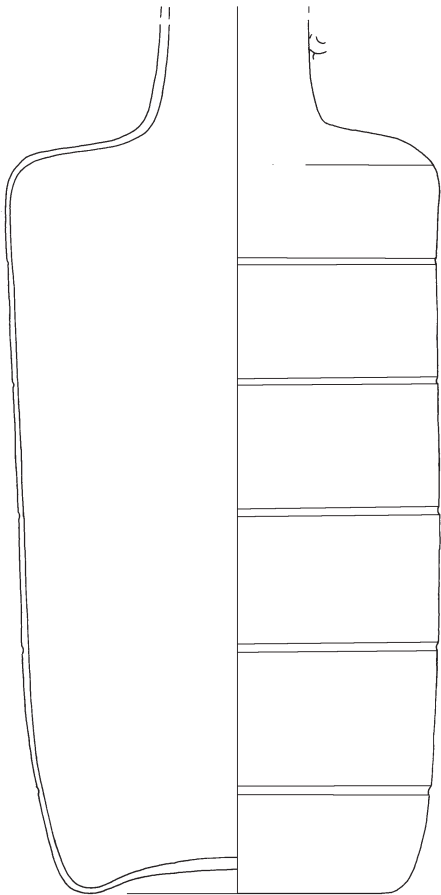

3

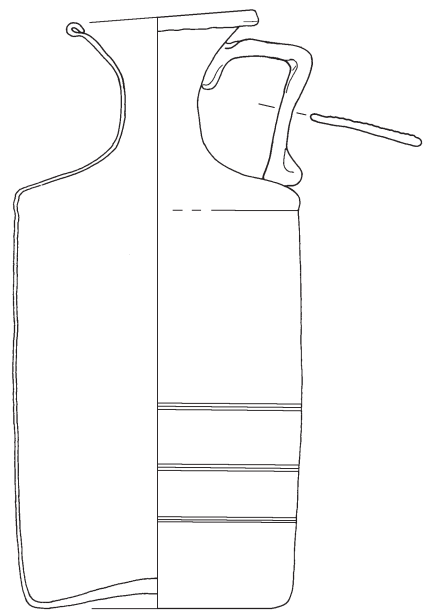

4

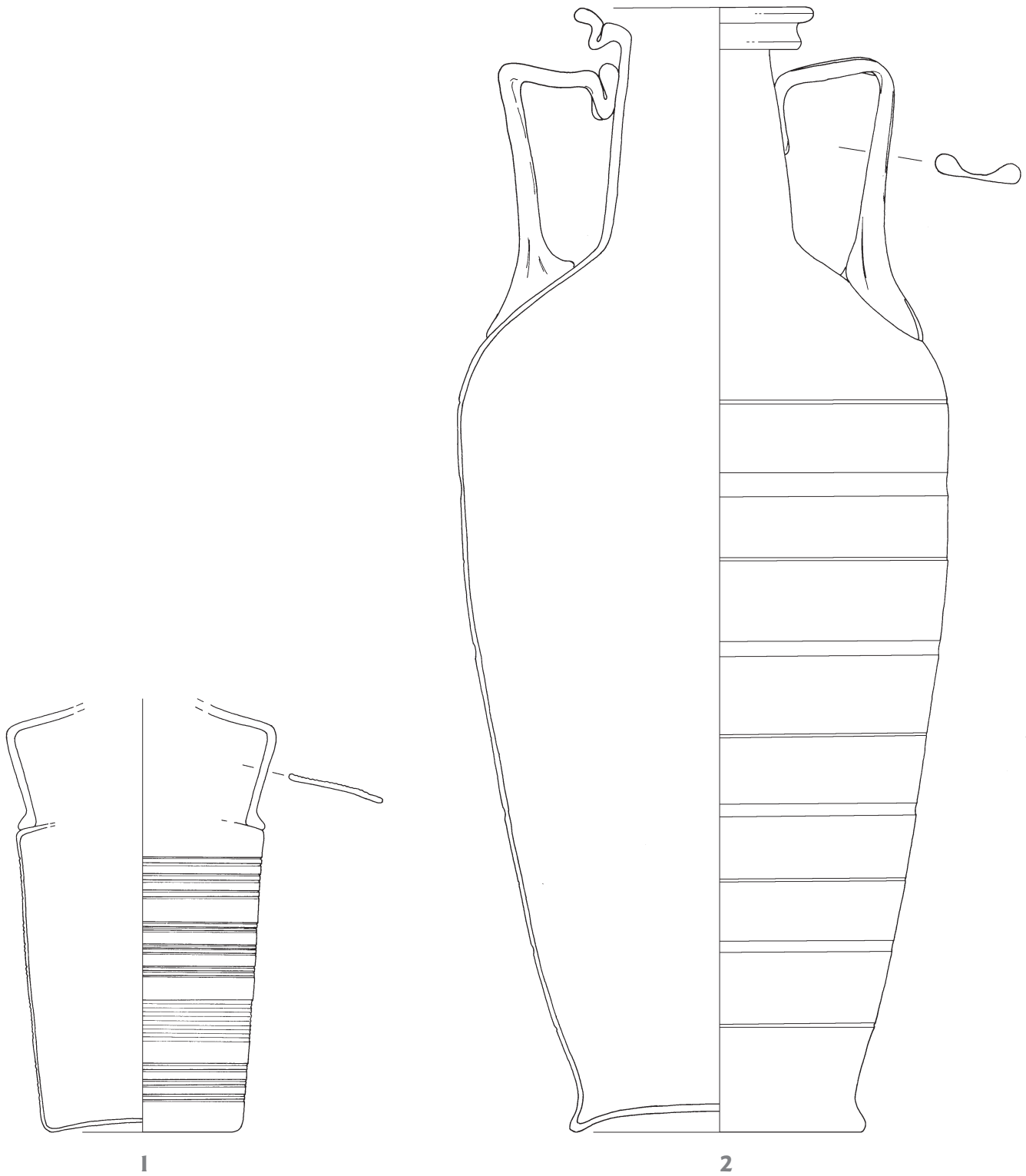

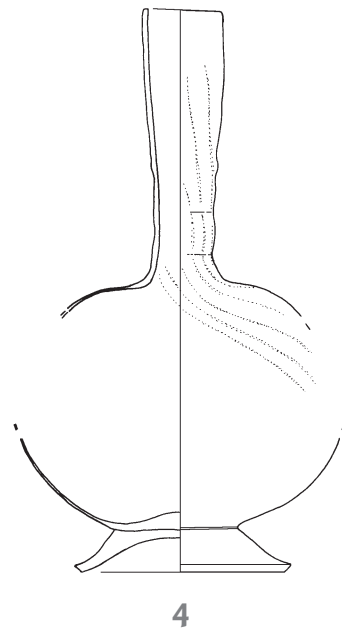
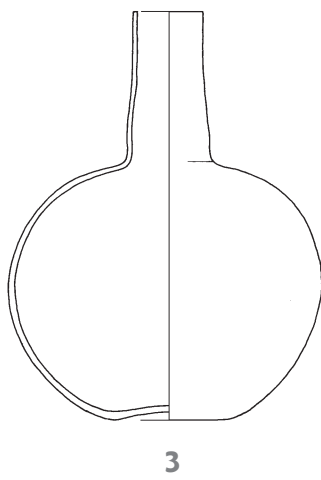
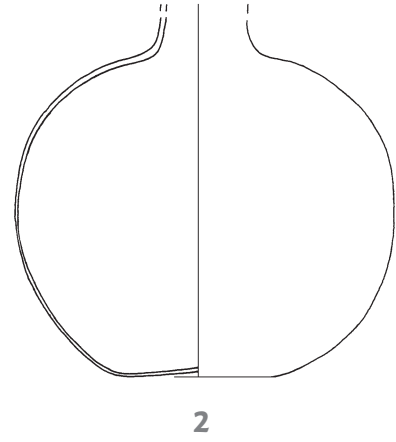
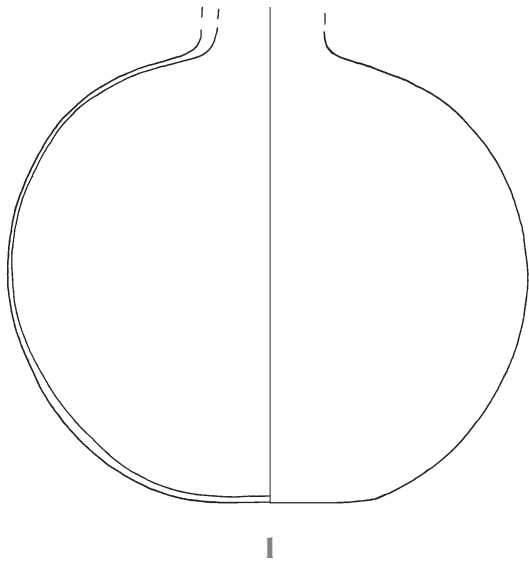

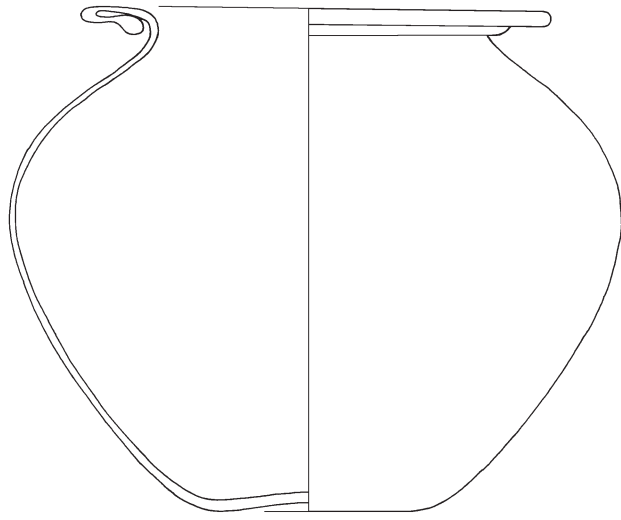

1

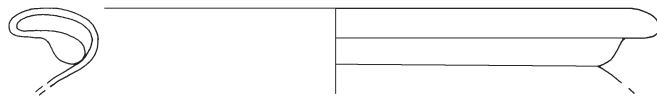

2

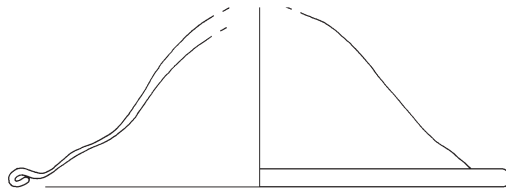

3

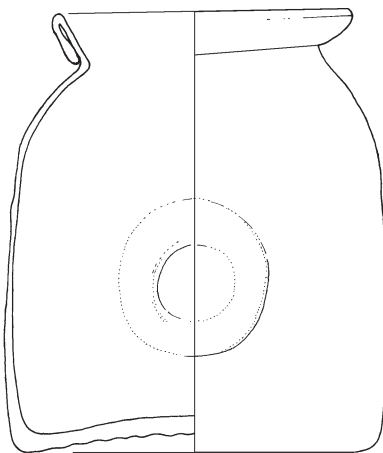

4

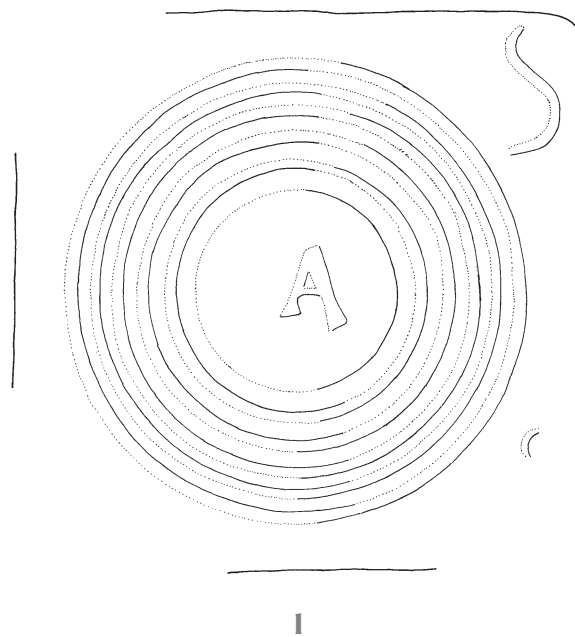
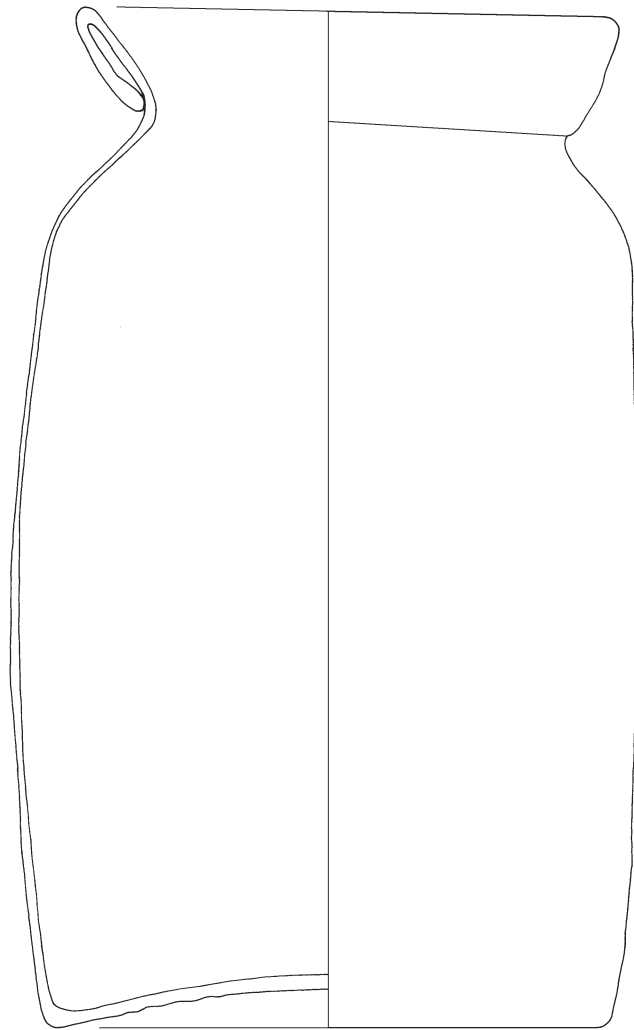

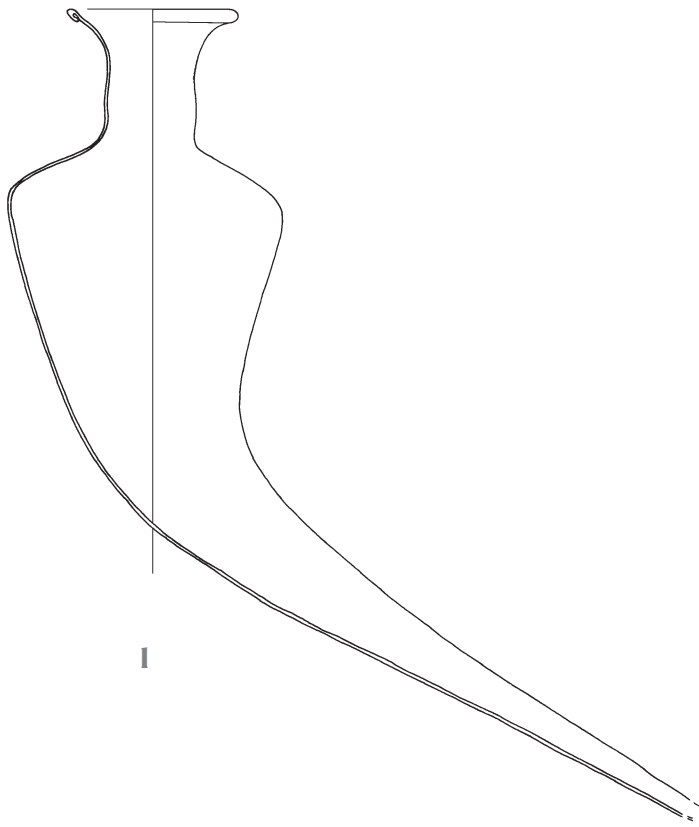

1

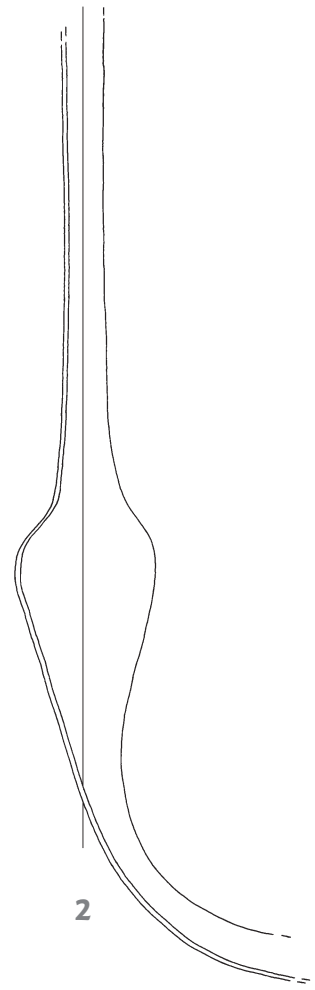

2



3

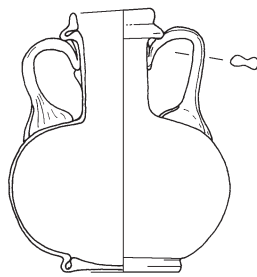

4

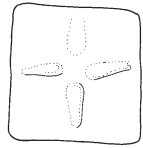
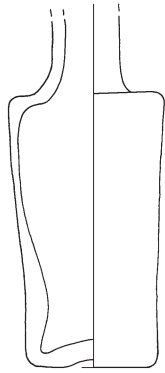

1

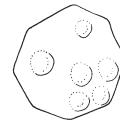
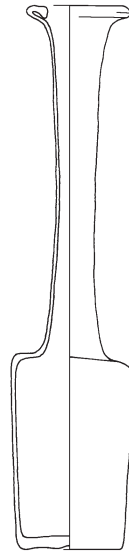

2

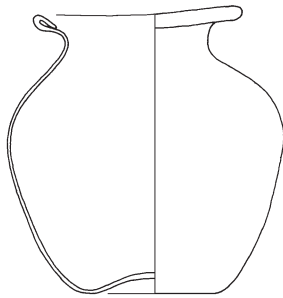

3

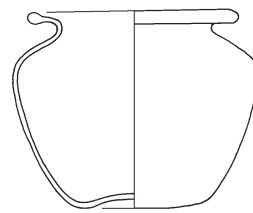

4

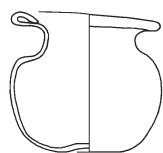

5

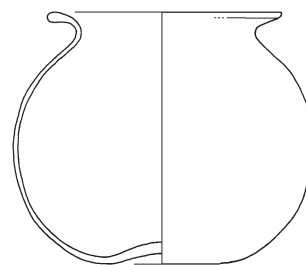

6

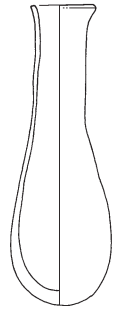

1



2

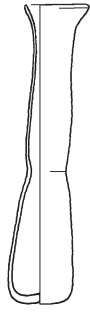

3



4

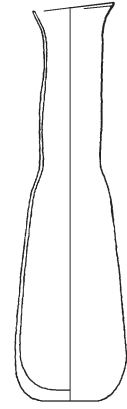

5



6

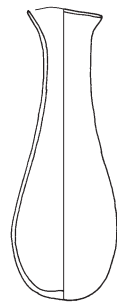

7

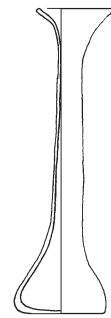

8

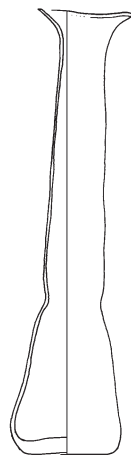

9

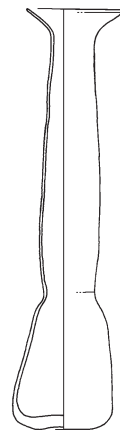

10

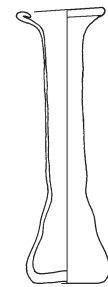

11

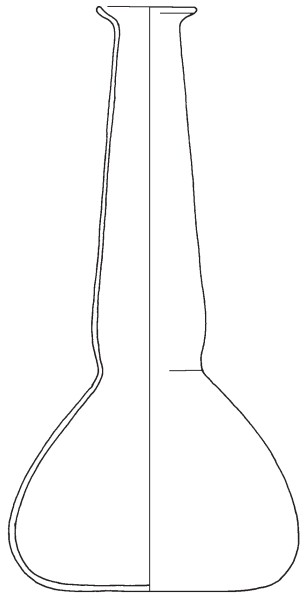

1

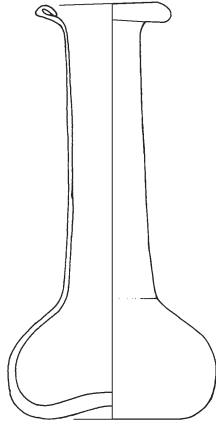

2

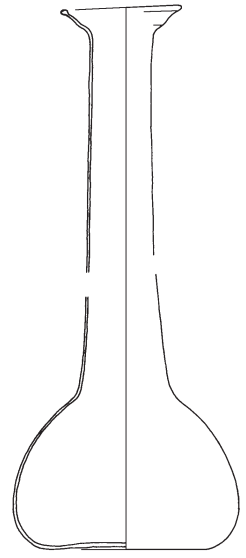

3

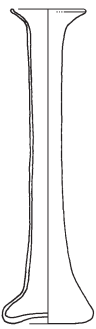

4

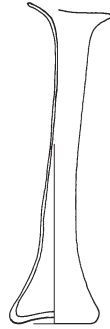

5

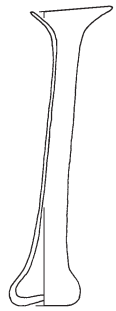

6

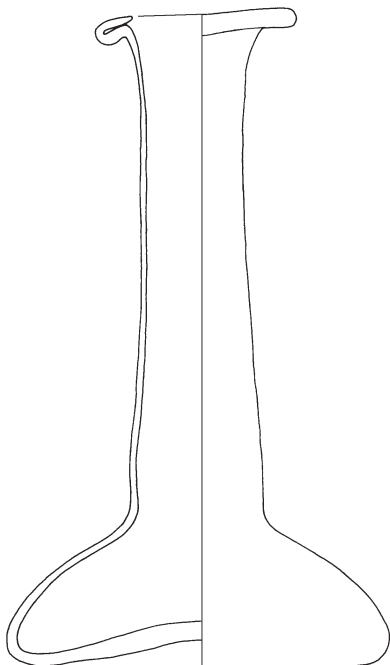

7

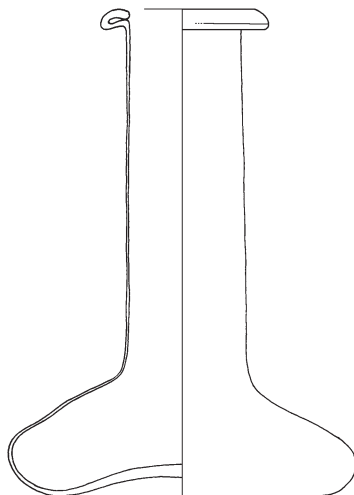

8

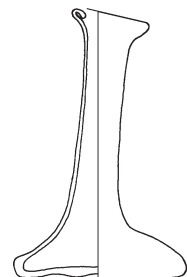

9

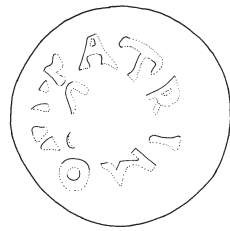
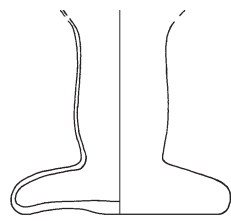
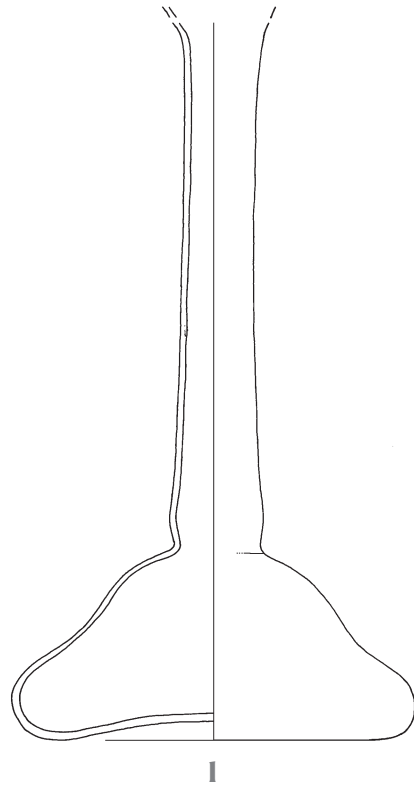

2

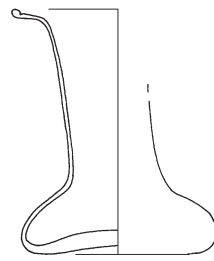

3

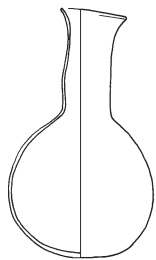

4

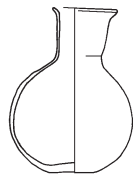

5

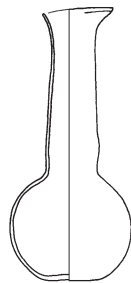

6

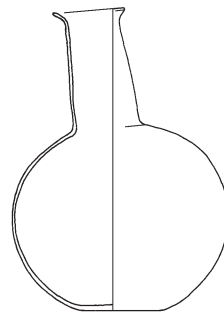

7

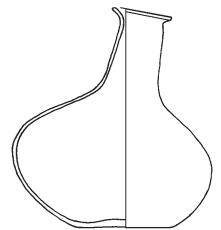

8

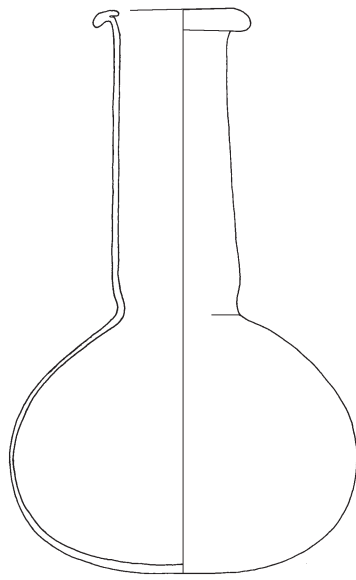

1

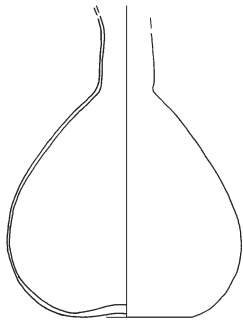

2

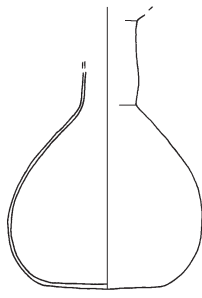

3

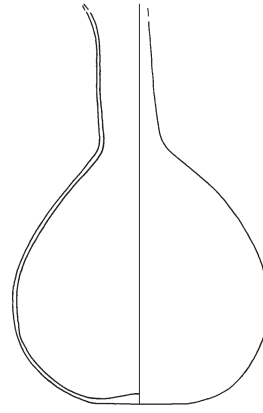

4

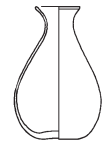

5

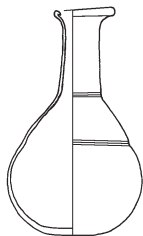

6

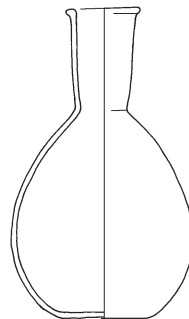

7



1

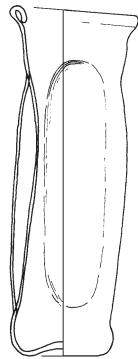

2

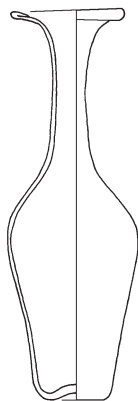

3